

TCT SAW BLADE FOR WOOD

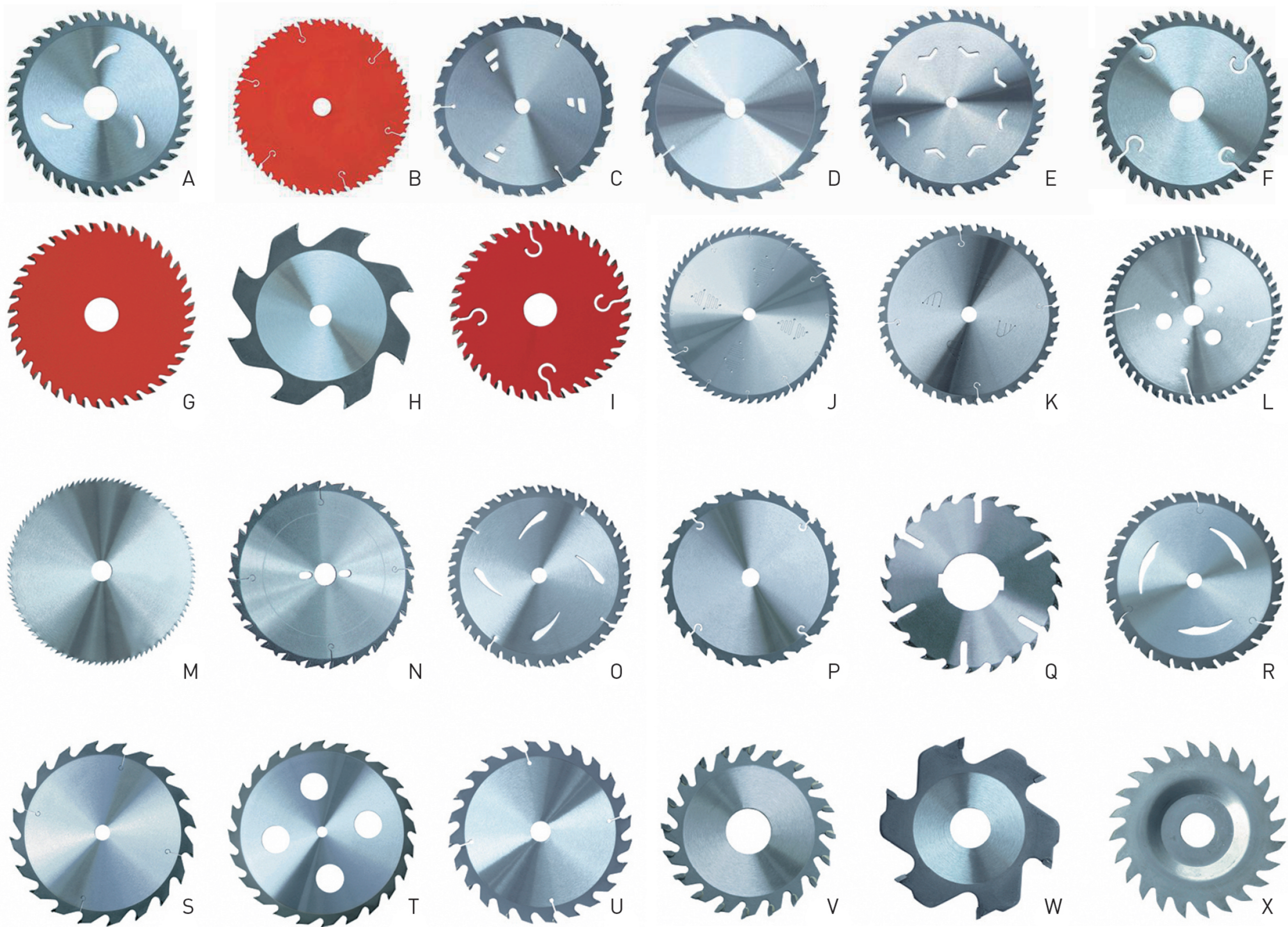

Art No.	Outer Diamoten		Body Thickness	Hole Diameter (MM)	Kerf	Teeth Number
	Metric (MM)	Inch				
ECTCT1001	85	3.3"	1.1	20	1.8	18T/20T/24T/30T/36/48T
ECTCT1002	89	3.5"	1.1	20	1.8	
ECTCT1003	105	4"	1.2/1.4	22.23	2.0/2.2	18T/20T/24T/30T/36T/40/48T
ECTCT1004	110	4.3"	1.2/1.4	22.23	2.0/2.2	
ECTCT1005	125	5"	1.2/1.4	22.23	2.0/2.2	18T/20T/24T/30T/36T/40T/48/60T
ECTCT1006	136	5.4"	1.4/1.6	22.23	2.2/2.4	
ECTCT1007	140	5.5"	1.4/1.6	22.23	2.2/2.4	18T/20T/24T/30T/36T/40T/48/60T
ECTCT1008	150	6"	1.4/1.6	22.23	2.2/2.4	
ECTCT1009	160	6.3"	1.4/1.6	25.4	2.2/2.4	18T/20T/24T/30T/36T/40T/48T/50T/60T/8DT
ECTCT1010	180	7"	1.4/1.6	25.4	2.2/2.4	
ECTCT1011	185	7.3"	1.4/1.6	25.4	2.2/2.4	18T/20T/24T/30T/36T/40T/48T/50T/60T/8DT
ECTCT1012	190	7.5"	1.4/1.6	25.4	2.2/2.4	
ECTCT1013	200	8"	1.4/1.6	25.4	2.2/2.4	18T/20T/24T/30T/36T/40T/48T/50T/60T/8DT
ECTCT1014	210	8.3"	1.4/1.6	25.4	2.2/2.4	
ECTCT1015	216	8.5"	1.4/1.6	25.4	2.2/2.4	18T/20T/24T/30T/36T/40T/48T/50T/60T/80T/90/96/100/120T
ECTCT1016	230	9"	1.6/1.8	22.23/25.4/30	2.4/2.6	
ECTCT1017	250	10"	1.8/2.0	22.23/25.4/30	2.8/3.0	18T/20T/24T/30T/36T/40T/48T/50T/60T/80T/90/96/100/120T
ECTCT1018	300	12"	2.0/2.2	25.4/30	3.0/3.2	
ECTCT1019	350	14"	2.2/2.4	25.4/30	3.2/3.4	18T/20T/24T/30T/36T/40T/48T/50T/60T/80T/90/96/100/120T
ECTCT1020	400	16"	2.4/2.6	25.4/30/50	3.4/3.6	
ECTCT1021	450	18"	2.4/2.6	25.4/30/50	3.4/3.6	18T/20T/24T/30T/36T/40T/48T/50T/60T/80T/90/96/100/120T
ECTCT1022	500	20"	2.8/3.0	25.4/30/50	3.8/4.0	
ECTCT1023	600	24"	3.0/3.2	25.4/30/50	4.0/4.2	18T/20T/24T/30T/36T/40T/48T/50T/60T/80T/90/96/100/120T

TCT SAW BLADE FOR WOOD

SUPERTHIN CORDLESS BATTERY
SAW BLADE FOR WOOD

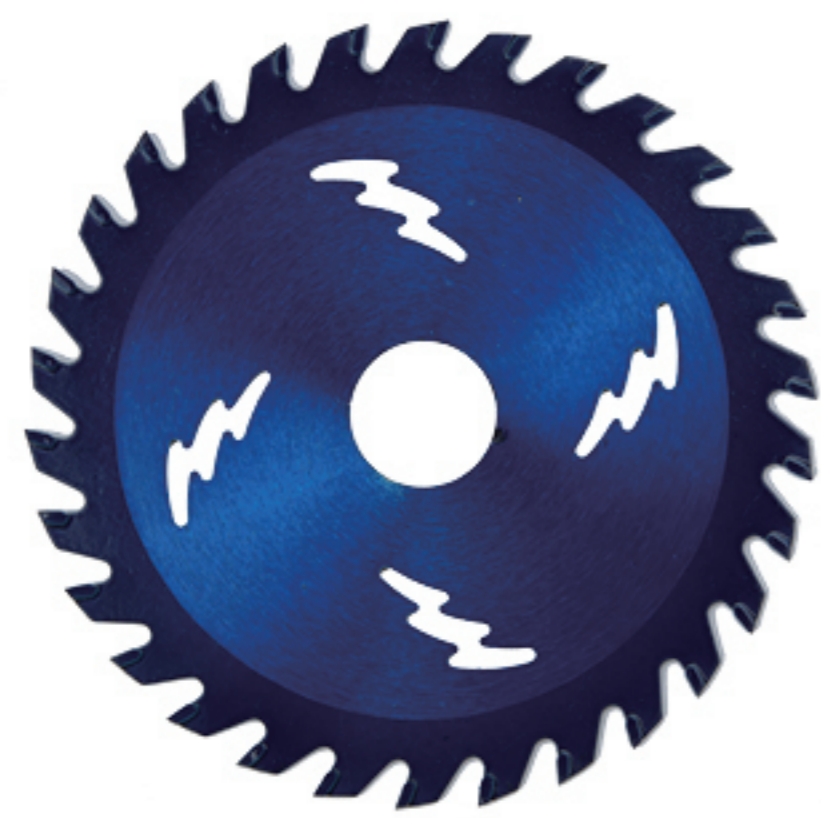

Art No.	Outer diameter		Body thickness	Hole Diameter	Kerf	Teeth Number
	Metric(MM)	Inch				
ECTCT2001	110	4.3"	1.0/1.2	10/16/20	1.6/2.0	16/18/24/30/40
ECTCT2002	125	5"	1.0/1.2	20	1.8/2.0/2.2	
ECTCT2003	140	5.5"	1.0/1.2/1.4	20	1.8/2.0/2.2	
ECTCT2004	150	6"	1.0/1.2/1.4	20	1.8/2.0/2.2	
ECTCT2005	165	6.5"	1.0/1.2/1.4	20	1.8/2.0/2.2	

TCT SAW BLADE FOR SLOTTING

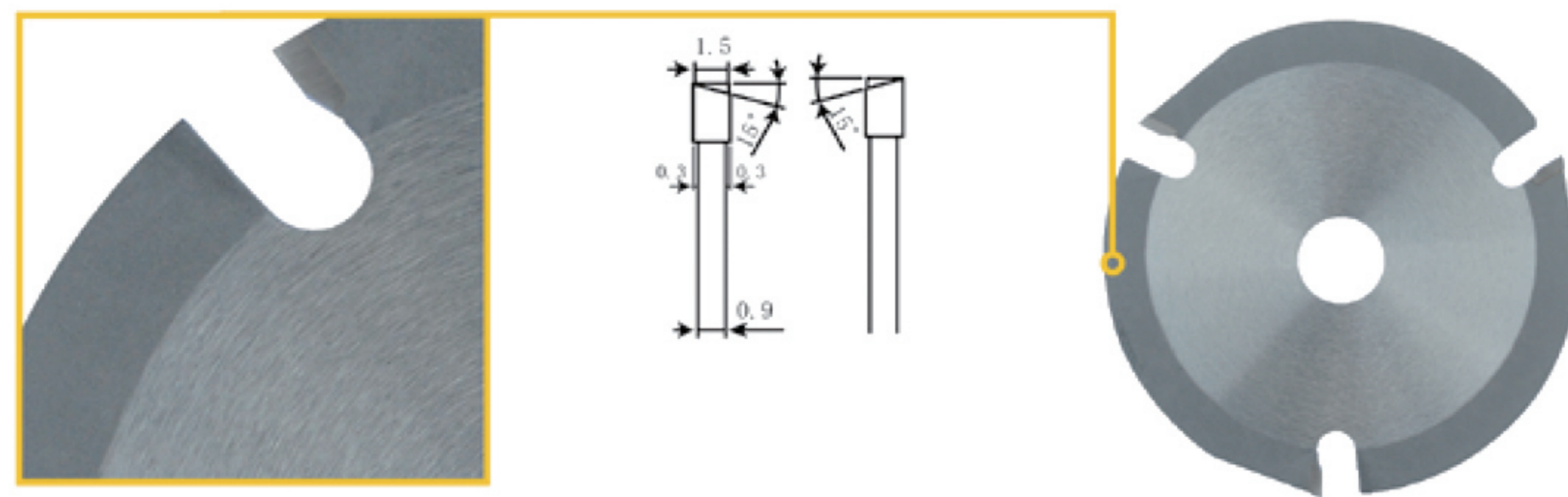

Art No.	Outer diameter		Body thickness	Hole Diameter	Kerf	Teeth Number
	Metric(MM)	Inch				
ECTCT2006	180	7"	1.4/1.6	25.4	2.2/2.4	18T/24T/30T/36T/ 40T/48T/60T/80T/ 100T/120T
ECTCT2007	185	7.3"	1.4/1.6	25.4	2.2/2.4	
ECTCT2008	190	7.5"	1.4/1.6	25.4	2.2/2.4	
ECTCT2009	200	8"	1.4/1.6	25.4	2.2/2.4	
ECTCT2010	210	8.3"	1.4/1.6	25.4	2.2/2.4	
ECTCT2011	230	9"	1.4/1.6	25.4	2.2/2.4	
ECTCT2012	250	10"	1.4/1.8	25.4	2.4/2.6	24T/30T/36T/40T /48T/80T/80T/100 T/120T
ECTCT2013	300	12"	1.8/2.0	30	2.8/3.0	
ECTCT2014	350	14"	2.0/2.2	30	3.0/3.2	
ECTCT2015	400	16"	2.2/2.4	30	3.2/3.4	
ECTCT2016	450	16"	2.4/2.8	30	3.4/3.6	

TCT SAW BLADE FOR MDF



Art No.	Outer Diameter		Body Thickness	Hole Diameter	Kerf	Teeth Number
	Metric (MM)	Inch				
ECTCT3001	200	8"	3.2/2.2	30	4.2/3.2	66
ECTCT3002	250	10"	3.2/2.2	30	4.2/3.2	80
ECTCT3003	300	12"	3.2/2.2	30	4.2/3.2	96
ECTCT3004	350	14"	3.2/2.5	35	4.2/3.5	108
ECTCT3005	140	5/2"	1.4	20	2.2	30T
ECTCT3006	140	5/2"	1.4	20	2.2	40T



Art No.	Outer Diameter		Body Thickness	Hole Diameter	Kerf	Teeth Number
	Metric (MM)	Inch				
ECTCT3007	110	4-1/4"	2.0/1.4	16	3.0/2.4	40-40
ECTCT3008	150	6"	2.2/1.6	20	3.2/2.6	30
ECTCT3009	180	7"	3.0/1.6	20	4/2.6	36-32
ECTCT3010	250	10"	2.8/2.2	25.4	3.8/3.2	80
ECTCT3011	300	12"	3.0/2.5	25.6/32	4.0/3.5	80-84
ECTCT3012	350	14"	3.0/2.5	32	4.0/3.5	80-84
ECTCT3013	400	16"	3.0/2.5	30	4.0/3.5	100

TCT SAW BLADE FOR ALUMINUM

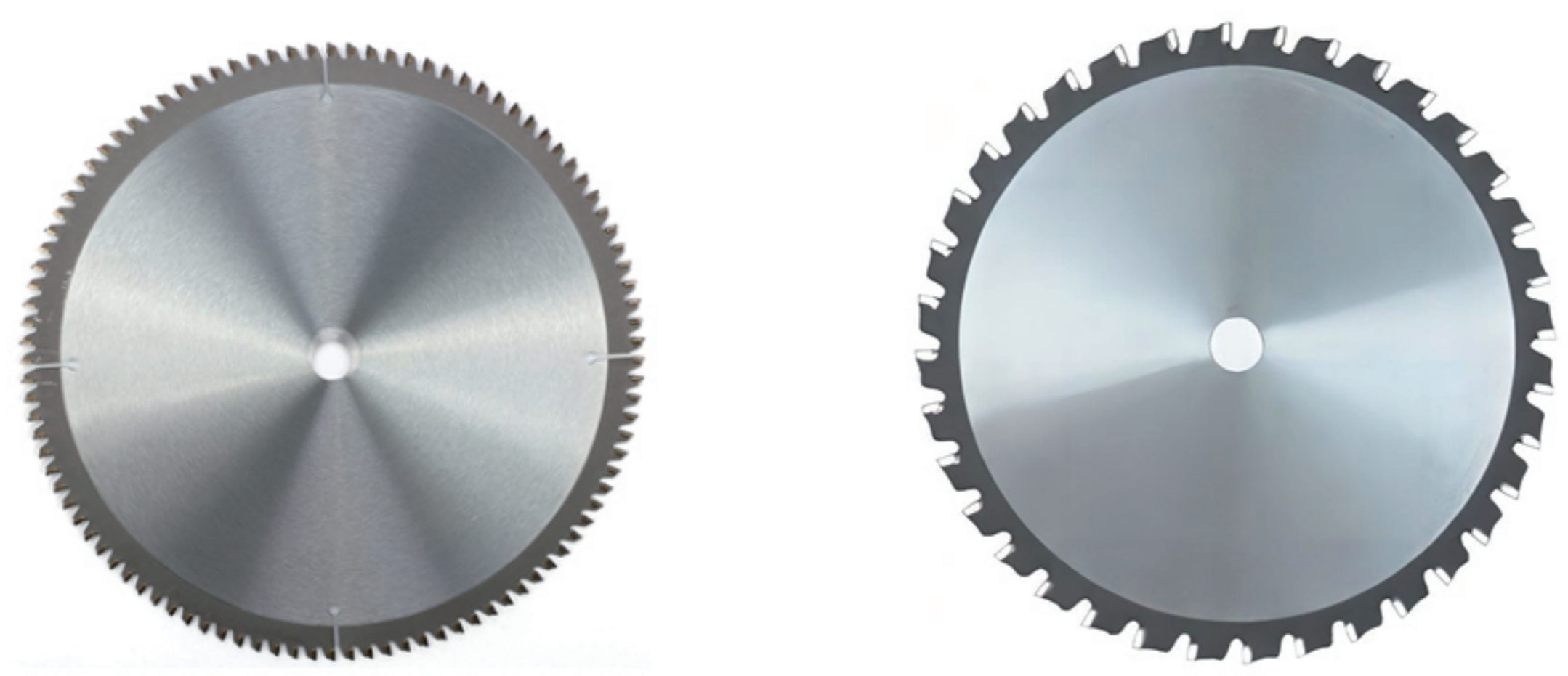

Art No.	Outer Diameter		Body Thickness	Hole Diameter	Kerf	Teeth Number
	Metric (MM)	Inch				
ECTCT4001	180	7"	1.4/1.6	25.4	2.2/2.4	18T/24T/30T/36T/ 40T/48T/60T/80T /100T/120T
ECTCT4002	185	7.3"	1.4/1.6	25.4	2.2/2.4	
ECTCT4003	190	7.5"	1.4/1.6	25.4	2.2/2.4	
ECTCT4004	200	8"	1.4/1.6	25.4	2.2/2.4	
ECTCT4005	210	8.3"	1.4/1.6	25.4	2.2/2.4	
ECTCT4006	230	9"	1.6/1.8	25.4	2.4/2.6	
ECTCT4007	250	10"	1.8/2.0	25.4	2.8/3.0	24T/30T/36T/40T/48T/ 60T/80T/100T/120T
ECTCT4008	300	12"	2.0/2.2	30	3.0/3.2	
ECTCT4009	350	14"	2.2/2.4	30	3.2/3.4	
ECTCT4010	400	16"	2.4/2.6	30	3.4/3.6	
ECTCT4011	450	18"	2.4/2.6	30	3.4/3.6	

*Other sizes are available

TCT SAW BLADE FOR METAL



Art No.	Outer Diameter		Body Thickness	Hole Diameter (MM)	Kerf	Teeth Number
	Metric (MM)	Inch				
ECTCT5001	110	4.3"	1.2/1.4	20	2.0/2.2	20T/24T/30T/ 36T/40T
ECTCT5002	115	4.5"	1.2/1.4	20	2.0/2.2	
ECTCT5003	125	5"	1.2/1.4	20	2.0/2.2	
ECTCT5004	130	5.1"	1.4/1.6	20	2.2/2.4	
ECTCT5005	136	5.4"	1.4/1.6	20	2.2/2.4	
ECTCT5006	150	6"	1.4/1.6	20	2.2/2.4	
ECTCT5007	180	7"	1.4/1.6	25.4	2.2/2.4	24T/30T/36T/40T/ 48T/60T/80T/
ECTCT5008	190	7.5"	1.4/1.6	25.4	2.2/2.4	
ECTCT5009	230	9"	1.6/1.8	25.4	2.4/2.6	
ECTCT5010	250	10"	1.8/2.0	30	2.8/3.0	
ECTCT5011	300	12"	2.0/2.2	30	3.0/3.2	24T/30T/36T/40T/48T/ 60T/80T/100T
ECTCT5012	355	14"	2.2/2.4	30	3.2/3.4	

TCT SAW BLADE FOR GRASS

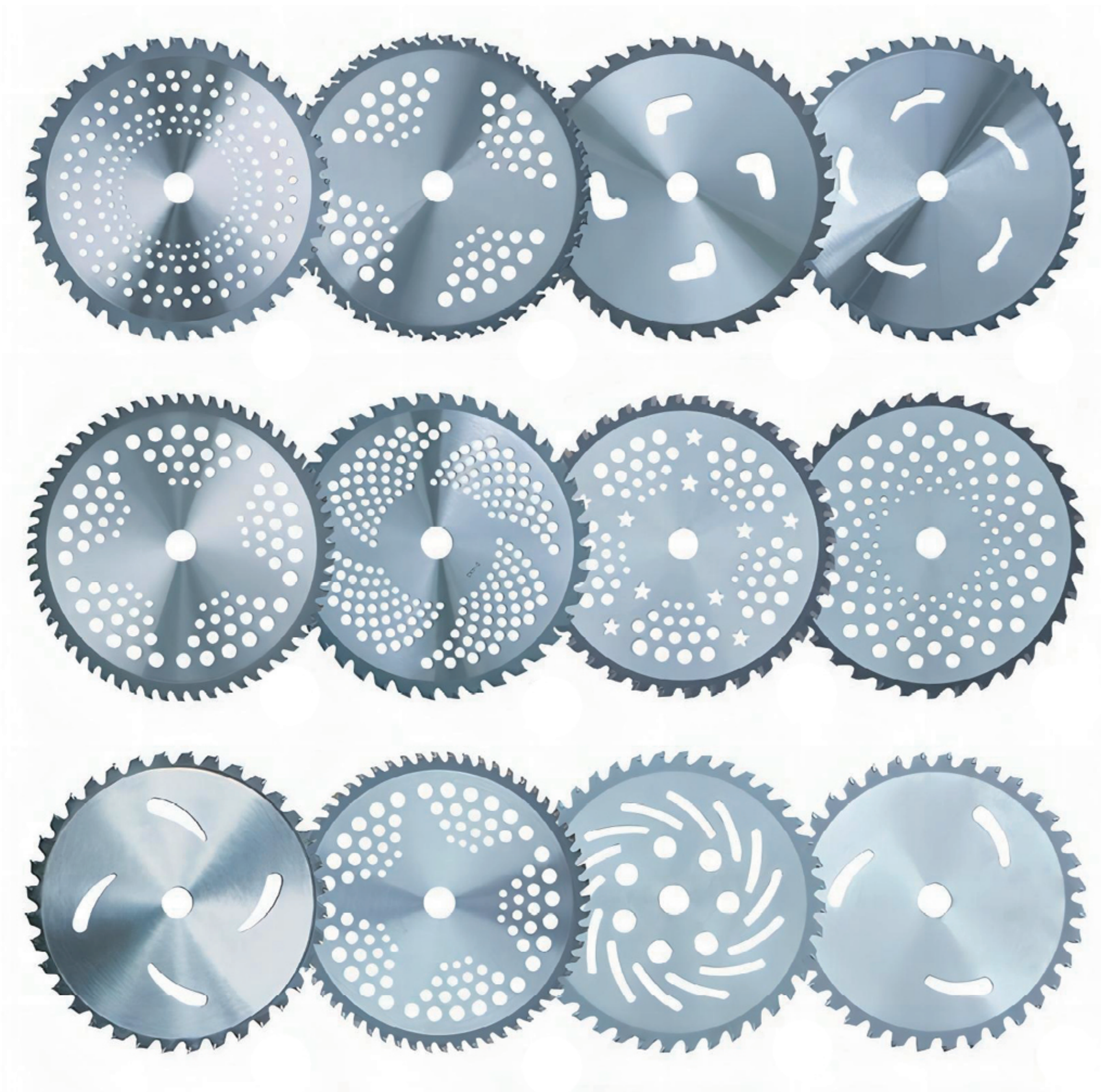

Art No.	Outer Diameter		Body Thickness	Hole Diameter	Kerf	Teeth Number
	Metric (MM)	Inch				
ECTCT6001	230	9"	1.3	25.4	2	36
ECTCT6002	230	9"	1.3	25.4	2	40
ECTCT6003	255	10"	1.3	25.4	2	36
ECTCT6004	255	10"	1.3	25.4	2	40

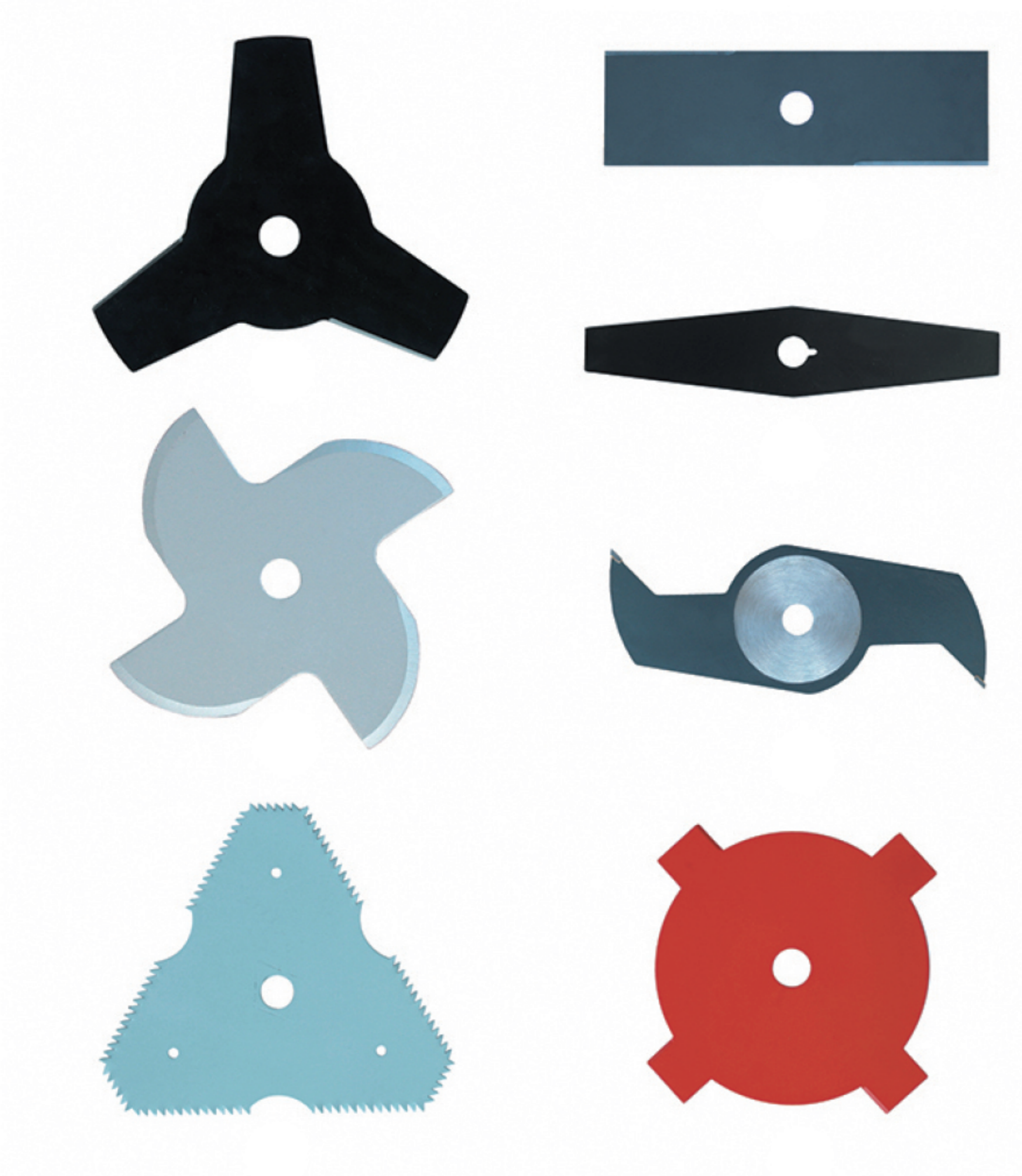

Art No.	Outer Diameter		Body Thickness	Hole Diameter	Teeth Number
	Metric (MM)	Inch			
ECTCT6005	185	7"	1.6	25.4	2T
ECTCT6006	255	10"	1.6/1.8	25.4	3T
ECTCT6007	305	12"	1.6/1.8/2.0/3.0	25.4	4T

*Other sizes are available



DIAMOND SAW BLADE - SUPERTHIN

© SUPER THIN TILE
DIAMOND SAW BLADE

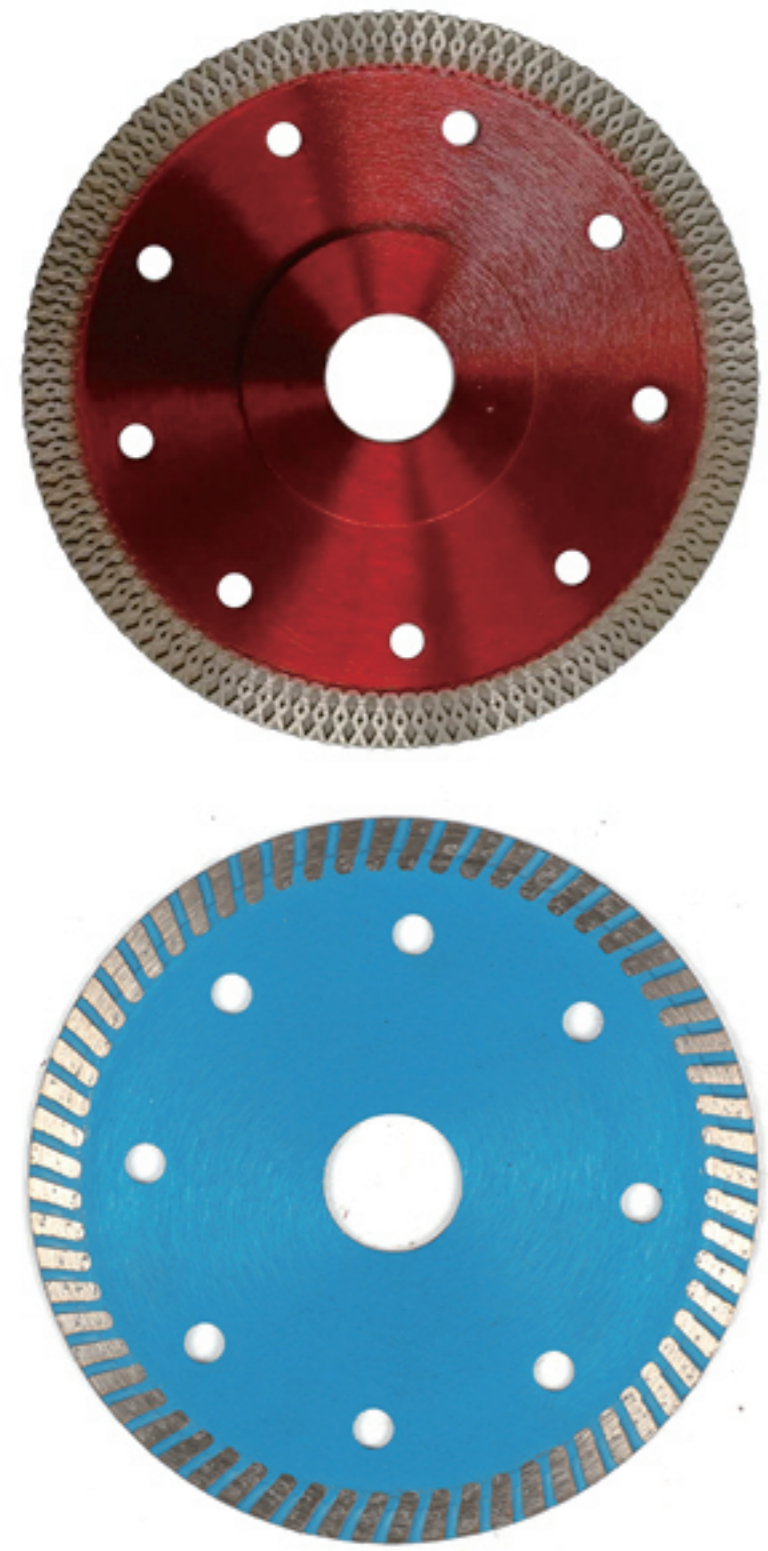

Outer Diameter		Hole Diameter [MM]	Segment Dimension
Metric[MM]	Inch		
50	2"	15.88	1.2x10
80	3"	15.88	1.2x10
105	4"	16/20/22.23	1.2x10
110	4.3"	16/20/22.23	1.2x10
115	4.5"	20/22.23	1.2x10
125	5"	20/22.23	1.4x10
150	6"	22.23/25.4/30	1.6x10
180	7"	22.23/25.4/30	1.6x10
230	8"	22.23/25.4/30/50	1.6x10
250	9"	22.23/25.4/30/50	1.8x10
300	10"	22.23/25.4/30/50	2.0x10
350	12"	22.23/25.4/30/50	2.2x10
400	14"	22.23/25.4/30/50	2.4x10
400	16"	22.23/25.4/30/50	2.8x10

DIAMOND SAW BLADE - SEGMENT

© SEGMENTED DIAMOND SAW
BLADE

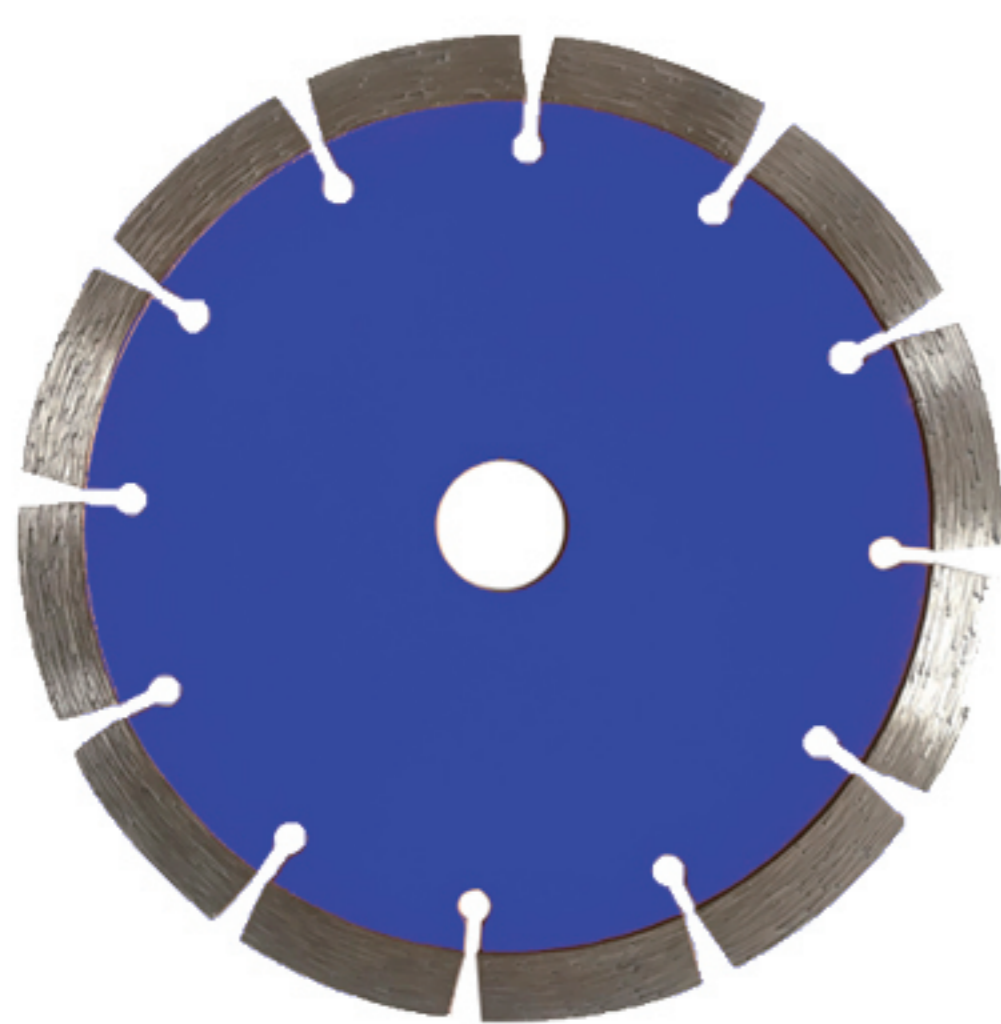

Outer Diameter		Hole Diameter [MM]	Segment Dimension
Metric(MM)	Inch		
115	4.5"	20/22.23	1.9x7.0x38.3
125	5"	20/22.23	2.0x7.0x37.5
150	6"	20/22.23	2.0x7.0x37.5
180	7"	22.23/25.4/30	2.2x7.0x35
200	8"	22.23/25.4/30	2.4x7.0x34.4
230	9"	22.23/25.4/30/50	2.4x7.2x34.4
250	10"	22.23/25.4/30/50	2.8x7.5x37
300	12"	22.23/25.4/30/50	3.2x7.5x35
350	14"	22.23/25.4/30/50	3.2x7.5x40
400	16"	22.23/25.4/30/50	3.4x7.5x40

© "U"SHARP SEGMENTED
DIAMOND SAW BLADE

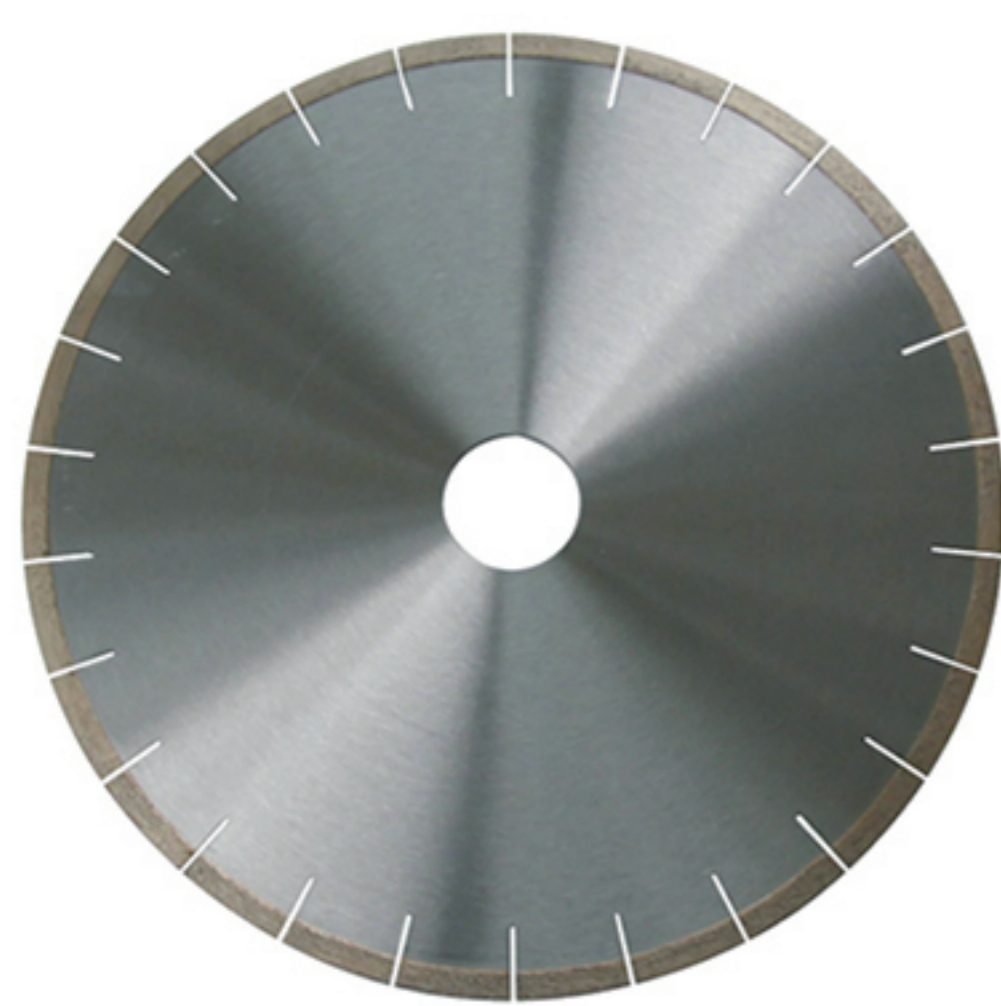

Outer Diameter		Hole Diameter [MM]	Segment Dimension
Metric(MM)	Inch		
105	4"	16/20/22.23	1.2x10
110	4.3"	16/20/22.23	1.2x10
115	4.5"	20/22.23	1.2x10
125	5"	20/22.23	1.4x10
150	6"	20/22.23	1.4x10
180	7"	22.23/25.4/30	1.6x10
200	8"	22.23/25.4/30	1.8x10
230	9"	22.23/25.4/30/50	1.8x10
250	10"	22.23/25.4/30/50	2.2x10
300	12"	22.23/25.4/30/50	2.2x10
350	14"	22.23/25.4/30/50	2.4x10
400	16"	22.23/25.4/30/50	2.8x10

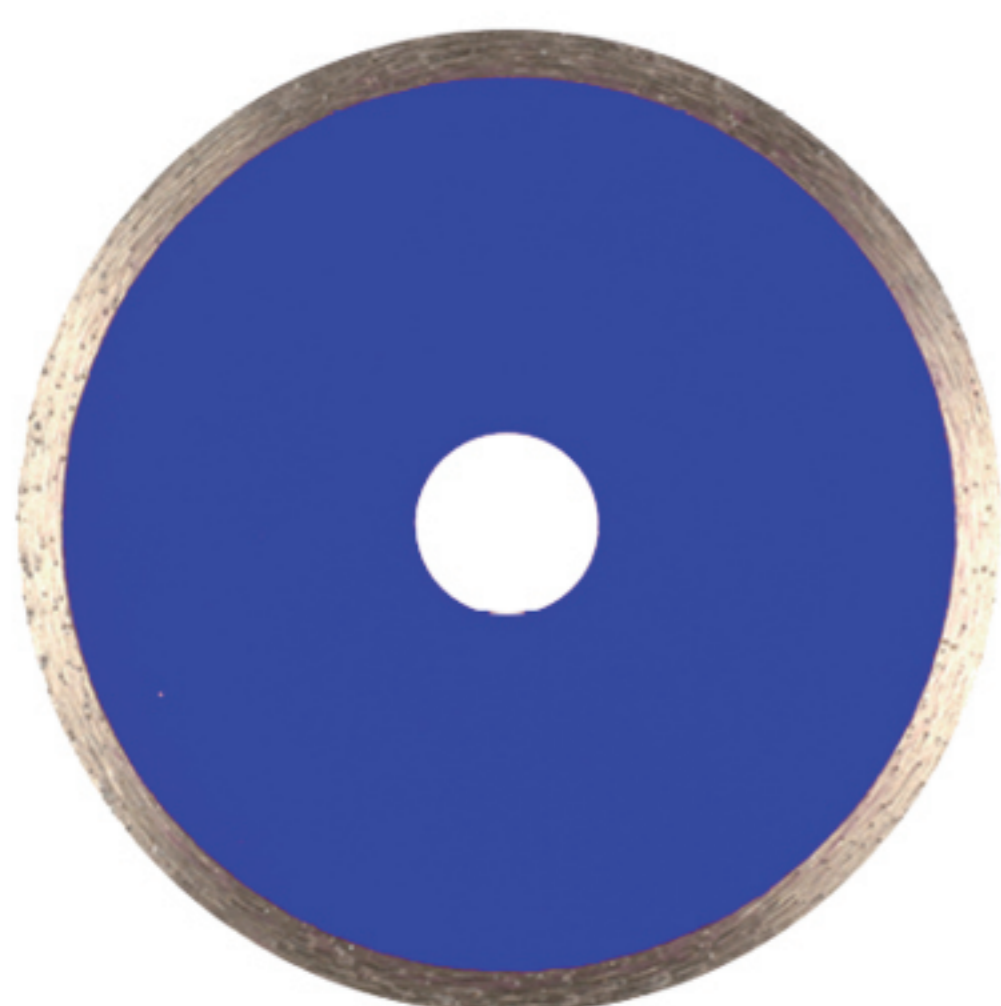

© CONTINUOUS RIM SAW
BLADE (COLD PRESSED)

Outer Diameter		Hole Diameter [MM]	Segment Dimension
Metric(MM)	Inch		
50	2"	15.88	1.6x7.0
80	3"	15.88	1.6x7.0
105	4"	16/20/22.23	1.8x7.0
110	4.3"	16/20/22.23	1.8x7.0
115	4.5"	20/22.23	1.9x7.0
125	5"	20/22.23	2.0x7.0
150	6"	20/22.23	2.0x7.0
180	7"	22.23/25.4/30	2.2x7.0
200	8"	22.23/25.4/30	2.4x7.0
230	9"	22.23/25.4/30/50	2.4x7.2
250	10"	22.23/25.4/30/50	2.8x7.5
300	12"	22.23/25.4/30/50	3.2x7.5
350	14"	22.23/25.4/30/50	3.2x7.5
400	16"	22.23/25.4/30/50	3.4x7.5

*Other sizes are available

DIAMOND SAW BLADE - CONTINUOUS

© CONTINUOUS RIM SAW
BLADE (HOT PRESSED)

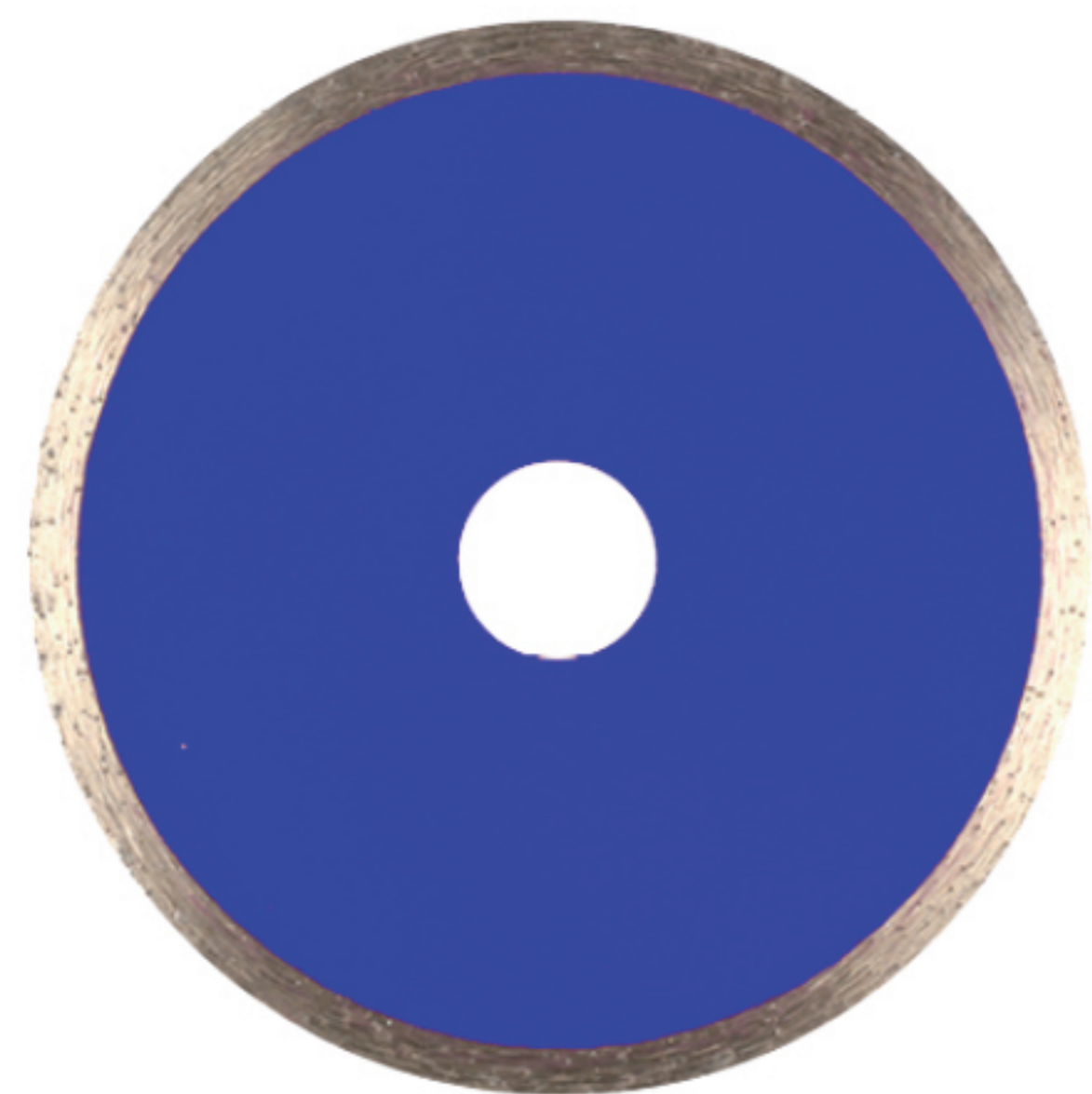

Outer Diameter		Hole Diameter [MM]	Segment Dimension
Metric (MM)	Inch		
105	4"	16/20/22.23	1.8x7.0
110	4.3"	16/20/22.23	1.9x7.0
115	4.5"	20/22.23	1.9x7.0
125	5"	20/22.23	2.0x7.0
150	6"	20/22.23	2.0x7.0
180	7"	22.23/25.4/30	2.2x7.0
200	8"	22.23/25.4/30	2.4x7.0
230	9"	22.23/25.4/30/50	2.4x7.2
250	10"	22.23/25.4/30/50	2.8x7.5
300	12"	22.23/25.4/30/50	3.2x7.5
350	14"	22.23/25.4/30/50	3.2x7.5
400	16"	22.23/25.4/30/50	3.4x7.5
350	14"	22.23/25.4/30/50	3.2x7.5
400	16"	22.23/25.4/30/50	3.4x7.5

*Other sizes are available

DIAMOND SAW BLADE - TURBO

© TURBO SAW BIADDE

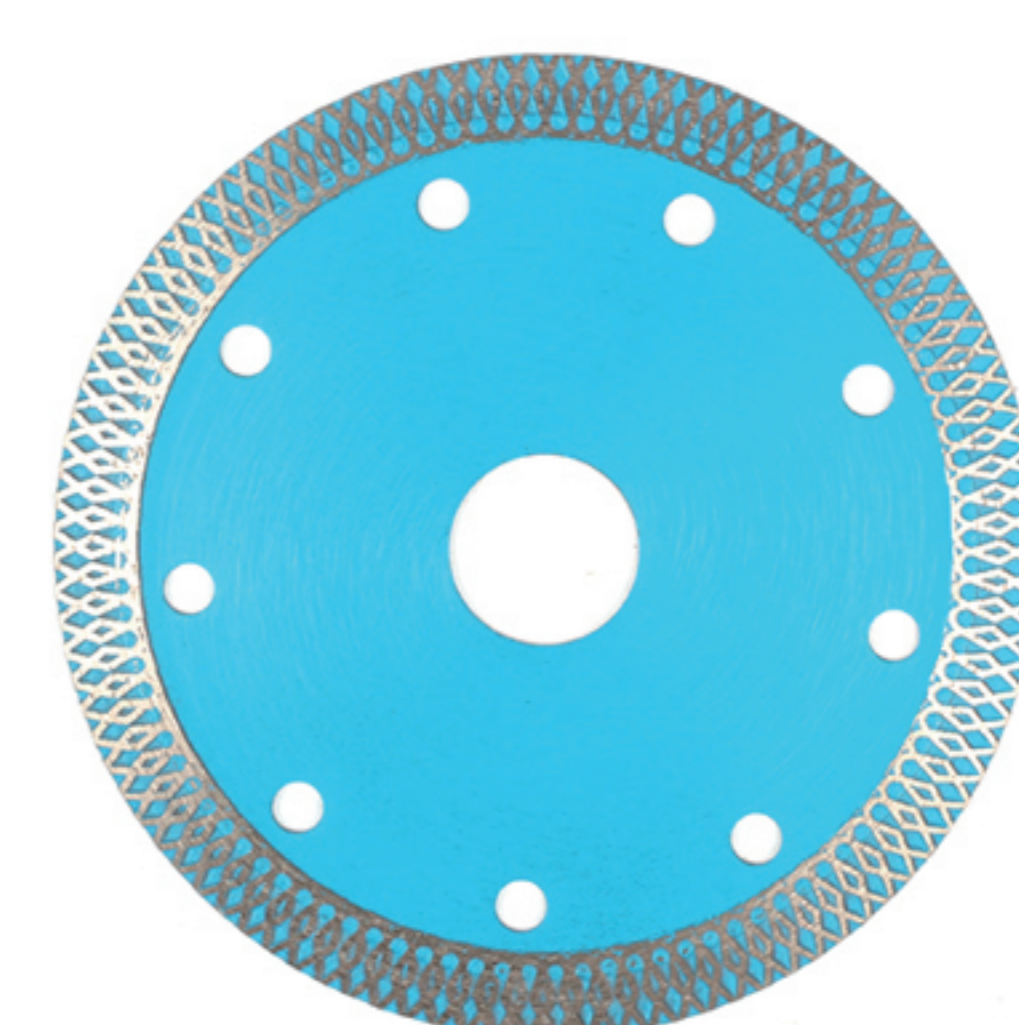
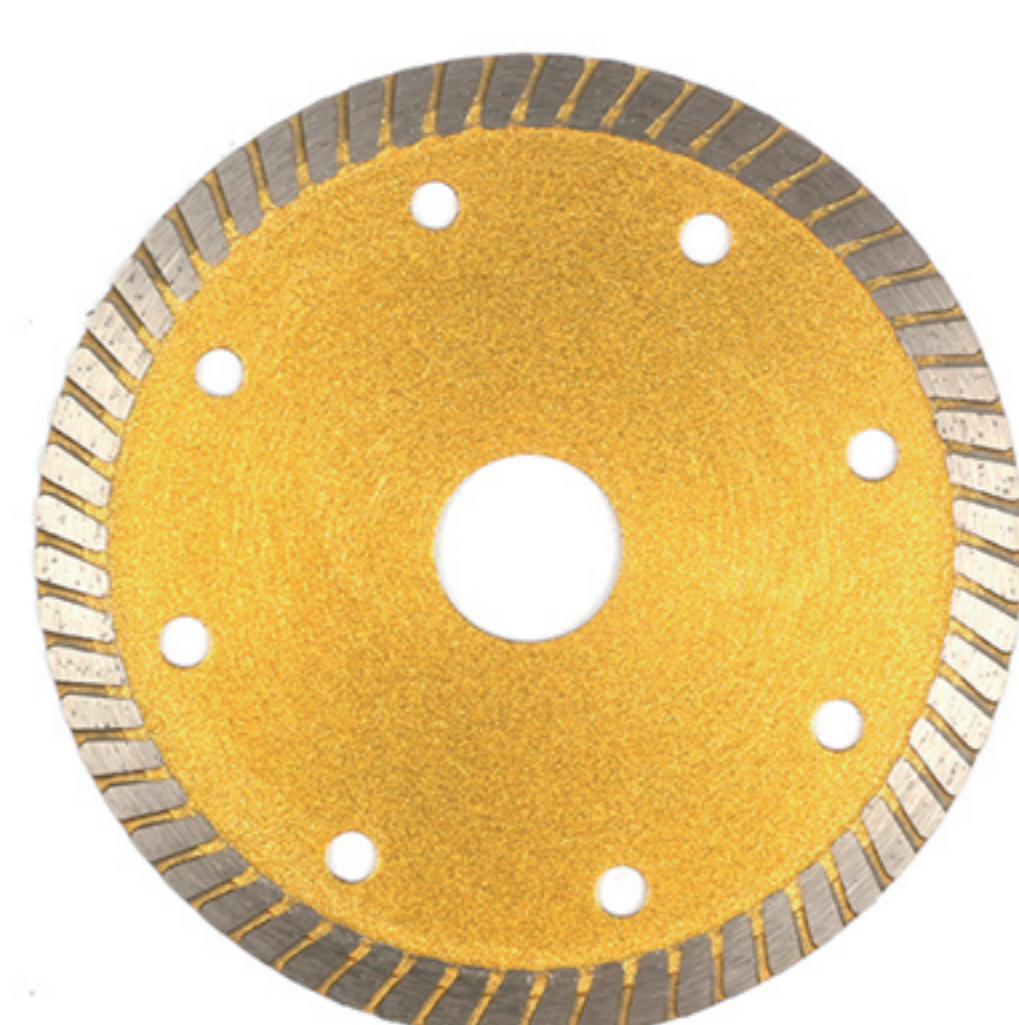
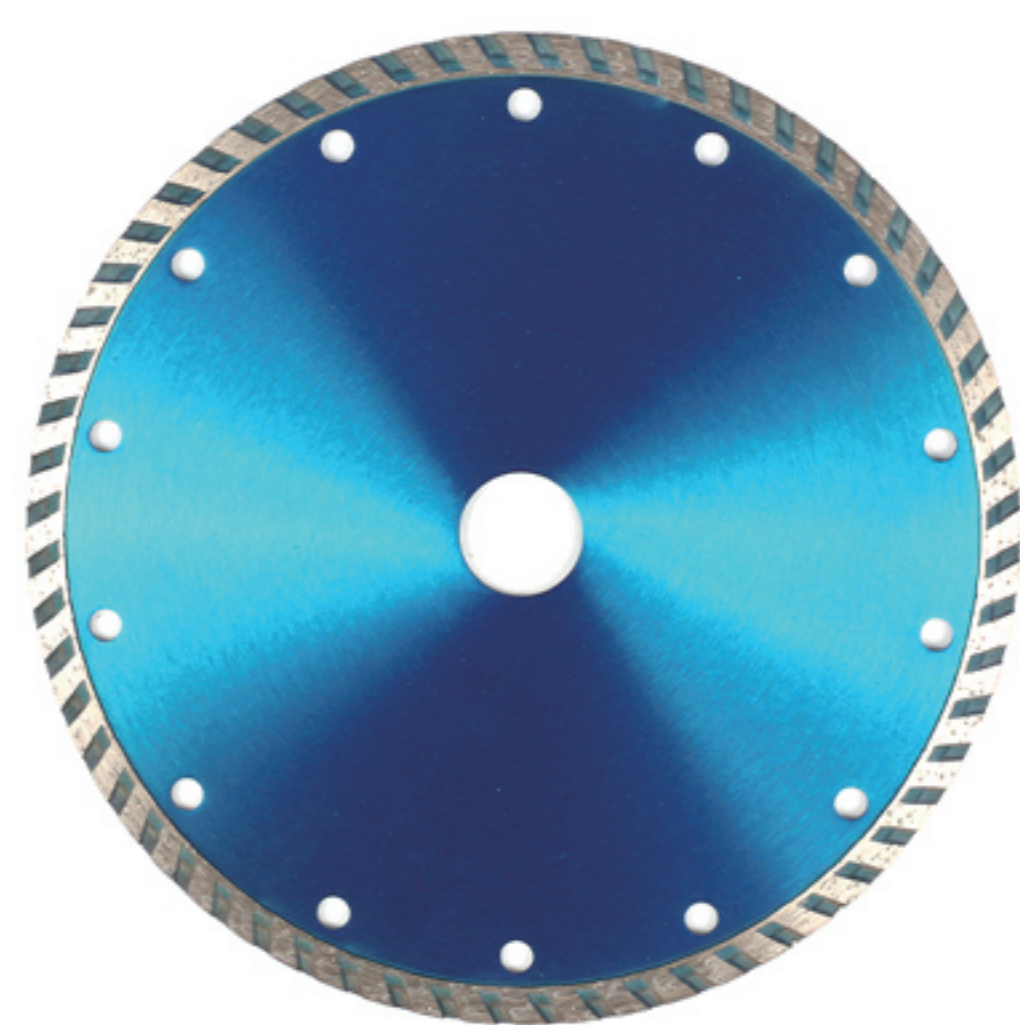
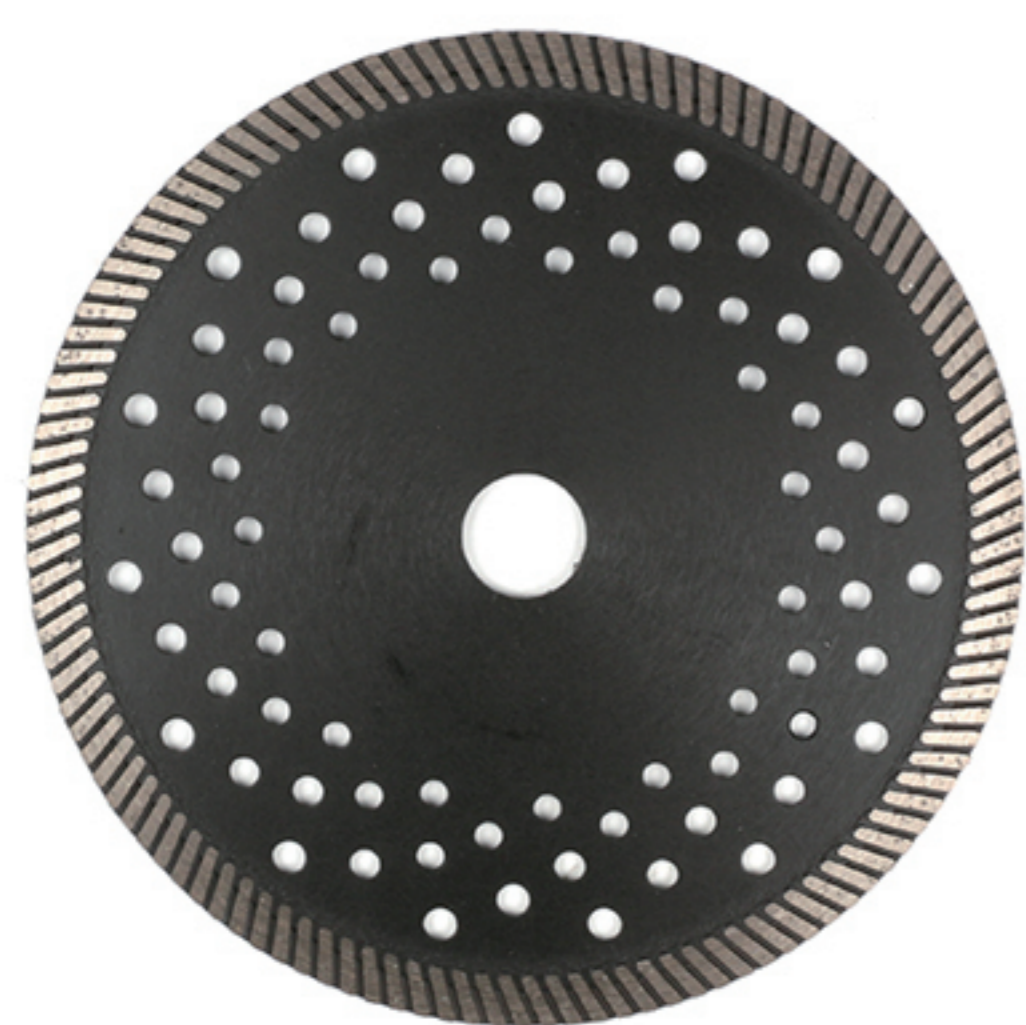

Outer Diameter		Hole Diameter	Segment Dimension
Metric(MM)	Inch		
105	4"	16/20/22.23	2.0x7.0
110	4.3"	16/20/22.23	2.0x7.0
115	4.5"	20/22.23	2.0x7.0
125	5"	20/22.23	2.2x7.0
150	6"	20/22.23	2.2x7.0
180	7"	22.23/25.4/30	2.4x7.0
200	8"	22.23/25.4/30	2.6x7.2
230	9"	22.23/25.4/30/50	2.8x7.5
250	10"	22.23/25.4/30/50	3.0x7.5
300	12"	22.23/25.4/30/50	3.2x7.5
350	14"	22.23/25.4/30/50	3.4x7.5

DIAMOND SAW BLADE - TURBO

© SEGMENT TURBO DIAMOND SAW BLADE

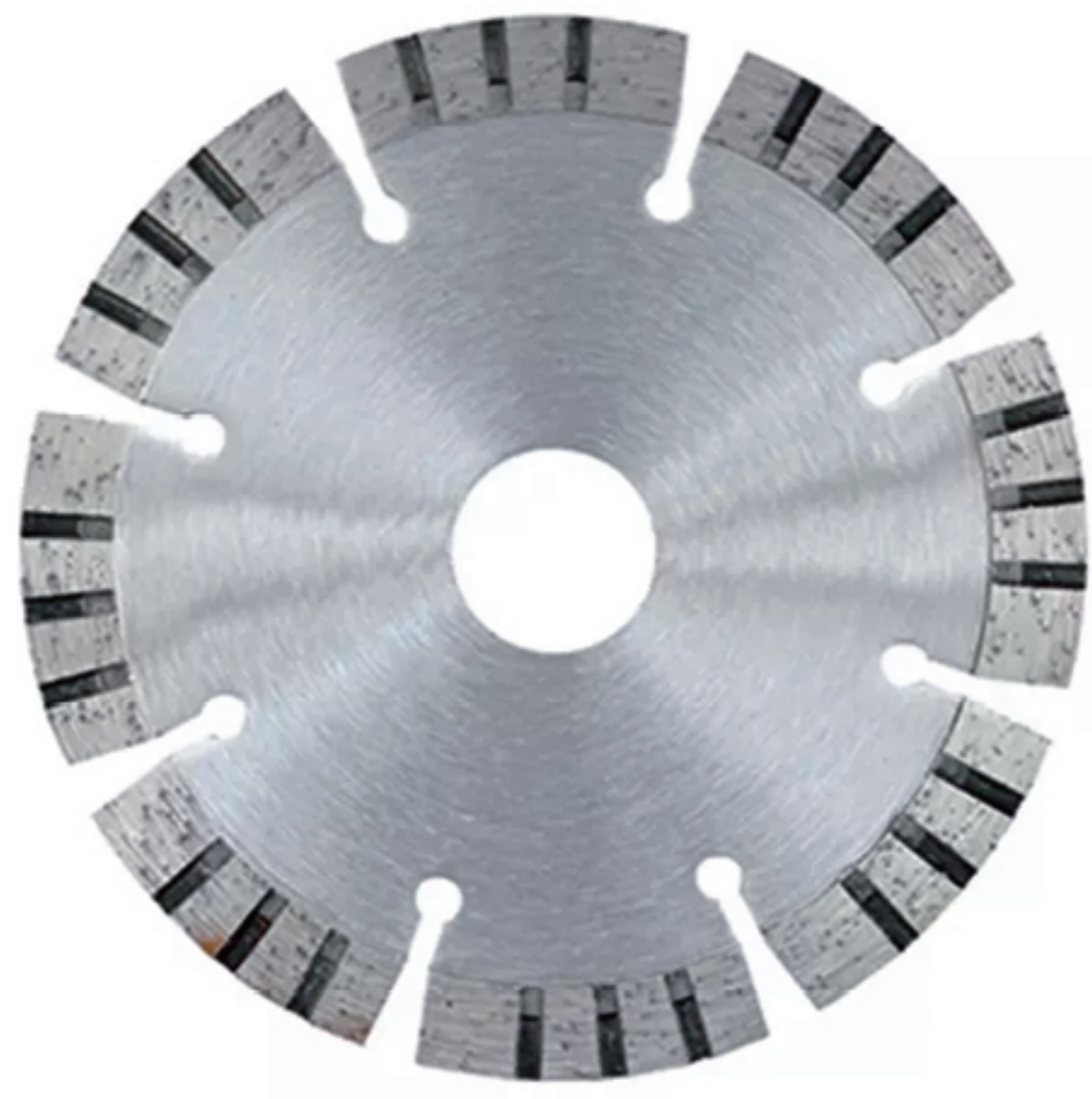

Outer Diameter		Hole Diameter [MM]	Segment Dimension
Metric (MM)	Inch		
105	4"	16/20/22.23	2.0x10x35
110	4.3"	16/20/22.23	2.0x10x32.3
115	4.5"	20/22.23	2.0x10x38.3
125	5"	20/22.23	2.2x10x37.5
150	6"	20/22.23	2.2x10x33.5
180	7"	22.23/25.4/30	2.4x10x35
200	8"	22.23/25.4/30	2.6x10x34.4
230	9"	22.23/25.4/30/50	2.6x10x34.4
250	10"	22.23/25.4/30/50	3.0x10x37
300	12"	22.23/25.4/30/50	3.0x10x35
350	14"	22.23/25.4/30/50	3.2x10x40
400	16"	22.23/25.4/30/50	3.4x10x40

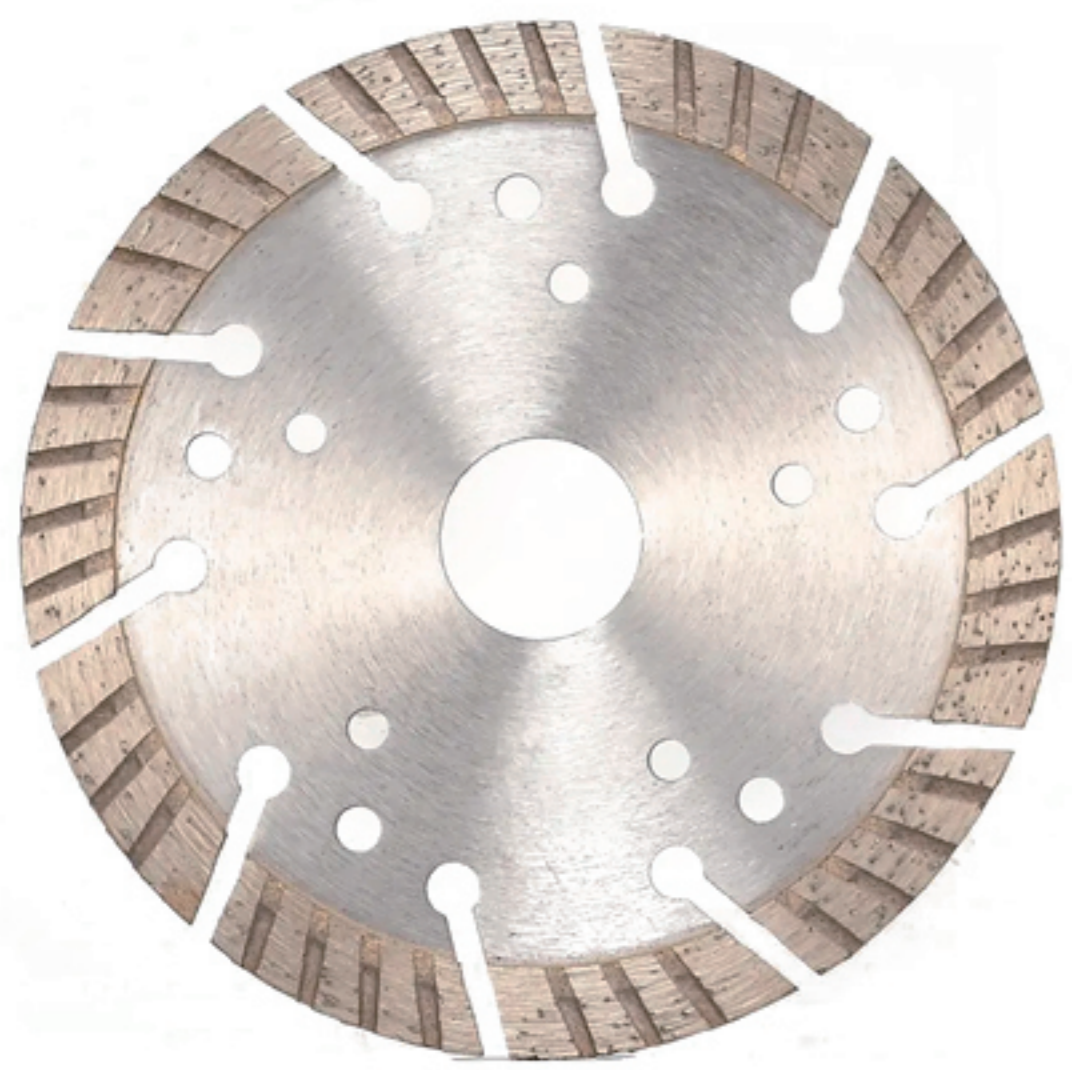

© SEGMENT TURBO DIAMOND SAW

Outer Diameter		Hole Diameter [MM]	Segment Dimension
Metric (MM)	Inch		
105	4"	16/20/22.23	2.0x10x35
110	4.3"	16/20/22.23	2.0x10x32.3
115	4.5"	20/22.23	2.0x10x38.3
125	5"	20/22.23	2.2x10x37.5
150	6"	20/22.23	2.2x10x33.5
180	7"	22.23/25.4/30	2.4x10x35
200	8"	22.23/25.4/30	2.6x10x34.4
230	9"	22.23/25.4/30/50	2.6x10x34.4
250	10"	22.23/25.4/30/50	3.0x10x37
300	12"	22.23/25.4/30/50	3.0x10x35
350	14"	22.23/25.4/30/50	3.2x10x40
400	16"	22.23/25.4/30/50	3.4x10x40



*Other sizes are available

DIAMOND SAW BLADE - TURBO WAVE

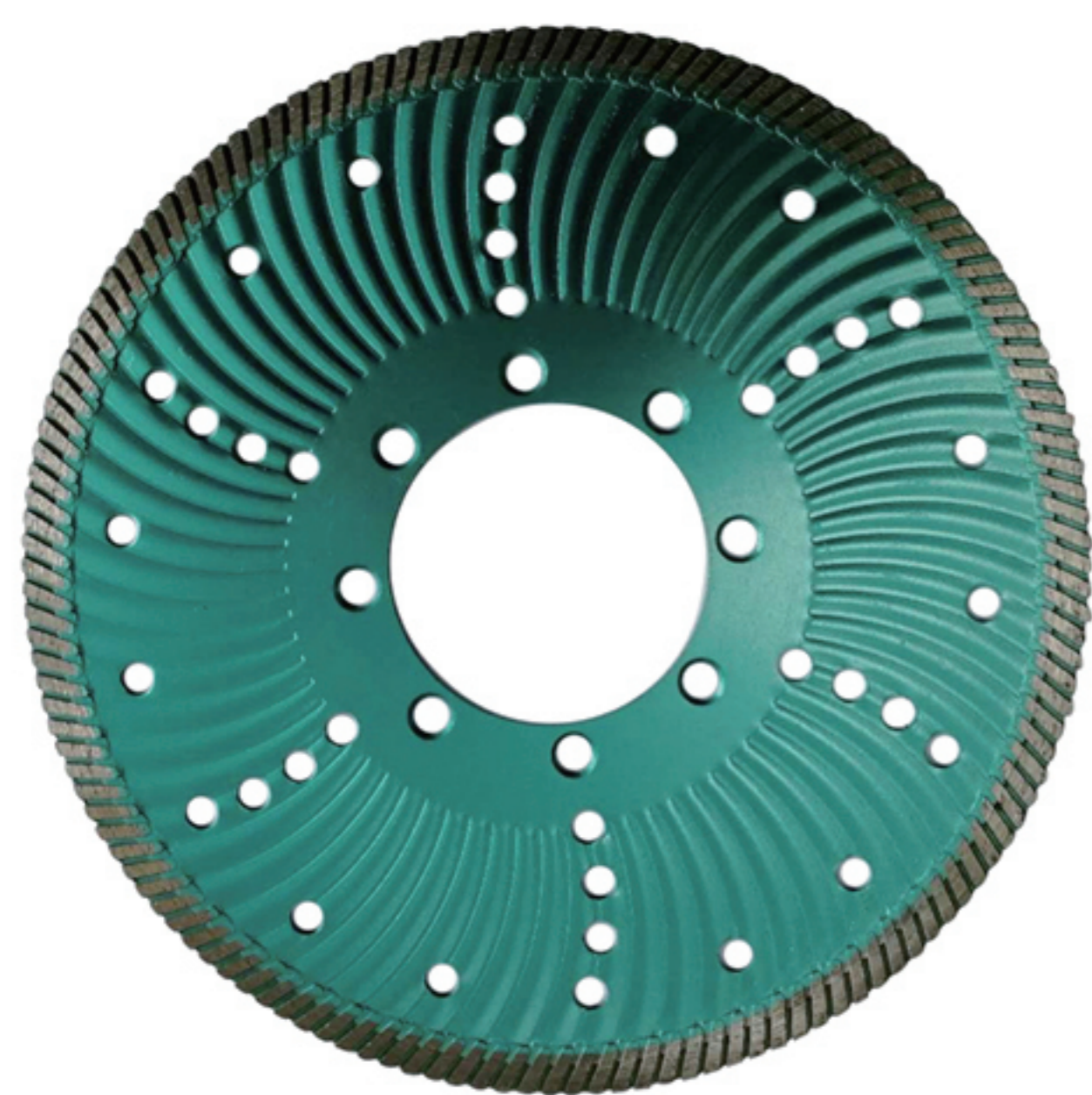

Outer Diameter		Hole Diameter	Segment Dimension
Metric (MM)	Inch		
105	4"	16/20/22.23	2.0x7.0
110	4.3"	16/20/22.23	2.0x7.0
115	4.5"	20/22.23	2.0x7.0
125	5"	20/22.23	2.2x7.0
150	6"	20/22.23	2.2x7.0
180	7"	22.23/25.4/30	2.4x7.0
200	8"	22.23/25.4/30	2.6x7.0
230	9"	22.23/25.4/30	2.6x7.5
250	10"	22.23/25.4/30/50	2.8x8.0
300	12"	22.23/25.4/30/50	3.2x8.0

TURBO WITH FLANGE THREADING



*Other sizes are available

Outer Diameter		Hole Diameter	Segment Dimension
Metric (MM)	Inch		
115	4.5"	20/22.23	2.0x7.0
125	5"	20/22.23	2.2x7.0
150	6"	20/22.23	2.2x7.0
180	7"	22.23/25.4/30	2.4x7.0
200	8"	22.23/25.4/30	2.6x7.0
230	9"	22.23/25.4/30	2.6x7.5
250	10"	22.23/25.4/30/50	2.8x8.0
300	12"	22.23/25.4/30/50	3.2x8.0

STYLE DIAMOND SAW BLADE

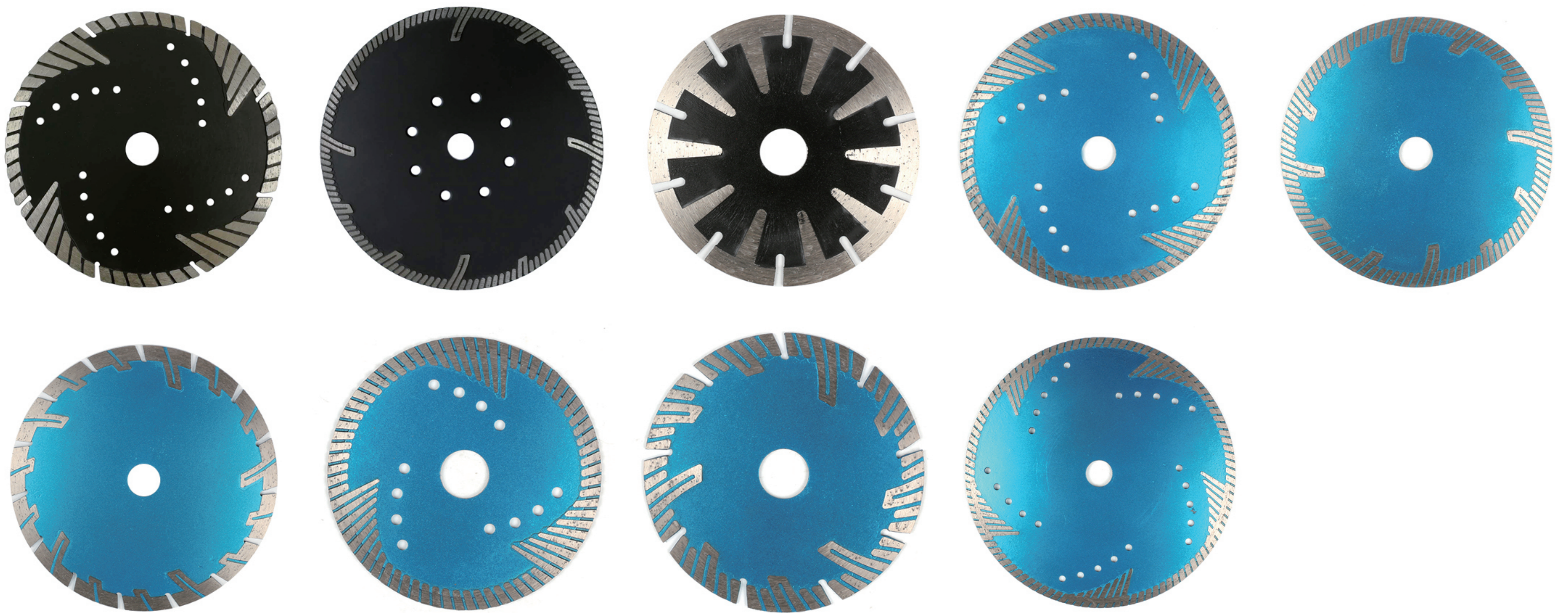

Outer Diameter		Hole Diameter	Segment Dimension
Metric(MM)	Inch	Metric(MM)	
105	4"	16/20/22.23	2.0x7.0
110	4.3"	16/20/22.23	2.0x7.0
115	4.5"	20/22.23	2.0x7.0
125	5"	20/22.23	2.2x7.0
150	6"	20/22.23	2.2x7.0
180	7"	22.23/25.4/30	2.4x7.0
200	8"	22.23/25.4/30	2.6x7.0
230	9"	22.23/25.4/30/50	2.6x7.2

TUCK POINT BLADE

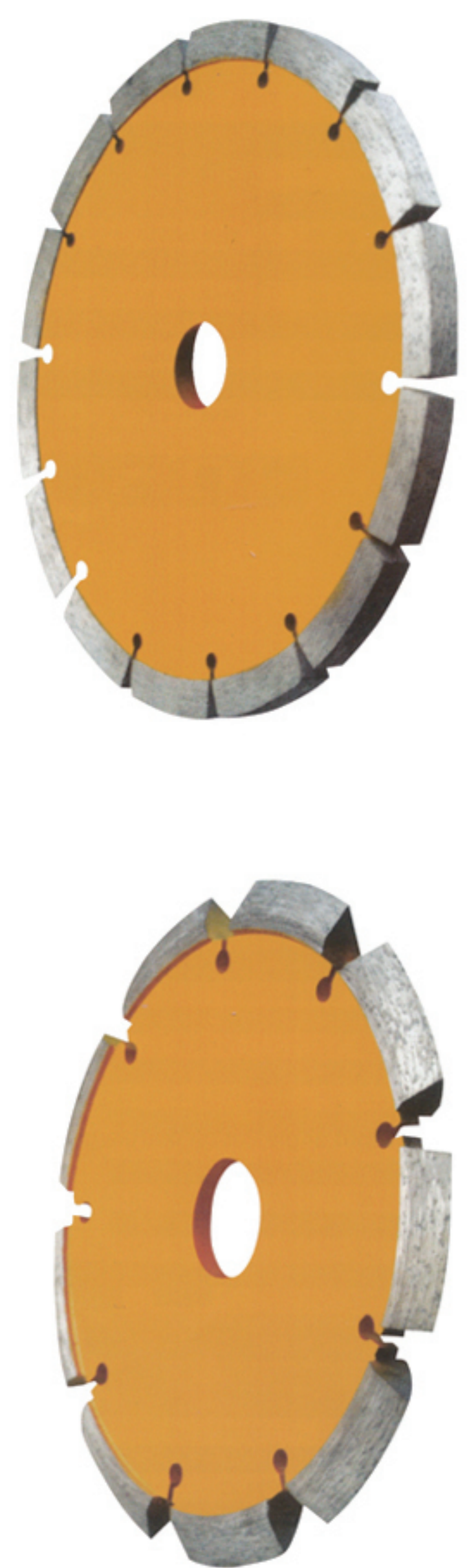

Outer Diameter		Hole Diameter	Segment Dimension
Metric (MM)	Inch	Metric (MM)	
80	3"	16/20/22.23	6.4x7.0x30
105	4"	16/20/22.23	6.4x7.0x35
110	4.3"	16/20/22.23	6.4x7.0x32.3
115	4.5"	20/22.23	6.4x7.0x34
125	5"	20/22.23	6.4x7.0x37.5
150	6"	20/22.23	6.4x7.0x35
180	7"	22.23/25.4/30	6.4x7.0x35
200	8"	22.23/25.4/30	6.4x7.0x34.6
230	9"	22.23/25.4/30/50	6.4x7.2x34.4
250	10"	22.23/25.4/30/50	6.4x7.2x34
300	12"	22.23/25.4/30/50	6.4x7.5x40
350	14"	22.23/25.4/30/50	6.4x7.5x40
400	16"	22.23/25.4/30/50	6.4x7.5x40

DIAMOND SAW BLADE-LASER/HIGH FREQUENCY WELDED

© LASER/HIGH FREQUENCY
WELDED SEGMENTED TURBO
DIAMOND SAW BLADE



Outer Diameter		Hole Diameter [MM]	Segment Dimension
Metric (MM)	Inch		
105	4"	16/20/22.23	2.0x12
110	4.3"	16/20/22.23	2.0x12
115	4.5"	20/22.23	2.0x12
125	5"	20/22.23	2.2x12
150	6"	20/22.23	2.2x12
180	7"	22.23/25.4/30	2.4x12
200	8"	22.23/25.4/30	2.6x12
230	9"	22.23/25.4/30/50	2.6x12
250	10"	22.23/25.4/30/50	3.0x12
300	12"	22.23/25.4/30/50	3.2x12
350	14"	22.23/25.4/30/50	3.2x12
400	16"	22.23/25.4/30/50	3.4x12

© LASER/HIGH FREQUENCY
WELDED SEGMENTED TURBO
DIAMOND SAW BLADE

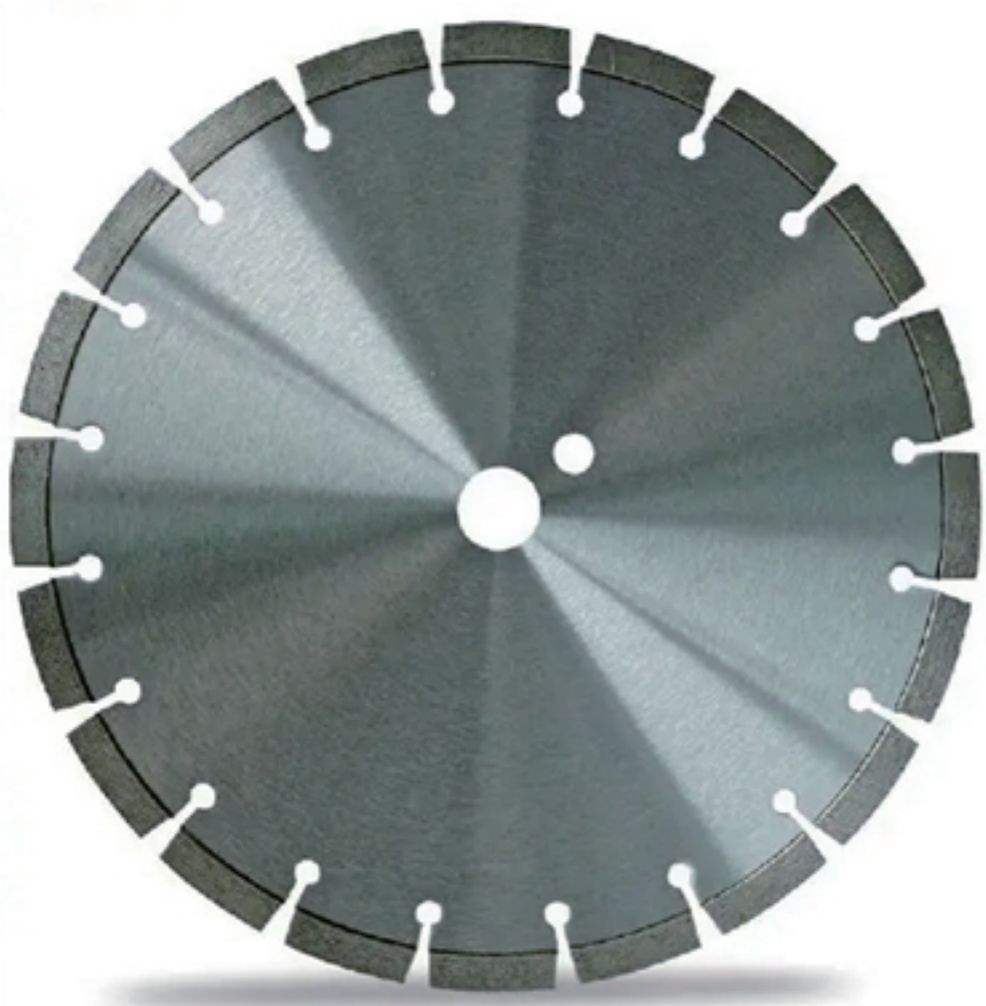

Outer Diameter		Hole Diameter [MM]	Segment Dimension	Segment Number
Metric (MM)	Inch			
230	9"	20/22.23	2.5x7x40	16
250	10"	22.23/25.4	2.5x7x40	17/18
300	12"	25.4/50	2.8x7x40	20/21
350	14"	25.4/50	2.8x7x40	24
400	16"	25.4/50	3.2x7x40	28
450	18"	25.4/50	3.2x7x40	32
500	20"	25.4/50	3.2x7x40	36
550	22"	25.4/50	3.2x7x40	38
600	24"	25.4/50	3.2x7x40	42
650	26"	25.4/50	3.2x7x40	44
700	28"	25.4/50	3.2x7x40	45

© General Purpose Brazed Saw
Blade

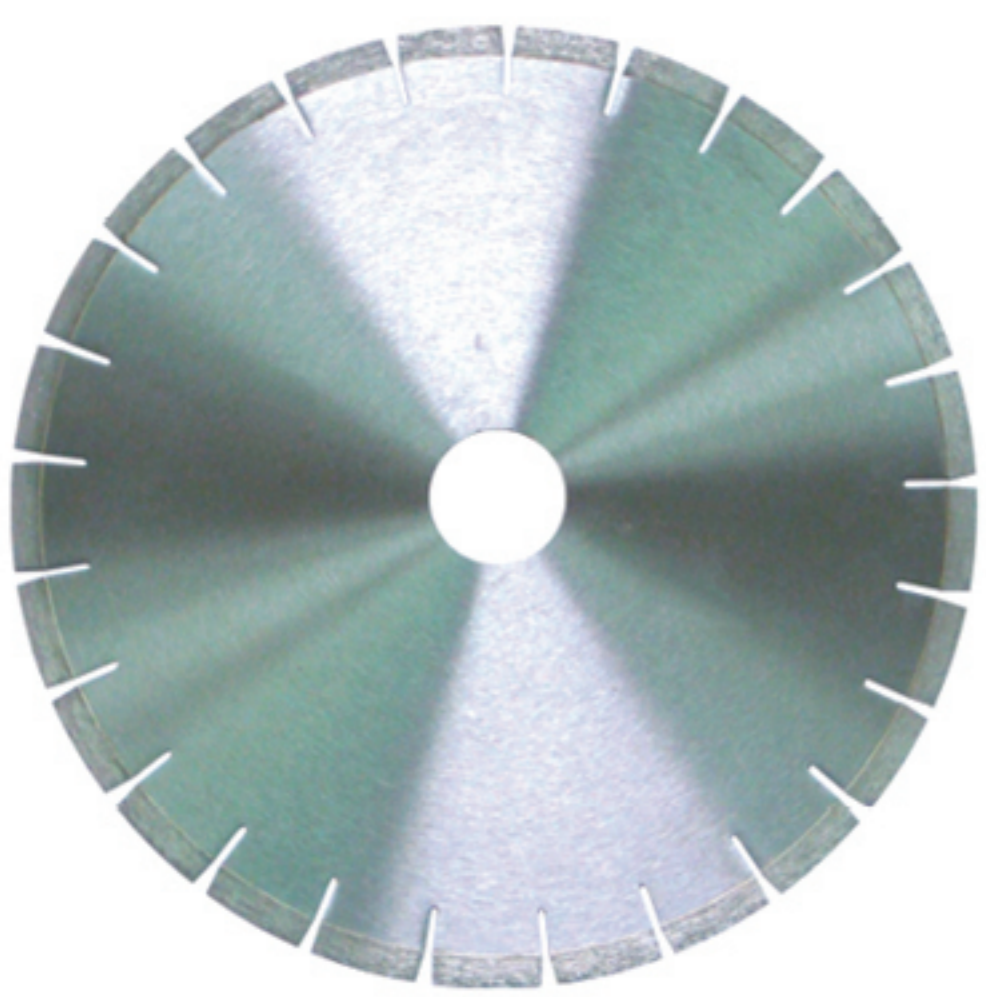

Outer Diameter		Hole Diameter		Segment Dimension (MM)		Segment Number
Metric (MM)	Inch	Metric (MM)	Inch	Thickness	Height	
230	9"	25.5/50	1"-2"	26	8-10	16
259	10"	25.5/50	1"-2"	2.8	8-10	18
300	12"	25.5/50	1"-2"	3.0	8-10	20
350	14"	25.5/50	1"-2"	3.2	8-10	24
400	16"	25.5/50	1"-2"	3.4	8-10	32
450	18"	25.5/50	1"-2"	3.6	8-10	36
500	20"	50/60	2"-23/8"	3.6	8-10	42
600	24"	50/60	2"-23/8"	4.2	8-10	50
700	28"	50/60	2"-23/8"	4.8	8	48
730	29"	50/60	2"-23/8"	5.8	10	48
800	32"	50/60	2"-23/8"	6.0	8-10	64
900	36"	80/100	3"-4"	6.5	10-12	70

© ASPHALT.GREEN(DEEP-DROP SEGMENT)

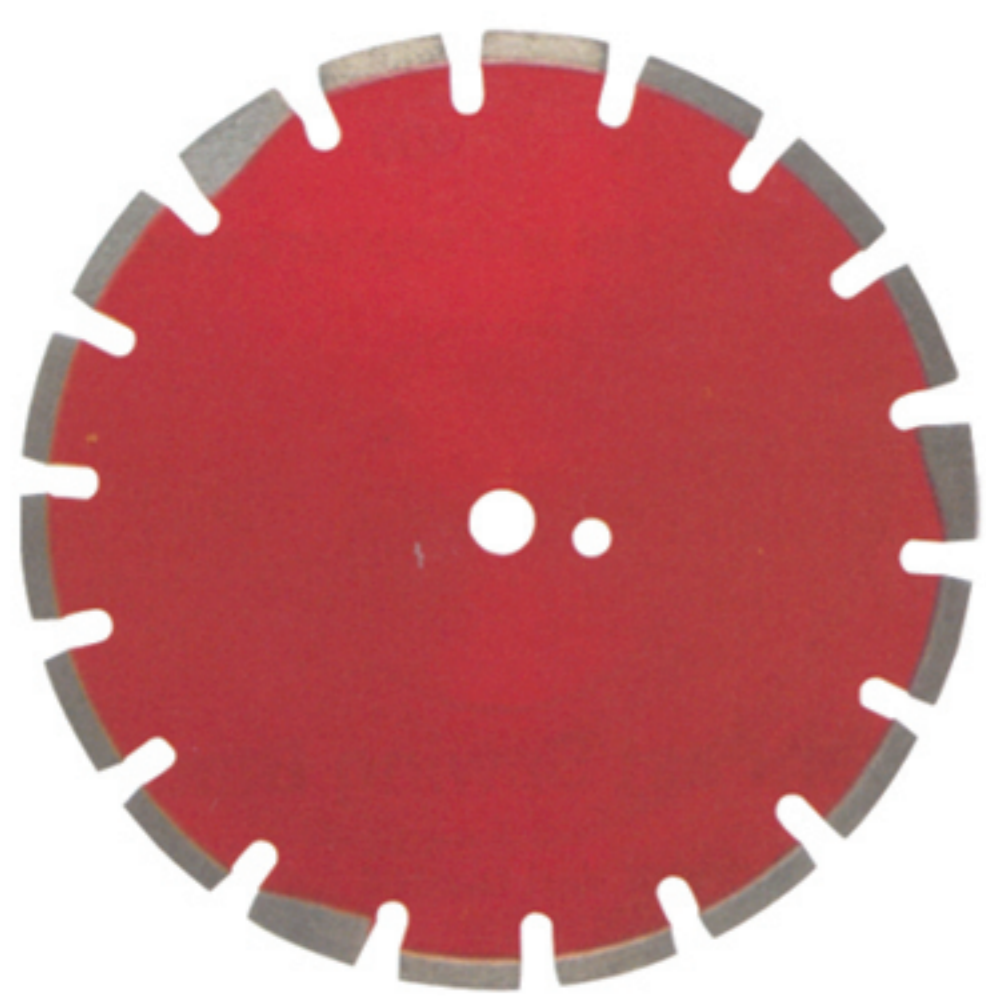

Outer Diameter		Hole Diameter		Segment Dimension (MM)		Segment Number
Metric (MM)	Inch	Metric (MM)	Inch	Thickness	Height	
105	12"	22.2/25.4/50	7/8"-2"	3.0	8-14	20/21
110	14"	22.2/25.4/50	7/8"-2"	3.2	8-14	24
115	16"	22.2/25.4/50	7/8"-2"	3.4	8-14	28
125	18"	22.2/25.4/50	7/8"-2"	3.6	8-14	32
150	20"	22.2/25.4/50	7/8"-2"	3.6	8-14	36

DIAMOND SAW BLADE- LASER/HIGH FREQUENCY WELDED

© ASPHALT/GREEN
CONCRETE

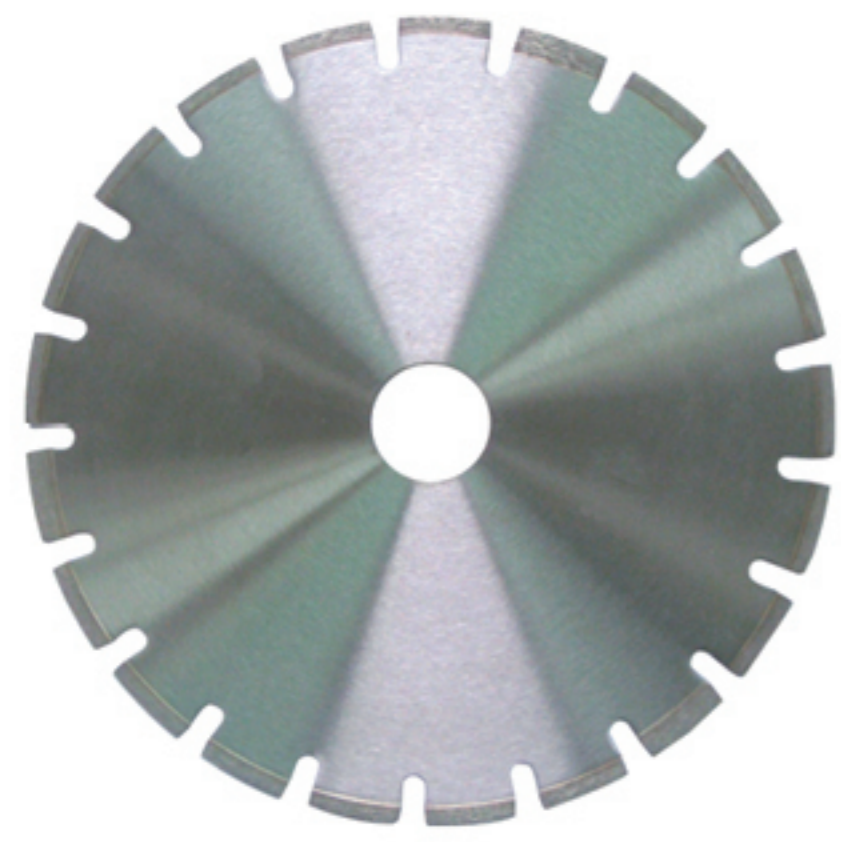

Outer Diameter		Hole Diameter		Sement Dimension(MM)		Segment Number
Metric (MM)	Inch	Metric (MM)	Inch	Thickness	Height	
230	9"	25.5/50	1"-2"	26	8-10	16
259	10"	25.5/50	1"-2"	2.8	8-10	18
300	12"	25.5/50	1"-2"	3.0	8-10	20
350	14"	25.5/50	1"-2"	3.2	8-10	24
400	16"	25.5/50	1"-2"	3.4	8-10	32
450	18"	25.5/50	1"-2"	3.6	8-10	36
500	20"	50/60	2"-23/8"	3.6	8-10	42
600	24"	50/60	2"-23/8"	4.2	8-10	50
700	28"	50/60	2"-23/8"	4.8	8	48
730	29"	50/60	2"-23/8"	5.8	10	48
800	32"	50/60	2"-23/8"	6.0	8-10	64
900	36"	80/100	3"-4"	6.5	10-12	70

© HIGH FREQUENCY WELDED
DIAMOND SAW BLADE

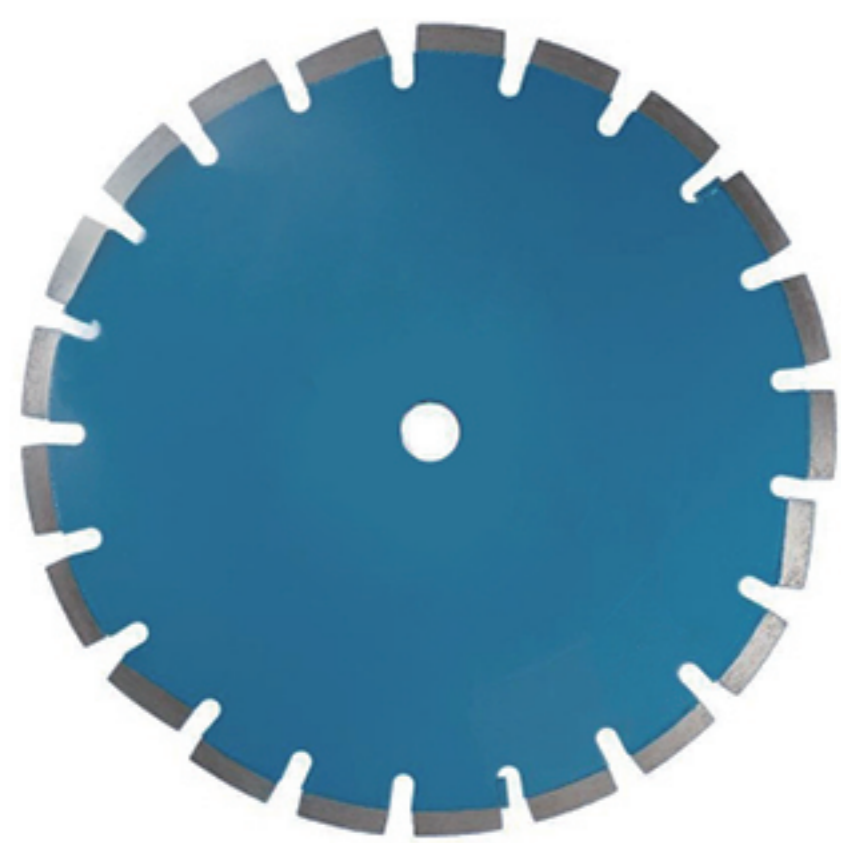

Outer Diameter (MM)	Outer Diameter Inch	Hole Diameter (MM)	Segment Dimension	Segment Number
230	9"	20/22.23	2.5x7x40	16
250	10"	22.23/25.4	2.5x7x40	17/18
300	12"	25.4/50	2.8x7x40	20/21
350	14"	25.4/50	2.8x7x40	24
400	16"	25.4/50	3.2x7x40	28
450	18"	25.4/50	3.2x7x40	32
500	20"	25.4/50	3.2x7x40	36
550	22"	25.4/50	3.2x7x40	38
600	24"	25.4/50	3.2x7x40	42
650	26"	25.4/50	3.2x7x40	44
700	28"	25.4/50	3.2x7x40	45

© HIGH FREQUENCY WELDED
DIAMOND SAW BLADE

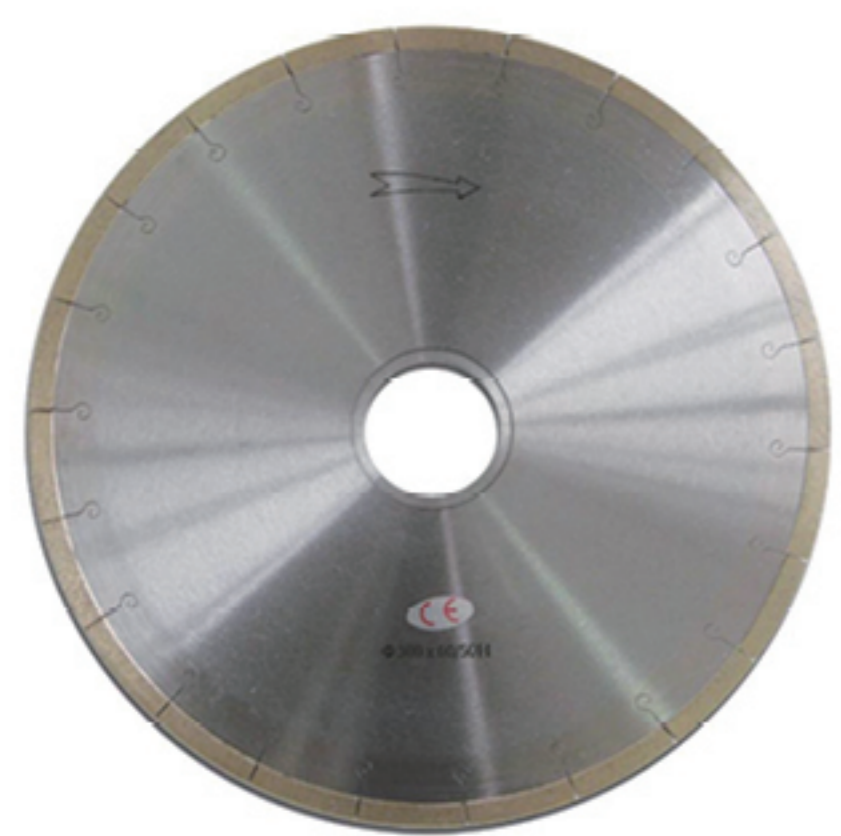

Outer Diameter (MM)	Outer Diameter Inch	Hole Diameter [MM]	Segment Dimension
105	4"	16/20/22.23	1.2x10
110	4.3"	16/20/22.23	1.2x10
115	4.5"	20/22.23	1.2x10
125	5"	20/22.23	1.4x10
150	6"	20/22.23	1.4x10
180	7"	22.23/25.4/30	1.6x10
200	8"	22.23/25.4/30	1.6x10
230	9"	22.23/25.4/30/50	1.6x10
250	10"	22.23/25.4/30/50	2.0x10
300	12"	22.23/25.4/30/50	2.2x10
350	14"	22.23/25.4/30/50	2.5x10
400	16"	22.23/25.4/30/50	2.6x10

ELECTROPLATED SAW BLADE

