

HSS TWIST DRILL









INSTRUCTION FOR HSS TWIST DRILL

1. PRODUCTION TECHNICS

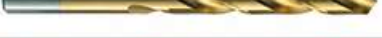
	Roll Forged
	Roll & Edge Ground
	Fully Ground



2. SURFACE FINISHING

	Black Finished
	Black & Bright
	Bright Finished
	Tin Coated
	Rainbow Color
	Bronze Oxide
	Black & Gold
	Amber

3. MATERIAL

HSS-M2/W9341/W4341/W4241	Roll Forged/Edge Ground
HSS-M35/M2/W9341/W4341/W4241	Fully Ground

4. CUTTING EDGE

	118° General Angle
	118° / 135° Split Point

5. REDUCED SHANK

	1/4 shank(6.5mm)
	3/8 shank(10.0mm)
	1/2 shank(13.0mm)

DIN338 HSS STRAIGHT SHANK TWIST DRILL

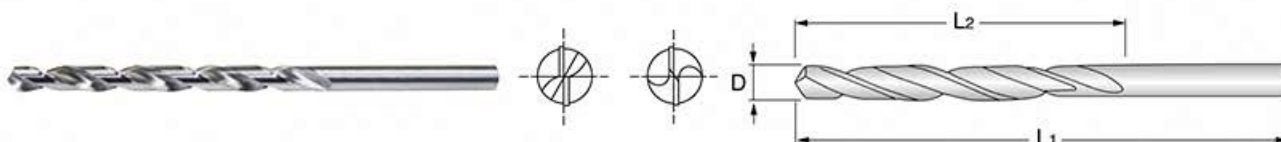

DRILLING TOOLS

DRILLING TOOLS

DIN338

mm

Dia.	L2	L1	Dia.	L2	L1	Dia.	L2	L1
1	12	34	4.8	52	86	10.6	87	133
1.05	12	34	4.9	52	86	10.7	94	142
1.1	14	36	5	52	86	10.8	94	142
1.15	14	36	5.1	52	86	10.9	94	142
1.2	16	38	5.2	52	86	11	94	142
1.25	16	38	5.3	52	86	11.1	94	142
1.3	16	38	5.4	57	93	11.2	94	142
1.35	18	40	5.5	57	93	11.3	94	142
1.4	18	40	5.6	57	93	11.4	94	142
1.45	18	40	5.7	57	93	11.5	94	142
1.5	18	40	5.8	57	93	11.6	94	142
1.55	20	43	5.9	57	93	11.7	94	142
1.6	20	43	6	57	93	11.8	94	142
1.65	20	43	6.1	63	101	11.9	101	151
1.7	20	43	6.2	63	101	12	101	151
1.75	22	46	6.3	63	101	12.1	101	151
1.8	22	46	6.4	63	101	12.2	101	151
1.85	22	46	6.5	63	101	12.3	101	151
1.9	22	46	6.6	63	101	12.4	101	151
1.95	24	46	6.7	63	101	12.5	101	151
2	24	49	6.8	69	109	12.6	101	151
2.05	24	49	6.9	69	109	12.7	101	151
2.1	24	49	7	69	109	12.8	101	151
2.15	27	53	7.1	69	109	12.9	101	151
2.2	27	53	7.2	69	109	13	101	151
2.25	27	53	7.3	69	109	13.1	101	151
2.3	27	53	7.4	69	109	13.2	101	151
2.35	27	53	7.5	69	109	13.3	108	160
2.4	30	57	7.6	75	117	13.4	108	160
2.45	30	57	7.7	75	117	13.5	108	160
2.5	30	57	7.8	75	117	13.6	108	160
2.55	30	57	7.9	75	117	13.7	108	160
2.6	30	57	8	75	117	13.8	108	160
2.65	30	57	8.1	75	117	13.9	108	160
2.7	33	61	8.2	75	117	14	108	160
2.75	33	61	8.3	75	117	14.25	114	169
2.8	33	61	8.4	75	117	14.5	114	169
2.85	33	61	8.5	75	117	14.75	114	169
2.9	33	61	8.6	75	125	15	114	169
2.95	33	61	8.7	81	125	15.25	120	178
3	33	61	8.8	81	125	15.5	120	178
3.1	36	65	8.9	81	125	15.75	120	178
3.2	36	65	9	81	125	16	120	178
3.3	36	65	9.1	81	125	16.25	125	184
3.4	39	70	9.2	81	125	16.5	125	184
3.5	39	70	9.3	81	125	16.75	125	184
3.6	39	70	9.4	81	125	17	125	184
3.7	39	70	9.5	81	125	17.25	130	191
3.8	43	75	9.6	81	125	17.5	130	191
3.69	43	75	9.7	81	133	17.75	130	191
4	43	75	9.8	87	133	18	130	191
4.1	43	75	9.9	87	133	18.25	135	198
4.2	43	75	10	87	133	18.5	135	198
4.3	47	80	10.1	87	133	18.75	135	198
4.4	47	80	10.2	87	133	19	135	198
4.5	47	80	10.3	87	133	19.25	140	205
4.6	47	80	10.4	87	133	19.5	140	205
4.7	47	80	10.5	87	133	19.75	140	205
						20	140	205

DIN338 HSS REDUCE SHANK TWIST DRILL

DRILLING TOOLS

DRILLING TOOLS

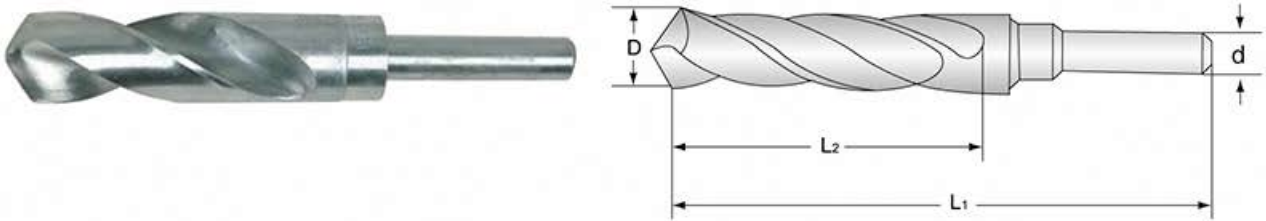

D	L2	L1	d
10.5	87	133	10.0
11	94	142	10.0
11.5	94	142	10.0
12	101	151	10.0
12.5	101	151	10.0
13	101	151	10.0
13.5	108	160	10.0
13.5	108	160	13.0
14	108	160	10.0
14	108	160	13.0
14.5	114	169	10.0
14.5	114	169	13.0
15	114	169	10.0
15	114	169	13.0
15.5	120	178	10.0
15.5	120	178	13.0
16	120	178	10.0
16	120	178	13.0
16.5	125	184	10.0
16.5	125	184	13.0
17	125	184	10.0
17	125	184	13.0
17.5	130	191	13.0
18	130	191	10.0
18	130	191	13.0
18.5	135	198	13.0
19	135	198	13.0
19.5	140	205	13.0
20	140	205	10.0
20	140	205	13.0

DIN340 HSS STRAIGHT SHANK TWIST DRILL

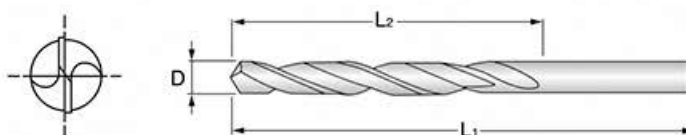

DRILLING TOOLS

DRILLING TOOLS

DIN340 mm

Dia.	L2	L1	Dia.	L2	L1	Dia.	L2	L1	Dia.	L2	L1
1	33	56	5	87	132	9	115	175	13	134	205
1.1	37	60	5.1	87	132	9.1	115	175	13.1	134	205
1.2	41	65	5.2	87	132	9.2	115	175	13.2	134	205
1.3	41	65	5.3	87	132	9.3	115	175	13.3	140	214
1.4	45	70	5.4	91	139	9.4	115	175	13.4	140	214
1.5	45	70	5.5	91	139	9.5	115	175	13.5	140	214
1.6	50	76	5.6	91	139	9.6	121	175	13.6	140	214
1.7	50	76	5.7	91	139	9.7	121	184	13.7	140	214
1.8	53	80	5.8	91	139	9.8	121	184	13.8	140	214
1.9	53	80	5.9	91	139	9.9	121	184	13.9	140	214
2	56	85	6	91	139	10	121	184	14	140	214
2.1	56	85	6.1	97	148	10.1	121	184	14.25	144	220
2.2	56	90	6.2	97	148	10.2	121	184	14.5	144	220
2.3	56	90	6.3	97	148	10.3	121	184	14.75	144	220
2.4	62	95	6.4	97	148	10.4	121	184	15	144	220
2.5	62	95	6.5	97	148	10.5	121	184	15.25	149	227
2.6	62	95	6.6	97	148	10.6	121	184	15.5	149	227
2.7	66	100	6.7	97	148	10.7	128	195	15.75	149	227
2.8	66	100	6.8	102	148	10.8	128	195	16	149	227
2.9	66	100	6.9	102	156	10.9	128	195	16.25	154	235
3	63	100	7	102	156	11	128	195	16.5	154	235
3.1	69	106	7.1	102	156	11.1	128	195	16.75	154	235
3.2	69	106	7.2	102	156	11.2	128	195	17	154	235
3.3	69	106	7.3	102	156	11.3	128	195	17.25	158	241
3.4	73	110	7.4	102	156	11.4	128	195	17.5	158	241
3.5	73	110	7.5	102	156	11.5	128	195	17.75	158	241
3.6	73	110	7.6	109	156	11.6	128	195	18	158	241
3.7	73	110	7.7	109	165	11.7	128	195	18.25	162	247
3.8	78	119	7.8	109	165	11.8	128	195	18.5	162	247
3.9	78	119	7.9	109	165	11.9	134	205	18.75	162	247
4	78	119	8	109	165	12	134	205	19	162	247
4.1	78	119	8.1	109	165	12.1	134	205	19.25	166	254
4.2	82	126	8.2	109	165	12.2	134	205	19.5	166	254
4.3	82	126	8.3	109	165	12.3	134	205	19.75	166	254
4.4	82	126	8.4	109	165	12.4	134	205	20	166	254
4.5	82	126	8.5	109	165	12.5	134	205			
4.6	82	126	8.6	115	165	12.6	134	205			
4.7	82	132	8.7	115	175	12.7	134	205			
4.8	87	132	8.8	115	175	12.8	134	205			
4.9	87	132	8.9	115	175	12.9	134	205			

DIN1897 HSS STRAIGHT SHANK TWIST DRILL

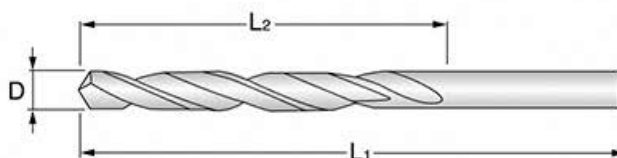
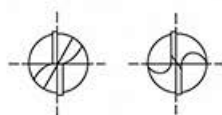

DRILLING TOOLS

DRILLING TOOLS

DIN1897

mm

Dia.	L2	L1	Dia.	L2	L1	Dia.	L2	L1	Dia.	L2	L1
1	6	26	5	26	62	9	40	84	13	51	102
1.1	7	28	5.1	26	62	9.1	40	84	13.1	51	102
1.2	8	30	5.2	26	62	9.2	40	84	13.2	51	102
1.3	8	30	5.3	28	66	9.3	40	84	13.3	54	107
1.4	9	32	5.4	28	66	9.4	40	84	13.4	54	107
1.5	9	32	5.5	28	66	9.5	40	84	13.5	54	107
1.6	10	34	5.6	28	66	9.6	43	89	13.6	54	107
1.7	10	34	5.7	28	66	9.7	43	89	13.7	54	107
1.8	11	36	5.8	28	66	9.8	43	89	13.8	54	107
1.9	11	36	5.9	28	66	9.9	43	89	13.9	54	107
2	12	38	6	28	66	10	43	89	14	54	107
2.1	12	38	6.1	31	70	10.1	43	89	14.25	56	111
2.2	13	40	6.2	31	70	10.2	43	89	14.5	56	111
2.3	13	40	6.3	31	70	10.3	43	89	14.75	56	111
2.4	14	43	6.4	31	70	10.4	43	89	15	56	111
2.5	14	43	6.5	31	70	10.5	43	98	15.25	58	115
2.6	14	43	6.6	31	70	10.6	43	98	15.5	58	115
2.7	16	46	6.7	31	70	10.7	47	95	15.75	58	115
2.8	16	46	6.8	34	74	10.8	47	95	16	58	115
2.9	16	46	6.9	34	74	10.9	47	95	16.25	58	119
3	16	46	7	34	74	11	47	95	16.5	58	119
3.1	18	49	7.1	34	74	11.1	47	95	16.75	58	119
3.2	18	49	7.2	34	74	11.2	47	95	17	58	119
3.3	18	49	7.3	34	74	11.3	47	95	17.25	62	123
3.4	20	52	7.4	34	74	11.4	47	95	17.5	62	123
3.5	20	52	7.5	34	74	11.5	47	95	17.75	62	123
3.6	20	52	7.6	37	79	11.6	47	95	18	62	123
3.7	20	52	7.7	37	79	11.7	47	95	18.25	62	127
3.8	22	55	7.8	37	79	11.8	47	95	18.5	62	127
3.9	22	55	7.9	37	79	11.9	51	102	18.75	62	127
4	22	55	8	37	79	12	51	102	19	62	127
4.1	22	55	8.1	37	79	12.1	51	102	19.25	66	131
4.2	22	55	8.2	37	79	12.2	51	102	19.5	66	131
4.3	24	58	8.3	37	79	12.3	51	102	19.75	66	131
4.4	24	58	8.4	37	79	12.4	51	102	20	66	131
4.5	24	58	8.5	37	79	12.5	51	102			
4.6	24	58	8.6	40	84	12.6	51	102			
4.7	24	58	8.7	40	84	12.7	51	102			
4.8	26	62	8.8	40	84	12.8	51	102			
4.9	26	62	8.9	40	84	12.9	51	102			

DIN345 HSS TAPER SHANK TWIST DRILL

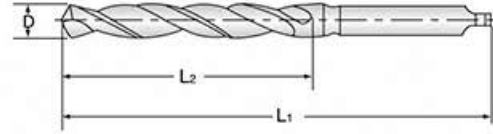

Roll forged / milled

Dia.	L2	L1	Dia.	L2	L1	Dia.	L2	L1
8	75	156	21.75	150	248	39	200	349
8.2	75	156	22	150	248	39.5	200	349
8.5	75	156	22.25	150	253	40	200	349
8.8	81	162	22.5	155	253	40.5	205	354
9	81	162	22.75	155	253	41	205	354
9.2	81	162	23	155	253	41.5	205	354
9.5	81	162	23.25	155	276	42	205	354
9.8	87	168	23.5	155	276	42.5	205	354
10	87	168	23.75	160	281	43	210	359
10.2	87	168	24	160	281	43.5	210	359
10.5	87	168	24.25	160	281	44.5	210	359
10.8	94	175	24.5	160	281	45	210	359
11	94	175	24.75	160	281	45.5	215	364
11.2	94	175	25	160	281	46	215	364
11.5	94	175	25.25	165	286	46.5	215	364
11.8	94	175	25.5	165	286	47	215	364
12	101	182	25.75	165	286	47.5	215	364
12.2	101	182	26	165	286	48	220	369
12.5	101	182	26.25	165	286	48.5	220	369
12.8	101	182	26.5	165	286	49	220	369
13	101	182	26.75	170	291	49.5	220	369
13.2	101	182	27	170	291	50	220	369
13.5	108	189	27.25	170	291	50.5	220	374
13.8	108	189	27.5	170	291	51	225	412
14	108	189	27.75	170	291	52	225	412
14.25	114	212	28	170	291	53	225	412
14.5	114	212	28.25	175	296	54	230	417
14.75	114	212	28.5	175	296	55	230	417
15	114	212	28.75	175	296	56	230	417
15.25	120	218	29	175	296	57	235	422
15.5	120	218	29.25	175	296	58	235	422
15.75	120	218	29.5	175	296	59	235	422
16	120	218	29.75	175	296	60	235	422
16.25	125	223	30	175	296	61	240	427
16.5	125	223	30.25	180	301	62	240	427
16.75	125	223	30.5	180	301	63	240	427
17	125	223	30.75	180	301	64	245	432
17.25	130	223	31	180	301	65	245	432
17.5	130	228	31.25	180	301	66	245	432
17.75	130	228	31.5	180	301	67	245	432
18	130	228	31.75	185	306	68	250	437
18.5	135	233	32	185	334	69	250	437
18.75	135	233	32.5	185	334	70	250	437
19	135	233	33	185	334	71	250	437
19.25	140	238	33.5	185	334	72	255	442
19.5	140	238	34	190	339	73	255	442
19.75	140	238	34.5	190	339	74	255	442
20	140	243	35	190	339	75	255	442
20.25	145	243	35.5	190	339	76	260	447
20.5	145	243	36	195	344			
20.75	145	243	36.5	195	344			
21	145	248	37	195	344			
21.25	150	248	38	200	349			
21.5	150	248	38.5	200	349			

DIN341 HSS TAPER SHANK TWIST DRILL



Roll forged / milled

D	FL	OAL	MT	D	FL	OAL	MT	D	FL	OAL	MT
5.0	74	155	1	17.25	165	283	2	29.25	230	351	3
5.2	74	155	1	17.50	165	283	2	29.50	230	351	3
5.5	80	161	1	17.75	165	283	2	29.75	230	351	3
5.8	80	161	1	18.00	165	283	2	30.00	230	351	3
6.0	80	161	1	18.25	171	269	2	30.25	239	360	3
6.2	88	167	1	18.50	171	269	2	30.50	239	360	3
6.5	88	167	1	18.75	171	269	2	30.75	239	360	3
6.8	93	174	1	19.00	171	269	2	31.00	239	360	3
7.0	93	174	1	19.25	177	275	2	31.25	239	360	3
7.2	93	174	1	19.50	177	275	2	31.50	239	360	3
7.5	93	174	1	19.75	177	275	2	31.75	248	369	3
7.8	100	181	1	20.00	177	275	2	32.00	248	397	3
8.0	100	181	1	20.25	184	282	2	32.50	248	397	4
8.2	100	181	1	20.50	184	282	2	33.00	248	397	4
8.5	100	181	1	20.75	184	282	2	33.50	248	397	4
8.8	107	188	1	21.00	184	282	2	34.00	257	406	4
9.0	107	188	1	21.25	191	289	2	34.50	257	406	4
9.2	107	188	1	21.50	191	289	2	35.00	257	406	4
9.5	107	188	1	21.75	191	289	2	35.50	257	406	4
9.8	116	197	1	22.00	191	289	2	36.00	267	416	4
10.0	116	197	1	22.25	191	289	2	36.50	267	416	4
10.2	116	197	1	22.50	198	296	2	37.00	267	416	4
10.5	116	197	1	22.75	198	296	2	37.50	267	416	4
10.8	125	206	1	23.00	198	296	2	38.00	277	426	4
11.0	125	206	1	23.25	198	319	3	38.50	277	426	4
11.2	125	206	1	23.50	198	319	3	39.00	277	426	4
11.5	125	206	1	23.75	208	327	3	39.50	277	426	4
11.8	125	206	1	24.00	208	327	3	40.00	277	426	4
12.0	134	215	1	24.25	208	327	3	40.50	287	436	4
12.2	134	215	1	24.50	208	327	3	41.00	287	436	4
12.5	134	215	1	24.75	208	327	3	41.50	287	436	4
12.8	134	215	1	25.00	208	327	3	42.00	287	436	4
13.0	134	215	1	25.25	214	335	3	42.50	287	436	4
13.2	134	215	1	25.50	214	335	3	43.00	298	447	4
13.5	142	223	1	25.75	214	335	3	43.50	298	447	4
13.8	142	223	1	26.00	214	335	3	44.00	298	447	4
14.0	142	223	1	26.25	214	335	3	44.50	298	447	4
14.2	147	245	2	26.50	214	335	3	45.00	298	447	4
14.5	147	245	2	26.75	222	343	3	45.50	310	459	4
14.8	147	245	2	27.00	222	343	3	46.00	310	459	4
15.0	147	245	2	27.25	222	343	3	46.50	310	459	4
15.2	153	251	2	27.50	222	343	3	47.00	310	459	4
15.5	153	251	2	27.75	222	343	3	47.50	310	459	4
15.8	153	251	2	28.00	222	343	3	48.00	321	470	4
16.0	153	251	2	28.25	230	351	3	48.50	321	470	4
16.2	159	257	2	28.50	230	351	3	49.00	321	470	4
16.5	159	257	2	28.75	230	351	3	49.50	321	470	4
16.8	159	257	2	29.00	230	351	3	50.00	321	470	4
17.0	159	257	2								

HSS DOUBLE END DRILL

- 制造工艺: 全磨制
 - 可选材料: 高速钢或含钴高速钢
 - 被加工件: 钢件、铸铁及其他软金属
 - 表面处理: 白钻、黑钻、镀钛
 - 可选规格: 2.0~10.0MM
- PROCESS:FULLY-GROUND
 - MATERIALS:HSS OR HSS-COBALT
 - APPLICATION MATERIAL:STEEL,CASTIRON OR OTHER SOFT METAL
 - SURFACE TREATMENT:WHITE,BLACK,TIN-COATED
 - SIZE:2.0~10.0MM

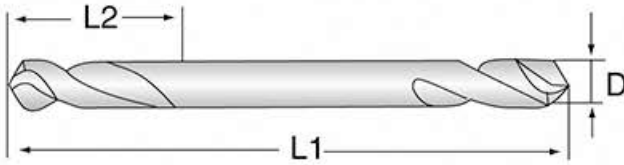

DRILLING TOOLS

DRILLING TOOLS

D	L1	L2	D	L1	L2	D	L1	L2
2.00	38.0	7.5	6.00	66.0	19.0	7/64"	1-7/8"	1/2"
2.10	38.0	7.5	6.10	70.0	21.2	1/8"	2"	1/2"
2.20	38.0	7.5	6.20	70.0	21.2	9/64"	2"	1/2"
2.30	38.0	7.5	6.30	70.0	21.2	5/32"	2-1/16"	1/2"
2.40	38.0	7.5	6.40	70.0	21.2	3/16"	2-3/16"	1/2"
2.50	43.0	9.5	6.50	70.0	21.2	7/32"	2-3/8"	1/2"
2.60	43.0	9.5	6.60	70.0	21.2	1/4"	3-1/2"	1/2"
2.70	46.0	10.6	6.70	70.0	23.6	30#	2"	1/2"
2.80	46.0	10.6	6.80	74.0	23.6	20#	2-1/8"	1/2"
2.90	46.0	10.6	6.90	74.0	23.6	11#	2-1/4"	1/2"
3.00	46.0	10.6	7.00	74.0	23.6			
3.10	49.0	11.2	7.10	74.0	23.6			
3.20	49.0	11.2	7.20	74.0	23.6			
3.25	49.0	11.2	7.30	74.0	23.6			
3.30	49.0	11.2	7.40	74.0	23.6			
3.40	52.0	12.5	7.50	74.0	25.0			
3.50	52.0	12.5	7.60	79.0	25.0			
3.60	52.0	12.5	7.70	79.0	25.0			
3.70	52.0	12.5	7.80	79.0	25.0			
3.80	55.0	14.0	7.90	79.0	25.0			
3.90	55.0	14.0	8.00	79.0	25.0			
4.00	55.0	14.0	8.10	79.0	25.0			
4.10	55.0	14.0	8.20	79.0	25.0			
4.20	55.0	14.0	8.30	79.0	25.0			
4.30	58.0	15.5	8.40	79.0	25.0			
4.40	58.0	15.5	8.50	79.0	25.0			
4.50	58.0	15.5	8.60	84.0	25.0			
4.60	58.0	15.5	8.70	84.0	25.0			
4.70	58.0	15.5	8.80	84.0	25.0			
4.80	62.0	17.0	8.90	84.0	25.0			
4.90	62.0	17.0	9.00	84.0	25.0			
5.00	62.0	17.0	9.10	84.0	25.0			
5.10	62.0	17.0	9.20	84.0	25.0			
5.20	62.0	17.0	9.30	84.0	25.0			
5.30	62.0	17.0	9.40	84.0	25.0			
5.40	66.0	19.0	9.50	84.0	25.0			
5.50	66.0	19.0	9.60	84.0	25.0			
5.60	66.0	19.0	9.70	89.0	25.0			
5.70	66.0	19.0	9.80	89.0	25.0			
5.80	66.0	19.0	9.90	89.0	25.0			
5.90	66.0	19.0	10.00	89.0	25.0			

DIN1869 EXTRA LENGTH HSS TWIST DRILL

- 制造工艺: 全磨制
 - 可选材料: 高速钢或含钴高速钢
 - 被加工件: 钢件、铸铁及其他软金属
 - 表面处理: 白钻、黑钻、镀钛
 - 可选规格: 2.0~13.0MM
- PROCESS:FULLY-GROUND
 - MATERIALS:HSS OR HSS-COBALT
 - APPLICATION MATERIAL:STEEL,CASTIRON OR OTHER SOFT METAL
 - SURFACE TREATMENT:WHITE,BLACK,TIN-COATED
 - SIZE:2.0~13.0MM

DRILLING TOOLS

DRILLING TOOLS

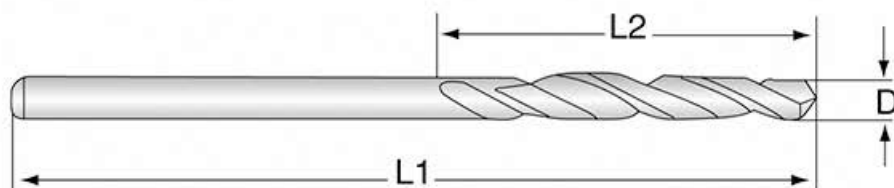

DIN1869-I			D	L1	L2	D	L1	L2
2.00	125	85	2.00	160	110	2.00	200	135
2.50	140	95	2.50	180	120	2.50	225	150
3.00	150	100	3.00	190	130	3.00	240	160
3.50	165	115	3.50	210	145	3.50	265	180
4.00	175	120	4.00	220	150	4.00	280	190
4.50	185	125	4.50	235	160	4.50	295	200
5.00	195	135	5.00	245	170	5.00	315	210
5.50	205	140	5.50	260	180	5.50	330	225
6.00	205	140	6.00	260	180	6.00	330	225
6.50	215	150	6.50	275	190	6.50	350	235
7.00	225	155	7.00	290	200	7.00	370	250
7.50	225	155	7.50	290	200	7.50	370	250
8.00	240	165	8.00	305	210	8.00	390	265
8.50	240	165	8.50	305	210	8.50	390	265
9.00	250	175	9.00	320	220	9.00	410	280
9.50	250	175	9.50	320	220	9.50	410	280
10.00	265	185	10.00	340	235	10.00	430	295
10.50	265	185	10.50	340	235	10.50	430	295
11.00	280	195	11.00	365	250	11.00	455	310
11.50	280	195	11.50	365	250	11.50	455	310
12.00	295	205	12.00	375	260	12.00	480	330
12.50	295	205	12.50	375	260	12.50	480	330
13.00	295	205	13.00	375	260	13.00	480	330

DIN333 HSS CENTER DRILLS

DRILLING TOOLS

DRILLING TOOLS

Type A			
d	D	L	l
1.00	3.15	33.50	1.90
1.25	3.15	33.50	1.90
1.60	4.00	37.50	2.80
2.00	5.00	42.00	3.30
2.50	6.30	47.00	4.10
3.15	8.00	52.00	4.90
4.00	10.00	59.00	6.20
5.00	12.50	66.00	7.50
6.30	16.00	74.00	9.20
8.00	20.00	80.00	11.5
10.00	22.00	100.00	14.2

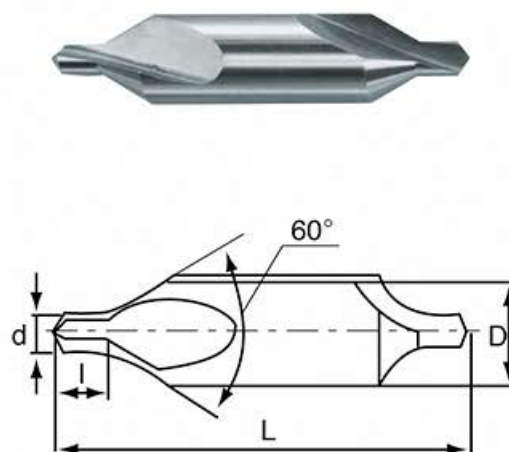

Type B			
d	D	L	l
1.00	4.00	37.50	1.90
1.25	5.00	42.00	2.20
1.60	6.30	47.00	2.80
2.00	8.00	52.50	3.30
2.50	10.00	59.00	4.10
3.15	11.20	63.00	4.90
4.00	14.00	70.00	6.20
5.00	18.00	78.00	7.50
6.30	20.00	83.00	9.20
8.00	22.00	100.00	11.5
10.00	28.00	125.00	14.2

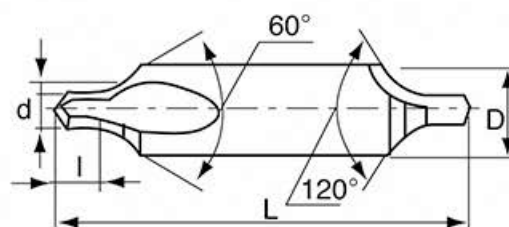

Type R				
d	D	L	l	r
1.00	3.15	33.50	3.00	2.50
1.25	3.15	33.50	3.35	3.15
1.60	4.00	37.50	4.25	4.00
2.00	5.00	42.00	5.30	5.00
2.50	6.30	47.00	6.70	6.30
3.15	8.00	52.00	8.50	8.00
4.00	10.00	59.00	10.60	10.00
5.00	12.50	66.00	13.20	12.50
6.30	16.00	74.00	17.00	16.00
8.00	20.00	80.00	21.20	20.00
10.00	22.00	100.00	26.50	25.00

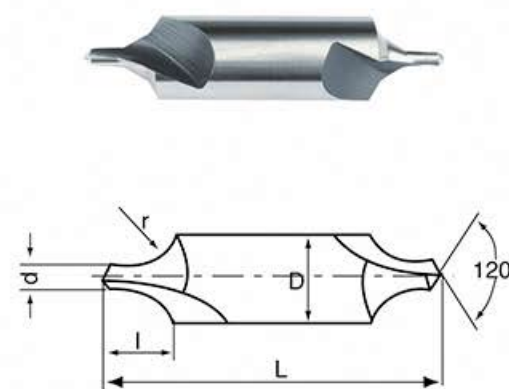

HSS SAW DRILLS

DRILL SAW

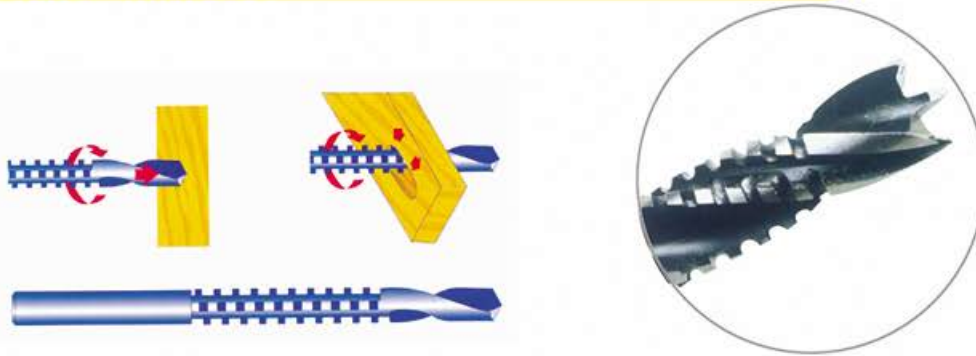

DRILL SAW

Art No.	Dia.		Flute length	L(Allover Length)
ECSD03	1/8"	3.0	35	61
ECSD04	5/32"	4.0	48	75
ECSD05	3/16"	5.0	53	85
ECSD06	7/32"	6.0	56	87
ECSD065	1/4"	6.5	56	87
ECSD08	5/16"	8.0	65	95
ECSD09	-	9.0	68	103
ECSD10	3/8"	10.0	72	110
ECSD12	15/32"	12.0	78	118
ECSD13	1/2"	13.0	90	130

DRILL SAW SET

<p>Art No.: ECSD101</p>	<p>Art No.: ECSD401</p>	<p>Art No.: ECSD402</p>
<p>Art No.: ECSD601</p>	<p>Art No.: ECSD602</p>	<p>Art No.: ECSD603</p>

HEX SHANK DRILL

▶ HSS HEX SHANK SHORT DRILLS



D	L2	L1
1.0	7	32
1.5	10	34
2.0	12	36
2.5	14	38
3.0	16	38
3.1	16	40
3.3	18	40
3.5	18	44
4.0	20	44
4.1	20	44
4.2	20	46
4.5	24	46
4.9	24	50
5.0	26	50
5.1	26	50
5.5	26	50
6.0	26	50
6.1	26	50
6.5	30	50
6.8	30	50
7.0	30	50
7.5	32	51
8.0	32	51
8.5	33	53
9.0	33	53
9.5	38	54
10.0	38	54
10.2	38	54
10.5	44	60
11.0	44	60
12.0	44	60
12.5	44	60
13.0	44	60

▶ HSS HEX SHANK DRILLS



Standard: DIN338 or Customized
 Size: $\phi 1.0 \sim \phi 13.0$ / 3/64"~1/2"
 Material: 4241, 4341, M2, M35
 Process: Fully Ground, Rolled
 Point Angle: 118°/135°



Standard: DIN338 or Customized
 Size: $\phi 1.0 \sim \phi 13.0$ / 3/64"~1/2"
 Material: 4241, 4341, M2, M35
 Process: Fully Ground, Rolled
 Point Angle: 118°/135°



Standard: DIN338 or Customized
 Size: $\phi 1.0 \sim \phi 13.0$ / 3/64"~1/2"
 Material: 4241, 4341, M2, M35
 Process: Fully Ground, Rolled
 Point Angle: 118°/135°



Standard: DIN338 or Customized
 Size: $\phi 1.0 \sim \phi 13.0$ / 3/64"~1/2"
 Material: 4241, 4341, M2, M35
 Process: Fully Ground, Rolled
 Point Angle: 118°/135°

HSS COUNTERSINK

DRILLING TOOLS

HSS COUNTERSINK BITS INCH SIZES



For thread	D	L1	d
#0	15/64"	1-3/4"	1/4"
#1	13/32"	1-3/4"	1/4"
#2	17/32"	2"	1/4"
#3	25/32"	2-3/4"	1/2"
#4	1-1/16"	3"	1/2"
#5	1-15/32"	3-3/4"	1/2"
#6	1-3/4"	4"	5/8"
#7	2"	4-3/8"	5/8"
#8	2-1/2"	4-3/4"	3/4"

HSS DIN335 COUNTERSINK BITS EUROPE TYPE



For thread	D	L1	d
1-4	6.35	45	6.35
2-5	10.00	45	8.00
5-10	14.00	48	8.00
10-15	21.00	65	10.00
15-20	28.00	85	12.00
20-25	35.00	102	15.00
25-30	44.00	115	15.00
30-35	48.00	127	15.00
35-40	53.00	136	15.00
40-50	64.00	166	18.00

DRILLING TOOLS

HSS SINGLEFLUTE COUNTERSINK BITS



For thread	D	L1	d
3/16"	3/4"	1-1/2"	3/16"
1/4"	3/4"	2"	1/4"
5/16"	1"	2"	1/4"
3/8"	1"	2"	1/4"
5/2"	1"	2"	1/4"
5/8"	1-1/8"	2-3/4"	3/8"
5/8"	1-1/8"	2-3/4"	1/2"
3/4"	1-5/16"	2-3/4"	3/8"
3/4"	1-5/16"	2-3/4"	1/2"
7/8"	1-5/16"	2-3/4"	1/2"
1"	1-5/16"	2-3/4"	1/2"
1-1/4"	1-5/8"	3-3/8"	3/4"
1-1/2"	1-5/8"	3-1/2"	3/4"
2"	1-5/8"	3-3/4"	3/4"

HSS DIN335 COUNTERSINK BITS

D	L1	d
4.3	40.0	4.0
4.8	40.0	4.0
5.0	40.0	4.0
5.3	40.0	4.0
5.8	45.0	5.0
6.0	45.0	5.0
6.3	45.0	5.0
7.0	50.0	6.0
7.3	50.0	6.0
8.0	50.0	6.0
8.3	50.0	6.0
9.4	50.0	6.0
10.0	50.0	6.0
10.1	50.0	6.0
11.5	56.0	8.0
12.4	56.0	8.0
13.4	56.0	8.0
15.0	60.0	10.0
16.5	60.0	10.0
16.5	60.0	10.0
19.0	63.0	10.0
20.5	63.0	10.0
23.0	67.0	10.0
25.0	67.0	10.0
26.0	71.0	12.0
28.0	71.0	12.0
30.0	71.0	12.0
31.0	71.0	12.0
37.0	90.0	12.0
40.0	90.0	15.0



HSS DRILL BIT

ASME B.94.11M---Jobber length



D	D	L2	L1
1/16	.0625	7/8	1-7/8
5/64	.0781	1	2
3/32	.0938	1-1/4	2-1/4
7/64	.1094	1-1/2	2-5/8
1/8	.1250	1-5/8	2-3/4
9/64	.1406	1-3/4	2-7/8
5/32	.2188	2	3-1/8
11/64	.1719	2-1/8	3-1/4
3/16	.1875	2-5/16	3-1/2
13/64	.2031	2-7/16	3-5/8
7/32	.2188	2-1/2	3-3/4
15/64	.2344	2-5/8	3-3/7
1/4	.2500	2-3/4	4
17/64	.2656	2-7/8	4-1/8
9/32	.2812	2-15/16	4-1/4
19/64	.2969	3-1/16	4-3/8
5/16	.3125	3-3/16	4-1/2
21/64	.3281	3-5/16	4-3/4
11/32	.3438	3-7/16	4-5/8
23/64	.3594	3-1/2	4-7/8
3/8	.3750	3-5/8	5
25/64	.3906	3-3/4	5-1/8
13/32	.4062	3-7/8	5-1/4
27/64	.4219	3-15/16	5-3/8
7/16	.4375	4-1/16	5-1/2
29/64	.4531	4-3/16	5-5/8
15/32	.4688	4-5/16	5-3/4
31/64	.4844	4-3/8	5-7/8
1/2	.5000	4-1/2	6
#1	.2280	2-5/8	3-7/8
#2	.2210	2-5/8	3-7/8
#3	.2130	2-1/2	3-3/4
#4	.2090	2-1/2	3-3/4
#5	.2055	2-1/2	3-3/4
#6	.2040	2-1/2	3-3/4
#7	.2010	2-7/16	3-5/8
#8	.1990	2-7/16	3-5/8
#9	.1960	2-7/16	3-5/8
#10	.1935	2-7/16	3-5/8
#11	.1910	2-5/16	3-1/2
#12	.1890	2-5/16	3-1/2
#13	.1850	2-5/16	3-1/2
#14	.1820	2-3/16	3-3/8
#15	.1800	2-3/16	3-3/8
#16	.1770	2-3/16	3-3/8
#17	.1730	2-3/16	3-3/8
#18	.1695	2-1/8	3-1/4
#19	.1660	2-1/8	3-1/4
#20	.1610	2-1/8	3-1/4
#21	.1590	2-1/8	3-1/4
#22	.1570	2	3-1/8
#23	.1540	2	3-1/8
#24	.1520	2	3-1/8
#25	.1495	1-7/8	3
#26	.1470	1-7/8	3
#27	.1440	1-7/8	3
#28	.1405	1-3/4	2-7/8
#29	.1360	1-3/4	2-7/8
#30	.1285	1-5/8	2-3/4
#31	.1200	1-5/8	2-3/4
#32	.1160	1-5/8	2-3/4
#33	.1130	1-1/2	2-5/8

D	D	L2	L1
#34	.1110	1-1/2	2-5/8
#35	.1100	1-1/2	2-5/8
#36	.1065	1-7/16	2-1/2
#37	.1040	1-7/16	2-1/2
#38	.1015	1-7/16	2-1/2
#39	.0995	1-3/8	2-3/8
#40	.0980	1-3/8	2-3/8
#41	.0960	1-3/8	2-3/8
#42	.0935	1-1/4	2-1/4
#43	.0890	1-1/4	2-1/4
#44	.0860	1-1/8	2-1/8
#45	.0820	1-1/8	2-1/8
#46	.0810	1-1/8	2-1/8
#47	.0785	1	2
#48	.0760	1	2
#49	.0730	1	2
#50	.0700	1	2
#51	.0670	1	2
#52	.0635	7/8	1-7/8
#53	.0595	7/8	1-7/8
#54	.0550	7/8	1-7/8
#55	.0520	7/8	1-7/8
#56	.0465	3/4	1-3/4
#57	.0430	3/4	1-3/4
#58	.0420	11/16	1-5/8
#59	.0410	11/16	1-5/8
#60	.0400	11/16	1-5/8
A	.2340	2-5/8	3-7/8
B	.2380	2-3/4	4
C	.2420	2-3/4	4
D	.2460	2-3/4	4
E	.2500	2-3/4	4
F	.2570	2-7/8	4-1/8
G	.2610	2-7/8	4-1/8
H	.2660	2-7/8	4-1/8
I	.2720	2-7/8	4-1/8
J	.2770	2-7/8	4-1/8
K	.2810	2-15/16	4-1/4
L	.2900	2-15/16	4-1/4
M	.2950	3-1/16	4-3/8
N	.3020	3-1/16	4-3/8
O	.3160	3-3/16	4-1/2
P	.3230	3-5/16	4-5/8
Q	.3320	3-7/16	4-3/4
R	.3390	3-7/16	4-3/4
S	.3480	3-1/2	4-7/8
T	.3580	3-1/2	4-7/8
U	.3680	3-5/8	5
V	.3770	3-5/8	5
W	.3860	3-3/4	5-1/8
X	.3970	3-3/4	5-1/8
Y	.4040	3-7/8	5-1/4
Z	.4130	3-7/8	5-1/4

D	D	L2	L1
1.00mm	.0394	17	41
1.50mm	.0591	22	48
2.00mm	.0787	25	51
2.50mm	.0984	35	60
3.00mm	.1181	41	70
3.30mm	.1299	44	73
3.50mm	.1378	44	73
4.00mm	.1575	54	83
4.20mm	.1654	54	83
4.50mm	.1772	56	86
5.00mm	.1969	62	92
5.50mm	.2165	64	95
6.00mm	.2362	70	102
6.50mm	.2559	73	105
7.00mm	.2756	73	105
7.50mm	.2953	78	111
8.00mm	.3150	81	114
8.50mm	.3346	87	121
9.00mm	.3543	89	124
9.50mm	.3740	92	127
10.00mm	.3937	95	130
10.50mm	.4134	98	133
11.00mm	.4331	103	140
11.50mm	.4528	106	143
12.00mm	.4724	111	149
12.50mm	.4921	114	152
13.00mm	.5118	114	152

*Metric sizes to ANSI specifications



ASME B.94.11M---Jobber length

D	D	L2	L1
25/64	.3906	3-3/4	5-1/8
13/32	.4062	3-7/8	5-1/4
27/64	.4219	3-15/16	5-3/8
7/16	.4375	4-1/6	5-1/2
29/64	.4531	4-3/16	5-5/8
15/32	.4688	4-5/16	5-3/4
31/64	.4844	4-3/8	5-7/8
1/2	.5000	4-1/2	6

*3/8" Reduced Shank

HSS DRILL BIT

ASME B.94.11M-screw machine length

D	D	L2	L1
3/64	.0469	1/2	1-3/8
1/16	.0625	5/8	1-5/8
5/64	.0781	11/16	1-11/16
3/32	.0938	3/4	1-3/4
7/64	.1094	13/16	1-13/16
1/8	.1250	7/8	1-7/8
9/64	.1406	15/16	1-15/16
5/32	.1562	1	2-1/16
11/64	.1719	1-1/16	2-1/8
3/16	.1875	1-1/8	2-3/16
13/64	.2031	1-3/16	3-1/4
7/32	.2188	1-1/4	2-3/8
15/64	.2344	1-5/16	2-7/16
1/4	.2500	1-3/8	2-1/2
17/64	.2656	1-7/16	2-5/8
9/32	.2812	1-1/2	2-11/16
19/64	.2969	1-9/16	2-3/4
5/16	.3125	1-5/8	2-13/16
21/64	.3281	1-11/16	2-15/16
11/32	.3438	1-11/16	3
23/64	.3594	1-3/4	3-1/16
3/8	.3750	1-13/16	3-1/8
25/64	.3906	1-7/8	3-1/4
13/32	.4062	1-15/16	3-5/16
27/64	.4219	2	3-3/8
7/16	.4375	2-1/16	3-7/16
29/64	.4531	2-1/8	3-9/16
15/32	.4688	2-1/8	3-5/8
31/64	.4844	2-3/16	3-11/16
1/2	.5000	2-1/4	3-3/4
#1	.2280	1-5/16	2-7/16
#2	.2210	1-5/16	2-7/16
#3	.2130	1-1/4	2-3/8
#4	.2090	1-1/4	2-3/8
#5	.2055	1-1/4	2-3/8
#6	.2040	1-1/4	2-3/8
#7	.2010	1-3/16	2-1/4
#8	.1990	1-3/16	2-1/4
#9	.1960	1-3/16	2-1/4
#10	.1935	1-3/16	2-1/4
#11	.1910	1-3/16	2-1/4
#12	.1890	1-3/16	2-1/4
#13	.1850	1-1/8	2-3/16
#14	.1820	1-1/8	2-3/16
#15	.1800	1-1/8	2-3/16
#16	.1770	1-1/8	2-3/16
#17	.1730	1-1/8	2-3/16
#18	.1695	1-1/16	2-1/8
#19	.1660	1-1/16	2-1/8
#20	.1610	1-1/16	2-1/8
#21	.1590	1-1/16	2-1/8
#22	.1570	1-1/16	2-1/8
#23	.1540	1	2-1/16
#24	.1520	1	2-1/16
#25	.1495	1	2-1/16
#26	.1470	1	2-1/16
#27	.1440	1	2-1/16
#28	.1405	15/16	1-15/16
#29	.1360	15/16	1-15/16
#30	.1285	15/16	1-15/16
#31	.1200	7/8	1-7/8
#32	.1160	7/8	1-7/8



D D L2 L1

#	D	L2	L1
#33	.1130	7/8	1-7/8
#34	.1110	7/8	1-7/8
#35	.1100	7/8	1-7/8
#36	.1065	13/16	1-13/16
#37	.1040	13/16	1-13/16
#38	.1015	13/16	1-13/16
#39	.0995	13/16	1-13/16
#40	.0980	13/16	1-13/16
#41	.0960	13/16	1-13/16
#42	.0935	3/4	1-3/4
#43	.0890	3/4	1-3/4
#44	.8660	3/4	1-3/4
#45	.0820	3/4	1-3/4
#46	.0810	3/4	1-3/4
#47	.0785	11/16	1-11/16
#48	.0760	11/16	1-11/16
#49	.0730	11/16	1-11/16
#50	.0700	11/16	1-11/16
#51	.0670	11/16	1-11/16
#52	.0635	11/16	1-11/16
#53	.0595	5/8	1-5/8
#54	.0550	5/8	1-5/8
#55	.0520	5/8	1-5/8
#56	.0465	1/2	1-3/8
#57	.0430	1/2	1-3/8
#58	.0420	1/2	1-3/8
#59	.0410	1/2	1-3/8
#60	.0400	1/2	1-3/8
A	.2340	1-15/16	2-7/16
B	.2380	1-3/8	2-1/2
C	.2420	1-3/8	2-1/2
D	.2460	1-3/8	2-1/2
E	.2500	1-3/8	2-1/2
F	.2570	1-7/16	2-5/8
G	.2610	1-7/16	2-5/8
H	.2660	1-1/2	2-11/16
I	.2720	1-1/2	2-11/16
J	.2770	1-1/2	2-11/16
K	.2810	1-1/2	2-11/16
L	.2900	1-9/16	2-3/4
M	.2950	1-9/16	2-3/4
N	.3020	1-5/8	2-13/16
O	.3160	1-11/16	2-15/16
P	.3230	1-11/16	2-15/16
Q	.3320	1-11/16	3
R	.3390	1-11/16	3
S	.3480	1-3/4	3-1/16
T	.3580	1-3/4	3-1/16
U	.3680	1-13/16	3-3/8
V	.3770	1-7/8	3-1/4
W	.3860	1-7/8	3-1/4
X	.3970	1-15/16	3-15/16
Y	.4040	1-15/16	3-15/16
Z	.4130	2	3-3/8

ASME B.94.11M---taper length

D	D	L2	L1
1/64	.0156	5/16	1-1/2
1/32	.0312	3/4	2
3/64	.0469	1-1/8	2-1/4
1/16	.0625	1-3/4	3
5/64	.0781	2	3-3/4
3/32	.0938	2-1/4	4-1/4
7/64	.1094	2-1/2	4-5/8
1/8	.1250	2-3/4	5-1/8
9/64	.1406	3	5-3/8
5/32	.1562	3	5-3/8
11/64	.1719	3-3/8	5-3/4
3/16	.1875	3-3/8	5-3/4
13/64	.2031	3-5/8	6
7/32	.2188	3-5/8	6
15/64	.2344	3-3/4	6-1/8
1/4	.2500	3-3/4	6-1/8
17/64	.2656	3-7/8	6-1/4
9/32	.2812	3-7/8	6-1/4
19/64	.2969	4	6-3/8
5/16	.3125	4	6-3/8
21/64	.3281	4-1/8	6-1/2
11/32	.3438	4-1/8	6-1/2
23/64	.3594	4-1/4	6-3/4
3/8	.3750	4-1/4	6-3/4
25/64	.3906	4-3/8	7
13/32	.4062	4-3/8	7
27/64	.4219	4-5/8	7-1/4
7/16	.4375	4-5/8	7-1/4
29/64	.4531	4-3/4	7-1/2
15/32	.4688	4-3/4	7-1/2
31/64	.4844	4-3/4	7-3/4
1/2	.5000	4-3/4	7-3/4
#1	.2280	3-3/4	6-1/8
#2	.2210	3-3/4	6-1/8
#3	.2130	3-5/8	6
#4	.2090	3-5/8	6
#5	.2055	3-5/8	6
#6	.2040	3-5/8	6
#7	.2010	3-5/8	6
#8	.1990	3-5/8	6
#9	.1960	3-5/8	6
#10	.1935	3-5/8	6
#11	.1910	3-5/8	6
#12	.1890	3-5/8	6
#13	.1850	3-3/8	5-3/4
#14	.1820	3-3/8	5-3/4
#15	.1800	3-3/8	5-3/4
#16	.1770	3-3/8	5-3/4
#17	.1730	3-3/8	5-3/4
#18	.1695	3-3/8	5-3/4
#19	.1660	3-3/8	5-3/4
#20	.1610	3-3/8	5-3/4
#21	.1590	3-3/8	5-3/4
#22	.1570	3-3/8	5-3/4
#23	.1540	3	5-3/8
#24	.1520	3	5-3/8
#25	.1495	3	5-3/8
#26	.1470	3	5-3/8
#27	.1440	3	5-3/8
#28	.1405	3	5-3/8
#29	.1360	3	5-3/8
#30	.1285	3	5-3/8

DRILLING TOOLS

DRILLING TOOLS

HSS DRILL BIT



ASME B.94.11M-taper length

D	D	L2	L1
#31	.1200	2-3/4	5-1/8
#32	.1160	2-3/4	5-1/8
#33	.1130	2-3/4	5-1/8
#34	.1110	2-3/4	5-1/8
#35	.1100	2-3/4	5-1/8
#36	.1065	2-1/2	4-5/8
#37	.1040	2-1/2	4-5/8
#38	.1015	2-1/2	4-5/8
#39	.0995	2-1/2	4-5/8
#40	.0980	2-1/2	4-5/8
#41	.0960	2-1/2	4-5/8
#42	.0935	2-1/4	4-1/4
#43	.0890	2-1/4	4-1/4
#44	.0860	2-1/4	4-1/4
#45	.0820	2-1/4	4-1/4
#46	.0810	2-1/4	4-1/4
#47	.0785	2-1/4	4-1/4
#48	.0760	2	3-3/4
#49	.0730	2	3-3/4
#50	.0700	2	3-3/4
#51	.0670	2	3-3/4
#52	.0635	2	3-3/4
#53	.0595	1-3/4	3
#54	.0550	1-3/4	3
#55	.0520	1-3/4	3
#56	.0465	1-1/8	2-1/4
#57	.0430	1-1/8	2-1/4
#58	.0420	1-1/8	2-1/4
#59	.0410	1-1/8	2-1/4
#60	.0400	1-1/8	2-1/4
A	.2340	3-3/4	6-1/8
B	.2380	3-3/4	6-1/8
C	.2420	3-3/4	6-1/8
D	.2460	3-3/4	6-1/8
E	.2500	3-3/4	6-1/8
F	.2570	3-7/8	6-1/4
G	.2610	3-7/8	6-1/4
H	.2660	3-7/8	6-1/4
I	.2720	3-7/8	6-1/4
J	.2770	3-7/8	6-1/4
K	.2810	3-7/8	6-1/4
L	.2900	4	6-3/8
M	.2950	4	6-3/8
N	.3020	4	6-3/8
O	.3160	4-1/8	6-1/2
P	.3230	4-1/8	6-1/2
Q	.3320	4-1/8	6-1/2
R	.3390	4-1/8	6-1/2
S	.3480	4-1/4	6-3/4
T	.3580	4-1/4	6-3/4
U	.3680	4-1/4	6-3/4
V	.3770	4-3/8	7
W	.3860	4-3/8	7
X	.3970	4-3/8	7
Y	.4040	4-3/8	7
Z	.4130	4-5/8	7-1/4



ASME B.94 11M-6" aircraft extension

D	D	L2	L1
1/16	.0625	7/8	6
5/64	.0781	1	6
3/32	.0938	1-1/4	6
7/64	.1094	1-1/2	6
1/8	.1250	1-5/8	6
9/64	.1406	1-3/4	6
5/32	.1562	2	6
11/64	.1719	2-1/8	6
3/16	.1875	2-5/16	6
13/64	.2031	2-7/16	6
7/32	.2188	2-1/2	6
15/64	.2344	2-5/8	6
1/4	.2500	2-3/4	6
17/64	.2656	2-7/8	6
9/32	.2812	2-15/16	6
19/64	.2969	3-1/16	6
5/16	.3125	3-3/16	6
21/64	.3281	3-5/16	6
11/32	.3438	3-7/16	6
23/64	.3594	3-1/2	6
3/8	.3750	3-5/8	6
7/16	.4375	4-1/16	6
1/2	.5000	4-1/2	6

ASME B.94 11M-12" aircraft extension

D	D	L2	L1
1/16	.0625	7/8	12
5/64	.0781	1	12
3/32	.0938	1-1/4	12
7/64	.1094	1-1/2	12
1/8	.1250	1-5/8	12
9/64	.1406	1-3/4	12
5/32	.1562	2	12
11/64	.1719	2-1/8	12
3/16	.1875	2-5/16	12
13/64	.2031	2-7/16	12
7/32	.2188	2-1/2	12
15/64	.2344	2-5/8	12
1/4	.2500	2-3/4	12
17/64	.2656	2-7/8	12
9/32	.2812	2-15/16	12
19/64	.2969	3-1/16	12
5/16	.3125	3-3/16	12
21/64	.3281	3-5/16	12
11/32	.3438	3-7/16	12
23/64	.3594	3-1/2	12
3/8	.3750	3-5/8	12
7/16	.4375	4-1/16	12
1/2	.5000	4-1/2	12



1/2" Shank, Silver & Deming

D	D	L2	L1
33/64	.5156	3	6
17/32	.5312	3	6
35/64	.5469	3	6
9/16	.5625	3	6
37/64	.5781	3	6
19/32	.5938	3	6
39/64	.6094	3	6
5/8	.6250	3	6
41/64	.6406	3	6
21/32	.6562	3	6
43/64	.6719	3	6
11/16	.6875	3	6
45/64	.7031	3	6
23/32	.7188	3	6
47/64	.7344	3	6
3/4	.7500	3	6
49/64	.7656	3	6
23/32	.7812	3	6
51/64	.7969	3	6
13/16	.8125	3	6
53/64	.8281	3	6
27/32	.8438	3	6
55/64	.8594	3	6
7/8	.8750	3	6
57/64	.8906	3	6
29/32	.9062	3	6
59/64	.9219	3	6
15/16	.9375	3	6
61/64	.9531	3	6
31/32	.9688	3	6
63/64	.9844	3	6
1	1.0000	3	6
1-1/32	1.0312	3	6
1-1/16	1.0625	3	6
1-3/32	1.0938	3	6
1-1/8	1.1250	3	6
1-5/32	1.1562	3	6
1-3/16	1.1875	3	6
1-7/32	1.2188	3	6
1-1/4	1.2500	3	6
1-5/16	1.3125	3	6
1-3/8	1.3750	3	6
1-7/16	1.4375	3	6
1-1/2	1.5000	3	6

12", 18" extra long

D	D	L2	L1
1/4	.2500	9/13	12/18
5/16	.3125	9/13	12/18
3/8	.3750	9/13	12/18
7/16	.4375	9/13	12/18
1/2	.5000	9/13	12/18
9/16	.5625	9/13	12/18
5/8	.6250	9/13	12/18

DRILLING TOOLS

DRILLING TOOLS

HSS DRILL BIT

ANSI Standard Taper Shank Drill

D	D	L2	L1	MTNO.
1/8	.1250	1-7/8	5-1/8	1
9/64	.1406	2-1/8	5-3/8	1
5/32	.1562	2-1/8	5-3/8	1
11/64	.1719	2-1/2	5-3/4	1
3/16	.1875	2-1/2	5-3/4	1
13/64	.2031	2-3/4	6	1
7/32	.2188	2-3/4	6	1
15/64	.2344	2-7/8	6-1/8	1
1/4	.2500	2-7/8	6-1/8	1
17/64	.2656	3	6-1/4	1
9/32	.2812	3	6-1/4	1
19/64	.2969	3-1/8	6-3/8	1
5/16	.3125	3-1/8	6-3/8	1
21/64	.3281	3-1/4	6-1/2	1
11/32	.3438	3-1/4	6-1/2	1
23/64	.3594	3-1/2	6-3/4	1
3/8	.3750	3-1/2	6-3/4	1
25/64	.3906	3-5/8	7	1
13/32	.4062	3-5/8	7	1
27/64	.4219	3-7/8	7-1/4	1
7/16	.4375	3-7/8	7-1/4	1
29/64	.4531	4-1/8	7-1/2	1
15/32	.4688	4-1/8	7-1/2	1
31/64	.4844	4-3/8	8-1/4	2
1/2	.5000	4-3/8	8-1/4	2
33/64	.5156	4-5/8	8-1/2	2
17/32	.5312	4-5/8	8-1/2	2
35/64	.5469	4-7/8	8-3/4	2
9/16	.5625	4-7/8	8-3/4	2
37/64	.5781	4-7/8	8-3/4	2
19/32	.5938	4-7/8	8-3/4	2
39/64	.6094	4-7/8	8-3/4	2
5/8	.6250	4-7/8	8-3/4	2
41/64	.6406	5-1/8	9	2
21/32	.6562	5-1/8	9	2
43/64	.6719	5-3/8	9-1/4	2
11/16	.6875	5-3/8	9-1/4	2
45/64	.7031	5-5/8	9-1/2	2
23/32	.7188	5-5/8	9-1/2	2
47/64	.7344	5-7/8	9-3/4	2
3/4	.7500	5-7/8	9-3/4	2
49/64	.7656	6	9-7/8	2
25/32	.7812	6	9-7/8	2
51/64	.7969	6-1/8	10-3/4	3
13/16	.8125	6-1/8	10-3/4	3
53/64	.8281	6-1/8	10-3/4	3
27/32	.8438	6-1/8	10-3/4	3
55/64	.8594	6-1/8	10-3/4	3
7/8	.8750	6-1/8	10-3/4	3
57/64	.8906	6-1/8	10-3/4	3
29/32	.9062	6-1/8	10-3/4	3
59/64	.9219	6-1/8	10-3/4	3
15/16	.9375	6-1/8	10-3/4	3
61/64	.9531	6-3/8	11	3
31/32	.9688	6-3/8	11	3
63/64	.9844	6-3/8	11	3
1	1.0000	6-3/8	11	3
1-1/64	1.0156	6-1/2	11-1/8	3
1-1/32	1.0312	6-1/2	11-1/8	3
1-3/64	1.0469	6-5/8	11-1/4	3
1-1/16	1.0625	6-5/8	11-1/4	3
1-5/64	1.0781	6-7/8	12-1/2	4



ANSI Standard Taper Shank Drill

D	D	L2	L1	MTNO.
1-3/32	1.0938	6-7/8	12-1/2	4
1-7/64	1.1094	7-1/8	12-3/4	4
1-1/8	1.1250	7-1/8	12-3/4	4
1-9/64	1.1406	7-1/4	12-7/8	4
1-5/32	1.1562	7-1/4	12-7/8	4
1-11/64	1.1719	7-3/8	13	4
1-3/16	1.1875	7-3/8	13	4
1-13/64	1.2031	7-1/2	13-1/8	4
1-7/32	1.2188	7-1/2	13-1/8	4
1-15/64	1.2344	7-7/8	13-1/2	4
1-1/4	1.2500	7-7/8	13-1/2	4
1-17/64	1.2656	8-1/2	14-1/8	4
1-9/32	1.2812	8-1/2	14-1/8	4
1-19/64	1.2965	8-5/8	14-1/4	4
1-5/16	1.3125	8-5/8	14-1/4	4
1-21/64	1.3281	8-3/4	14-3/8	4
1-11/32	1.3438	8-3/4	14-3/8	4
1-23/64	1.3594	8-7/8	14-1/2	4
1-3/8	1.3750	8-7/8	14-1/2	4
1-25/64	1.3906	9	14-5/8	4
1-13/32	1.4062	9	14-5/8	4
1-27/64	1.4219	9-1/8	14-3/4	4
1-7/16	1.4375	9-1/8	14-3/4	4
1-29/64	1.4531	9-1/4	14-7/8	4
1-15/32	1.4688	9-1/4	14-7/8	4
1-31/64	1.4844	9-3/8	15	4
1-1/2	1.5000	9-3/8	15	4
1-17/32	1.5312	9-3/8	16-3/8	5
1-9/16	1.5625	9-5/8	16-5/8	5
1-19/32	1.5938	9-7/8	16-7/8	5
1-5/8	1.6250	10	17	5
1-21/32	1.6562	10-1/8	17-1/8	5
1-11/16	1.6875	10-1/8	17-1/8	5
1-23/32	1.7188	10-1/8	17-1/8	5
1-3/4	1.7500	10-1/8	17-1/8	5
1-25/32	1.7812	10-1/8	17-1/8	5
1-13/16	1.8125	10-1/8	17-1/8	5
1-27/32	1.8438	10-1/8	17-1/8	5
1-7/8	1.8750	10-3/8	17-3/8	5
1-29/32	1.9062	10-3/8	17-3/8	5
1-15/16	1.9375	10-3/8	17-3/8	5
1-31/32	1.9688	10-3/8	17-3/8	5
2	2.0000	10-3/8	17-3/8	5
2-1/32	2.0312	10-3/8	17-3/8	5
2-1/16	2.0625	10-1/4	17-3/8	5
2-3/32	2.0938	10-1/4	17-3/8	5
2-1/8	2.1250	10-1/4	17-3/8	5
2-5/32	2.1562	10-1/4	17-3/8	5
2-3/16	2.1875	10-1/4	17-3/8	5
2-7/32	2.2188	10-1/8	17-3/8	5
2-1/4	2.2500	10-1/8	17-3/8	5
2-5/16	2.3125	10-1/8	17-3/8	5
2-3/8	2.3750	10-1/8	17-3/8	5
2-7/16	2.4375	11-1/4	18-3/4	5
2-1/2	2.5000	11-1/4	18-3/4	5
2-9/16	2.5625	11-7/8	19-1/2	5
2-5/8	2.6250	11-7/8	19-1/2	5
2-11/16	2.6875	12-3/4	20-3/8	5
2-3/4	2.7500	12-3/4	20-3/8	5
2-13/16	2.8125	13-3/8	21-1/8	5
2-7/8	2.8750	13-3/8	21-1/8	5
2-15/16	2.9375	14	21-3/4	5
3	3.0000	14	21-3/4	5

DRILLING TOOLS

DRILLING TOOLS

STEP DRILL-DOUBLE STRAIGHT FLUTS



DRILLING TOOLS

DRILLING TOOLS

Point cut: Split point DIN1412C			
Point angle: 118 Degrees			
Step angle: 90 Derees			
Surface: Bright / Tin coated / Black / Tiala			
1-1).Metric step drill			
Drilling range/MM	Total length	Steps	Shank
3-12	65	10	6
3-14	65	13	6
4-12	65	5	6
4-12	65	9	6
4-20	75	9	8
4-22	72	10	8
4-24	76	11	8
4-30	100	14	10
4-32	89	15	10
4-39	107	13	10
5-35	78	13	13
6-18	70	7	8
6-20	72	8	8
6-30	93	13	10
6-35	78	13	13
6-36	86	10	12
6-38	100	12	10
10-20	77	11	9
14-24	78	6	10
20-30	82	11	12
Other size are available			

1-2).ANSI step drill		
Drilling range/MM	Total length	Shank
1/8"-1/2"	7	1/4"
1/8"-1/2"	13	1/4"
1/8"-3/8"	5	1/4"
1/4"-3/4"	9	3/8"
1/4"-7/8"	11	3/8"
1/4"-1-3/8"	10	3/8"
3/16"-1/2"	6	1/4"
3/16"-9/16"	7	1/4"
3/16"-7/8"	12	3/8"
9/16"-1"	8	3/8"
13/16"-1/3/8"	10	1/2"
Other size are available		

STEP DRILL-DOUBLE SPIRAL FLUTS



HSS
Bright

HSS
TIN

HSS
Hex

Point cut: Split point DIN1412C

Point angle: 118 Degrees

Step angle: 90 Derees

Surface: Bright / Tin coated / Black / Tiala

3-1).Metric step drill

Drilling range/MM	Total length	Steps	Shank
3-12	65	10	6
3-14	65	13	6
4-12	65	5	6
4-12	65	9	6
4-20	75	9	8
4-22	72	10	8
4-24	76	11	8
4-30	100	14	10
4-32	89	15	10
4-39	107	13	10
5-35	78	13	13
6-18	70	7	8
6-20	72	8	8
6-30	93	13	10
6-35	78	13	13
6-36	86	10	12
6-38	100	12	10
10-20	77	11	9
14-24	78	6	10
20-30	82	11	12

Other size are available

3-2).ANSI step drill

Drilling range / MM	Steps	Shank
1/8"-1/2"	7	1/4"
1/8"-1/2"	13	1/4"
1/8"-3/8"	5	1/4"
1/4"-3/4"	9	3/8"
1/4"-7/8"	11	3/8"
1/4"-1-3/8"	10	3/8"
3/16"-1/2"	6	1/4"
3/16"-9/16"	7	1/4"
3/16"-7/8"	12	3/8"
9/16"-1"	8	3/8"
13/16"-1-3/8"	10	1/2"

Other size are available

STEP DRILL SET

DRILLING TOOLS

DRILLING TOOLS

1. Step drill set

SIZES: MM

4-12, 4-20, 6-30

4-12, 4-20, 6-30

4-12, 4-20, 4-32

4-12, 4-20, 6-30

1/8"-1/2", 1/4"-3/4", 3/16"-7/8"

Other size are available

Metal case



2. Step drill set

SIZES: MM

3-12, 4-12, 6-20

3-14, 4-12, 6-20

4-12, 4-20, 4-30

4-12, 4-20, 6-30

4-12, 4-20, 4-32

4-12, 6-20, 4-30

4-12, 6-20, 6-30

3-12, 6-20, 4-24, 4-30

1/8"-1/2", 3/16"-1/2", 1/4"-3/4"

1/8"-1/2", 1/4"-3/4", 3/16"-7/8"

1/8"-1/2", 1/4"-3/4", 1/4"-7/8"

1/8"-1/2", 1/4"-3/4", 1/4"-7/8", 9/16"-1"

Other size are available

Plastic case



Aluminum case



3. Step drill set

SIZES: MM

3-12, 4-12, 6-20

3-14, 4-12, 6-20

4-12, 4-20, 4-30

4-12, 4-20, 6-30

4-12, 4-20, 4-32

4-12, 6-20, 4-30

4-12, 6-20, 6-30

3-12, 6-20, 4-24, 4-30

1/8"-1/2", 3/16"-1/2", 1/4"-3/4"

1/8"-1/2", 1/4"-3/4", 3/16"-7/8"

Other size are available

Blister bag



Wooden case



TUBE SHEET DRILL

DRILLING TOOLS

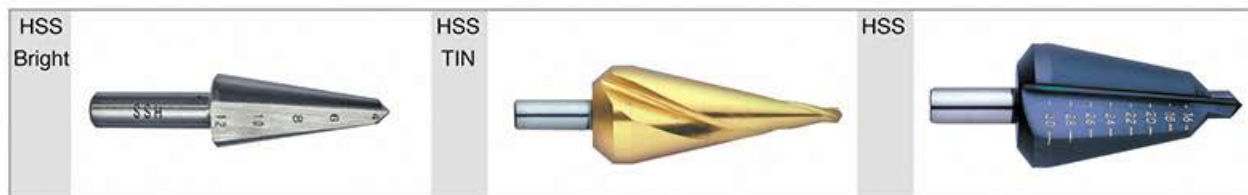

			High carbon steel	High carbon steel	High carbon steel	Cast iron	Cast iron	CuZn alloy brittle	CuZn alloy brittle	Aluminium alloy tough	Thermo plastic	Duro plastic
Sheet thickness	up to 4.0	up to 4.0	up to 4.0	up to 4.0	up to 4.0	up to 4.0	up to 4.0	up to 4.0	up to 4.0	up to 4.0	up to 4.0	up to 4.0
1VC=m/min	30	20	20	15	10	60	35	30	20	15		
Cooling lubricant	cutting spray	cutting spray	cutting spray	cutting spray	compressed air	compressed air	compressed air	compressed air	cutting spray	Water		compressed air
Drilling range/ MM	Total length	Shank	n=r.p.m	n=r.p.m	n=r.p.m	n=r.p.m	n=r.p.m	n=r.p.m	n=r.p.m	n=r.p.m	n=r.p.m	n=r.p.m
3-14	65	6	3185-682	2123-445	2123-445	1592-341	1062-227	6369-1365	3715-796	3185-682	2123-455	1592-341
8-20	65	8	1911-478	1274-318	1274-318	955-239	637-159	3822-955	2229-557	1911-478	1274-318	955-239
16-30.5	65	9	597-313	398-209	398-209	299-157	199-104	1194-627	697-365	597-313	398-209	299-157
24-40	75	10	398-239	265-159	265-159	199-157	133-80	796-478	464-279	398-239	265-159	199-119
36-50	72	12	265-191	177-127	177-127	133-96	88-64	531-382	310-223	285-191	177-127	133-96
40-61	76	13	239-157	159-104	159-104	119-78	80-52	478-313	279-183	239-157	159-104	119-78
5-25.4	100	10	1911-376	1274-251	1274-251	955-188	637-125	3822-752	2229-439	1911-376	1274-251	955-188
4-31	89	9	1911-308	1274-205	1274-205	955-154	637-103	3822-616	2229-360	1911-308	1274-205	955-154
5-22.5	107	8	1911-425	1274-283	1274-283	955-212	637-142	3822-849	2229-495	1911425	1274-283	955-212

Other size set are available.

TUBE SHEET DRILL SET

SIZES: MM	Metal case
3-14,8-20,16-30.5	
Other size set and packing are available.	

DRILLING TOOLS

PACKAGING FOR TWIST DRILL

DRILLING TOOLS

DRILLING TOOLS

A



PVC bag
1.0-8.0 mm 10PCS/bag
8.5-13.0 mm 5PCS/bag

B



PVC bag/With hanging hole
1.0-8.0 mm 10PCS/bag
8.5-13.0 mm 5PCS/bag

C



Square tube with hook
1.0-9.5 mm 10PCS/tube
9.5-13.0 mm 5PCS/tube

D



Square tube
1.0-9.5 mm 10PCS/tube
9.6-13.0 mm 5PCS/tube

E



Paper bag
1.0-8.0 mm 10PCS/bag
8.5-13.0 mm 5PCS/bag

F



Blister card

G



Plastic case
1.0-8.0 mm 10PCS/plastic box
8.5-13.0 mm 5PCS/plastic box

H



①



③

Package for Twist Drill
Iner box :①White box
②Color box
Out carton /w pallet:③



②

HSS TWIST DRILLS SET

DRILLING TOOLS

DRILLING TOOLS

ECH501



5PCS TWIST DRILL SET
Size(mm):1.5,2.5,3,4,5mm

ECH502



5PCS TWIST DRILL SET
Size(mm):4,5,6,8,10mm

ECH601



6PCS TWIST DRILL SET
Size(mm):2,3,4,5,6,8mm

ECH801



8PCS TWIST DRILL SET
Size(mm):3,4,5,6,7,8,9,10mm

ECH802



8PCS TWIST DRILL SET
Size(mm):3-10 x 1mm

ECH803



8PCS TWIST DRILL SET
Size(mm):3-10 x 1mm

ECH1001



10PCS TWIST DRILL SET
Size(mm):1-10 x 1mm

ECH1301



13PCS TWIST DRILL SET
Size(mm):1.5-6.5 x 0.5+3.2+4.8mm

ECH1302

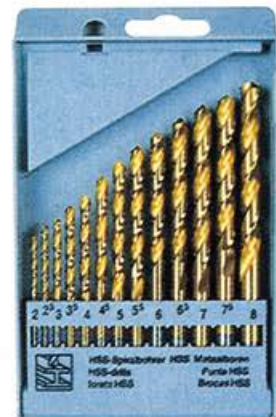

13PCS TWIST DRILL SET
Size(mm):2-8 x 0.5mm

HSS TWIST DRILLS SET

DRILLING TOOLS

DRILLING TOOLS

ECH1303

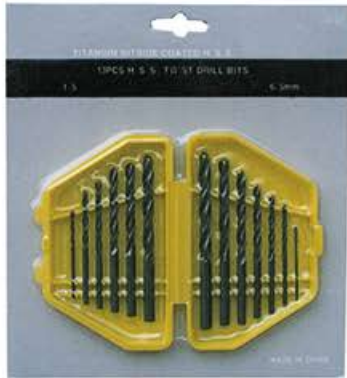

13PCS TWIST DRILL SET
Size(mm):1.5-6.5 × 0.5+3.2+4.8mm

ECH1304



13PCS TWIST DRILL SET
Size(mm):1.5-6.5 × 0.5+3.2+4.8mm

ECH1305



13PCS TWIST DRILL SET
Size(mm):1.5-6.5 × 0.5+3.2+4.8mm

ECH1306



13PCS TWIST DRILL SET
Size(mm):1.5-6.5 × 0.5+3.2+4.8mm

ECH1307



13PCS TWIST DRILL SET
Size(mm):1.5-6.5 × 0.5+3.2+4.8mm

ECH1308



13PCS TWIST DRILL SET
Size(mm):1/16-1/4 × 1/64inch

ECH1309



13PCS TWIST DRILL SET
Size(mm):1.5-6.5mm

ECH1901



19PCS TWIST DRILL SET
Size(mm):1.0-10.0 × 0.5mm

ECH1902

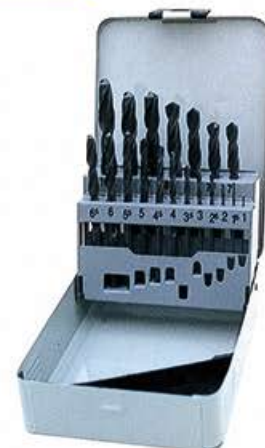

19PCS TWIST DRILL SET
Size(mm):1.0-10.0 × 0.5mm

HSS TWIST DRILLS SET

DRILLING TOOLS

DRILLING TOOLS

ECH1903



19PCS TWIST DRILL SET
Size(mm):1.0-7.0 × 0.5mm+8-13mm × 1mm

ECH1904



19PCS TWIST DRILL SET
Size(mm):1.0-10.0 × 0.5mm

ECH1905



19PCS TWIST DRILL SET
Size(mm):1.0-10.0 × 0.5mm

ECH1906



19PCS TWIST DRILL SET
Size(mm):1.0-10.0 × 0.5mm

ECH1907



19PCS TWIST DRILL SET
Size(mm):1.0-10.5 × 0.5mm

ECH1908



19PCS TWIST DRILL SET
Size(mm):1.0-10.0 × 0.5mm

ECH1909



19PCS TWIST DRILL SET
Size(mm):1.0-10.0 × 0.5mm

ECH1910



19PCS TWIST DRILL SET
Size(mm):1.0-10.0 × 0.5mm

ECH1911



19PCS TWIST DRILL SET
Size(mm):1.0-10.0 × 0.5mm

HSS TWIST DRILLS SET

DRILLING TOOLS

DRILLING TOOLS

ECH1912



19PCS TWIST DRILL SET
Size(mm):1.0-10.0 × 0.5mm

ECH1913



19PCS TWIST DRILL SET
Size(mm):1.0-10.0 × 0.5mm

ECH2101



21PCS TWIST DRILL SET
Size(inch):1/16-3/8 × 1/64inch

ECH2102



21PCS TWIST DRILL SET
Size(inch):1/16-3/8 × 1/64

ECH2103



21PCS TWIST DRILL SET
Size(inch):1/16-3/8 × 1/64

ECH2104



21PCS TWIST DRILL SET
Size(inch):1/16-3/8 × 1/64

ECH2105



21PCS TWIST DRILL SET
Size(inch):1/16-3/8 × 1/64

ECH2106



21PCS TWIST DRILL SET
Size(inch):1/16-3/8 × 1/64

ECH2501



25PCS TWIST DRILL SET
Size(mm):1.0-13.0 × 0.5mm

HSS TWIST DRILLS SET

DRILLING TOOLS

DRILLING TOOLS

ECH2502



25PCS TWIST DRILL SET
Size(mm):1.0-13.0 × 0.5mm

ECH2503



25PCS TWIST DRILL SET
Size(mm):1.0-13.0 × 0.5mm

ECH2504



25PCS TWIST DRILL SET
Size(mm):1.0-13.0 × 0.5mm

ECH2505



25PCS TWIST DRILL SET
Size(mm):1.0-13.0 × 0.5mm

ECH2506



25PCS TWIST DRILL SET
Size(mm):1.0-13.0 × 0.5mm

ECH2507



25PCS TWIST DRILL SET
Size(mm):1.0-13.0 × 0.5mm

ECH2508



25PCS TWIST DRILL SET
Size(mm):1.0-13.0 × 0.5mm

ECH2901



29PCS TWIST DRILL SET
Size(inch):1/16-1/2 × 1/64

ECH2902



29PCS TWIST DRILL SET
Size(inch):1/16-1/2 × 1/64

HSS TWIST DRILLS SET

DRILLING TOOLS

DRILLING TOOLS

ECH2903



29PCS TWIST DRILL SET
Size(inch):1/16-1/2 × 1/64

ECH2904



29PCS TWIST DRILL SET
Size(inch):1/16-1/2 × 1/64

ECH2905

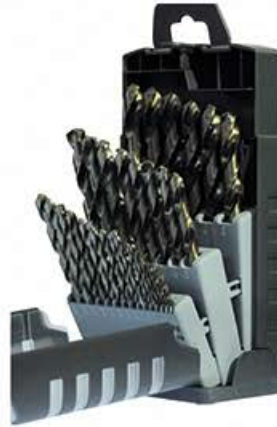

29PCS TWIST DRILL SET
Size(inch):1/16-1/2 × 1/64

ECH11501



115PCS TWIST DRILL SET
SPECIFICATION(mm):1#-60# A-3 1/16 -1/2x1/64

ECH11502



115PCS TWIST DRILL SET
SPECIFICATION(mm):1#-60# A-3 1/16 -1/2x1/64

ECH11503



115PCS TWIST DRILL SET
SPECIFICATION(mm):1#-60# A-3 1/16 -1/2x1/64

ECH102



ECH170



170PCS TWIST DRILL SET
Size(mm):1.0-8.0x0.5mmx10pcs
8.5-10.0x0.5x5pcs

ECH230



ECR801



8PCS REDUCE SHANK DRILL SET
SPECIFICATION(mm):9/16-1"by 16ths

ECT1001



10PCS TAPER SHANK DRILL SET
SIZE(mm):14-23x1mm in wooden case

ECT1002



10PCS TAPER SHANK DRILL SET
SIZE(mm):14-23x1mm in metal box

EUROCUT

DANYANG EUROCUT TOOLS CO., LTD



Fully Ground Drill Workshop



Blow molding machine

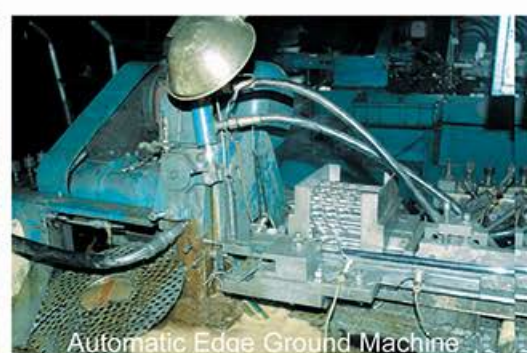

Automatic Edge Ground Machine



Packing Workshop



Fully Ground Drill Workshop

先进的生产设备是产品质量的重要保证。为保证最好的产品奉献给每一个客户，我们先后引进多台优良的产品设备。我们深信，籍着完善的管理、先进的设备和全体员工一丝不苟的工作态度，是优质品质的保证。

Advanced production equipment is the important guaranty to the product quality. In order to offer the customer the best product, we introduced excellent production equipment. We believe deeply that, lying on the perfect management, advanced equipment and earnest work of the staff, we may guarantee the best quality.



超凡品质 力求完美

每一个产品和技术创新都要经过系统的、严格的测试验证，以过到完美的品质。先进的检测设备是产品质量的重要保证，为保证最好的产品奉献给每一个客户，我们先后引进多台优良的检测设备。我们深信，藉着完善的管理，先进的设备的全体员工一丝不苟的工作态度，是优质品质的保证。

Every product and technical innovation need systematic and strict testing and verification, so as to reach the perfect quality. Advanced testing equipment is the important guaranty to the product quality, In order to offer the customer the best product, we introduced excellent testing equipment. We believe deeply that, lying on the perfect management, advanced equipment and earnest work of the staff, we may guarantee the best quality.

