

PRODUCTION TECHNICS

FULLY GROUND



HALF GROUND



ROLL FORGED



SURFACE FINISHING

BLACK



BRIGHT



DOUBLE COLOR



AMBER



RAINBOW



TIN COATED



STRAIGHT SHANK

DIN-338 HSS DRILL BIT

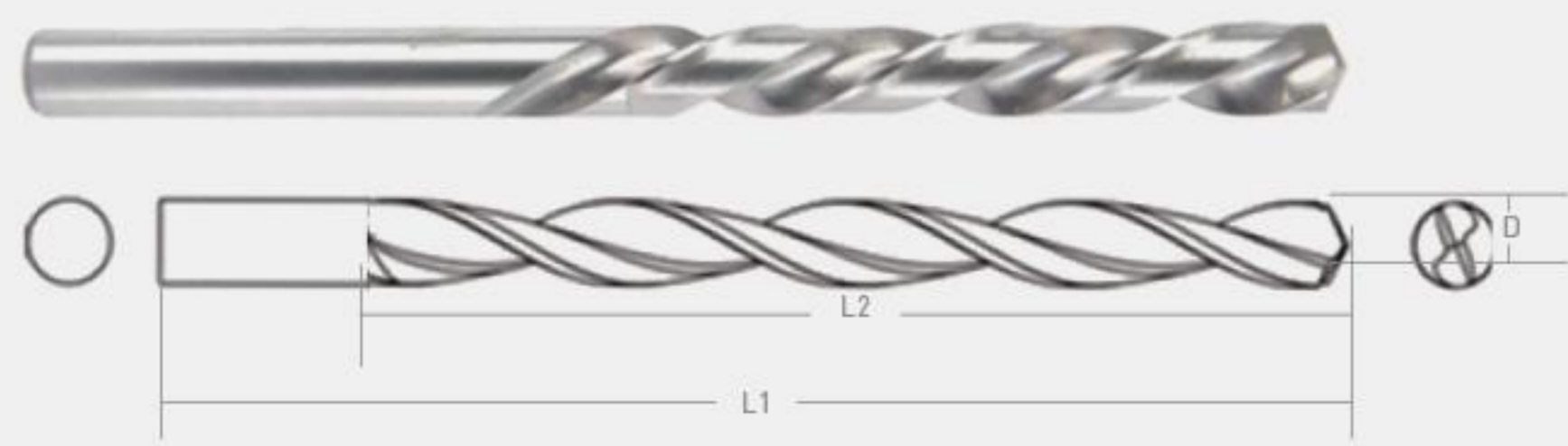
UNCOATED HIGH-SPEED STEEL
DRILL BIT

HSS COBALTSTAINLESS DRILL BIT

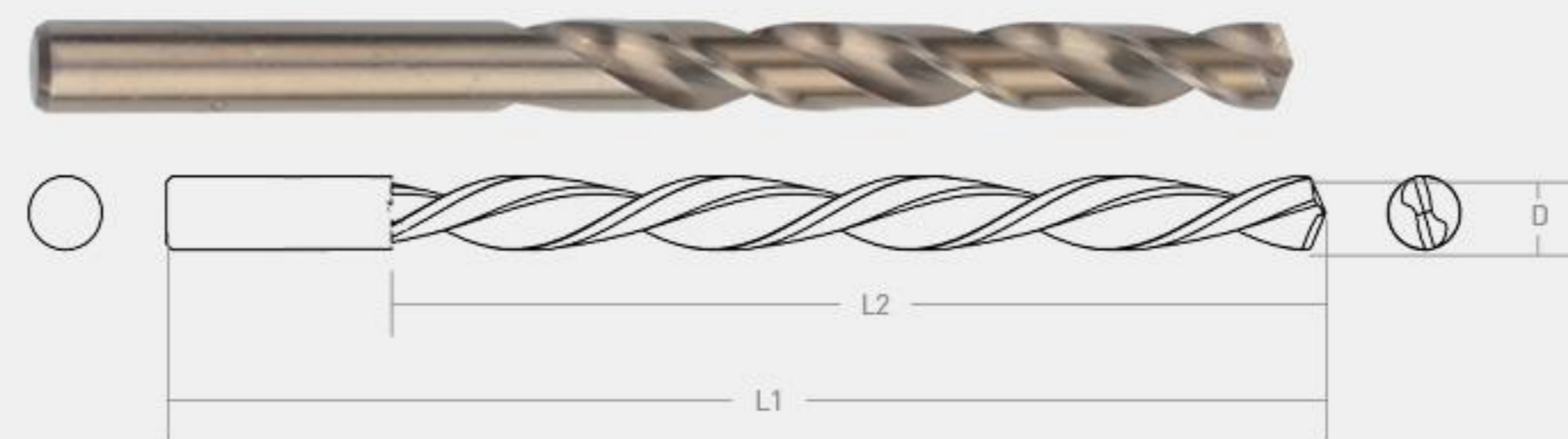
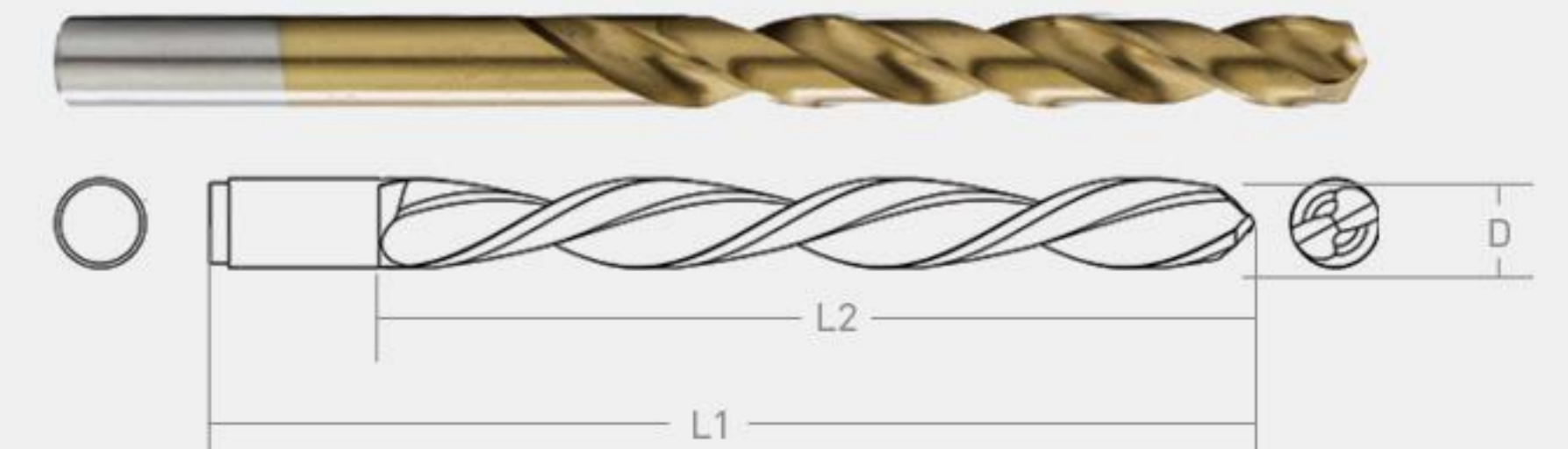
CHIP-CLEARING HIGH-SPEED
STEEL DRILL BIT

| Dia. | L2 | L1 | Dia. | L2 | L1 | Dia. | L2 | L1 | Dia. | L2 | L1 |
|------|----|----|------|----|-----|------|----|-----|------|-----|-----|
| 1 | 12 | 34 | 4.5 | 47 | 80 | 7.6 | 75 | 117 | 11.1 | 94 | 142 |
| 1.1 | 14 | 36 | 4.6 | 47 | 80 | 7.7 | 75 | 117 | 11.2 | 94 | 142 |
| 1.2 | 16 | 38 | 4.7 | 47 | 80 | 7.8 | 75 | 117 | 11.3 | 94 | 142 |
| 1.3 | 16 | 38 | 4.3 | 47 | 80 | 7.9 | 75 | 117 | 11.4 | 94 | 142 |
| 1.4 | 18 | 40 | 4.4 | 47 | 80 | 8 | 75 | 117 | 11.5 | 94 | 142 |
| 1.5 | 18 | 40 | 4.5 | 47 | 80 | 8.1 | 75 | 117 | 11.6 | 94 | 142 |
| 1.6 | 20 | 43 | 4.6 | 47 | 80 | 8.2 | 75 | 117 | 11.7 | 94 | 142 |
| 1.7 | 20 | 43 | 4.7 | 47 | 80 | 8.3 | 75 | 117 | 11.8 | 94 | 142 |
| 1.8 | 22 | 46 | 4.8 | 52 | 86 | 8.4 | 75 | 117 | 11.9 | 101 | 151 |
| 1.9 | 22 | 46 | 5 | 52 | 86 | 8.5 | 75 | 117 | 12 | 101 | 151 |
| 2 | 24 | 49 | 5.1 | 52 | 86 | 8.6 | 75 | 125 | 12.1 | 101 | 151 |
| 2.1 | 24 | 49 | 5.2 | 57 | 93 | 8.7 | 81 | 81 | 12.2 | 101 | 151 |
| 2.2 | 27 | 53 | 5.3 | 57 | 93 | 8.8 | 81 | 125 | 12.3 | 101 | 151 |
| 2.3 | 27 | 53 | 5.4 | 57 | 93 | 8.9 | 81 | 125 | 12.4 | 101 | 151 |
| 2.4 | 30 | 57 | 5.5 | 57 | 93 | 9 | 81 | 125 | 12.5 | 101 | 151 |
| 2.5 | 30 | 57 | 5.6 | 57 | 93 | 9.1 | 81 | 125 | 12.6 | 101 | 151 |
| 2.6 | 30 | 57 | 5.7 | 57 | 93 | 9.2 | 81 | 125 | 12.7 | 101 | 151 |
| 2.7 | 33 | 61 | 5.8 | 57 | 93 | 9.3 | 81 | 125 | 12.8 | 101 | 151 |
| 2.8 | 33 | 61 | 5.9 | 57 | 93 | 9.4 | 81 | 125 | 12.9 | 101 | 151 |
| 2.9 | 33 | 61 | 6 | 57 | 93 | 9.5 | 81 | 125 | 13 | 101 | 151 |
| 3 | 33 | 61 | 6.1 | 63 | 101 | 9.6 | 81 | 125 | 13.5 | 108 | 160 |
| 3.1 | 36 | 65 | 6.2 | 63 | 101 | 9.7 | 81 | 133 | 14 | 108 | 160 |
| 3.2 | 36 | 65 | 6.3 | 63 | 101 | 9.8 | 87 | 133 | 14.5 | 114 | 169 |
| 3.3 | 36 | 65 | 6.4 | 63 | 101 | 9.9 | 87 | 133 | 15 | 114 | 169 |
| 3.4 | 39 | 70 | 6.5 | 63 | 101 | 10 | 87 | 133 | 15.5 | 120 | 178 |
| 3.5 | 39 | 70 | 6.6 | 63 | 101 | 10.1 | 87 | 133 | 16 | 120 | 178 |
| 3.6 | 39 | 70 | 6.7 | 63 | 101 | 10.2 | 87 | 133 | 16.5 | 125 | 184 |
| 3.7 | 39 | 70 | 6.8 | 69 | 109 | 10.3 | 87 | 133 | 17 | 125 | 184 |
| 3.8 | 43 | 75 | 6.9 | 69 | 109 | 10.4 | 87 | 133 | 17.5 | 130 | 191 |
| 3.9 | 43 | 75 | 7 | 69 | 109 | 10.5 | 87 | 133 | 18 | 130 | 191 |
| 4 | 43 | 75 | 7.1 | 69 | 109 | 10.6 | 87 | 133 | 18.5 | 135 | 198 |
| 4.1 | 43 | 75 | 7.2 | 69 | 109 | 10.7 | 94 | 142 | 19 | 135 | 198 |
| 4.2 | 43 | 75 | 7.3 | 69 | 109 | 10.8 | 94 | 142 | 19.5 | 140 | 205 |
| 4.3 | 47 | 80 | 7.4 | 69 | 109 | 10.9 | 94 | 142 | 20 | 140 | 205 |
| 4.4 | 47 | 80 | 7.5 | 69 | 109 | 11 | 94 | 142 | | | |

DIN standard

ASME/ANSI standard

REDUCE SHANK

DIN-338 HSS DRILL BIT

10mm(3/8") ;13mm(1/2")
Reduce shank

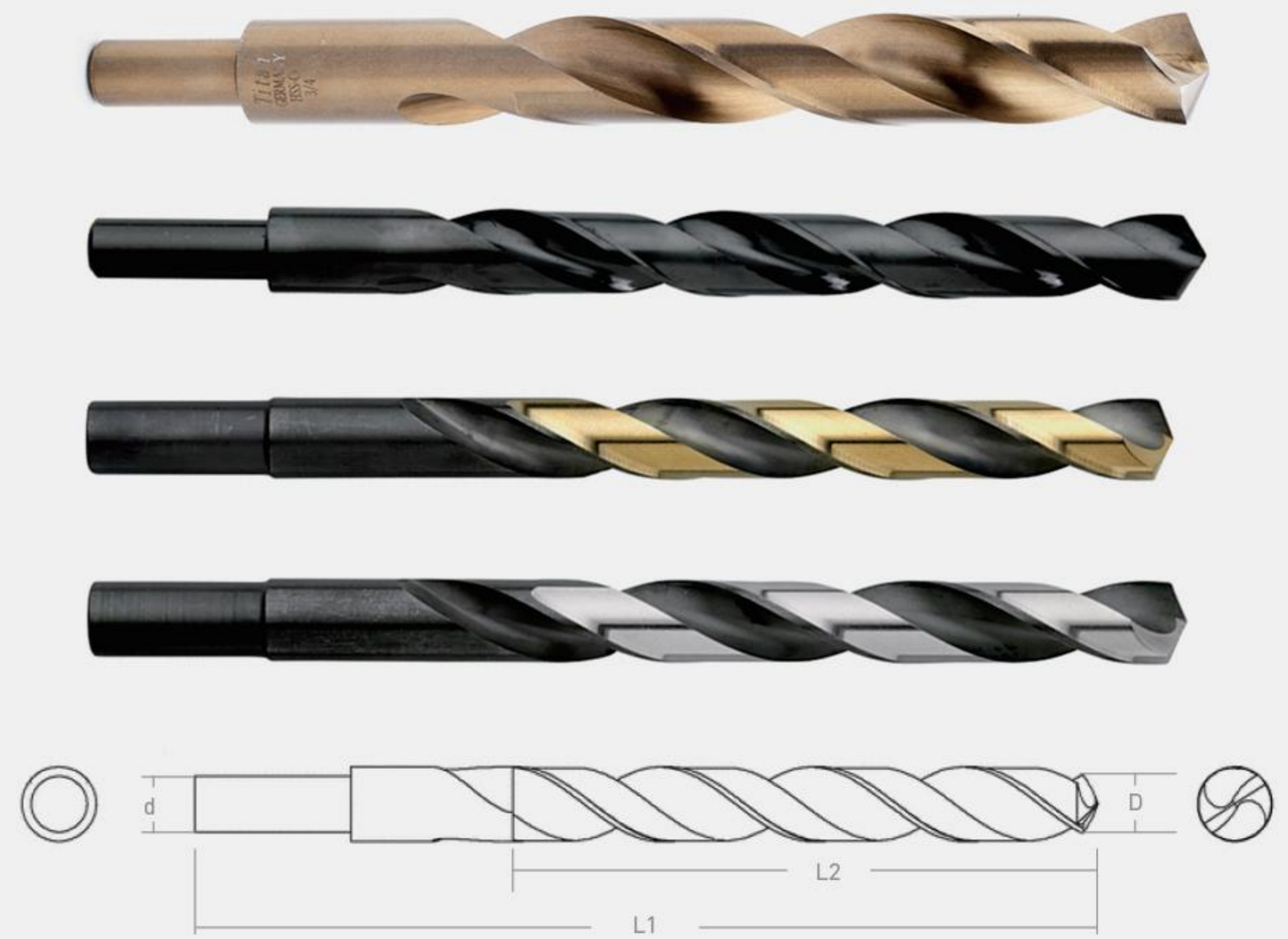
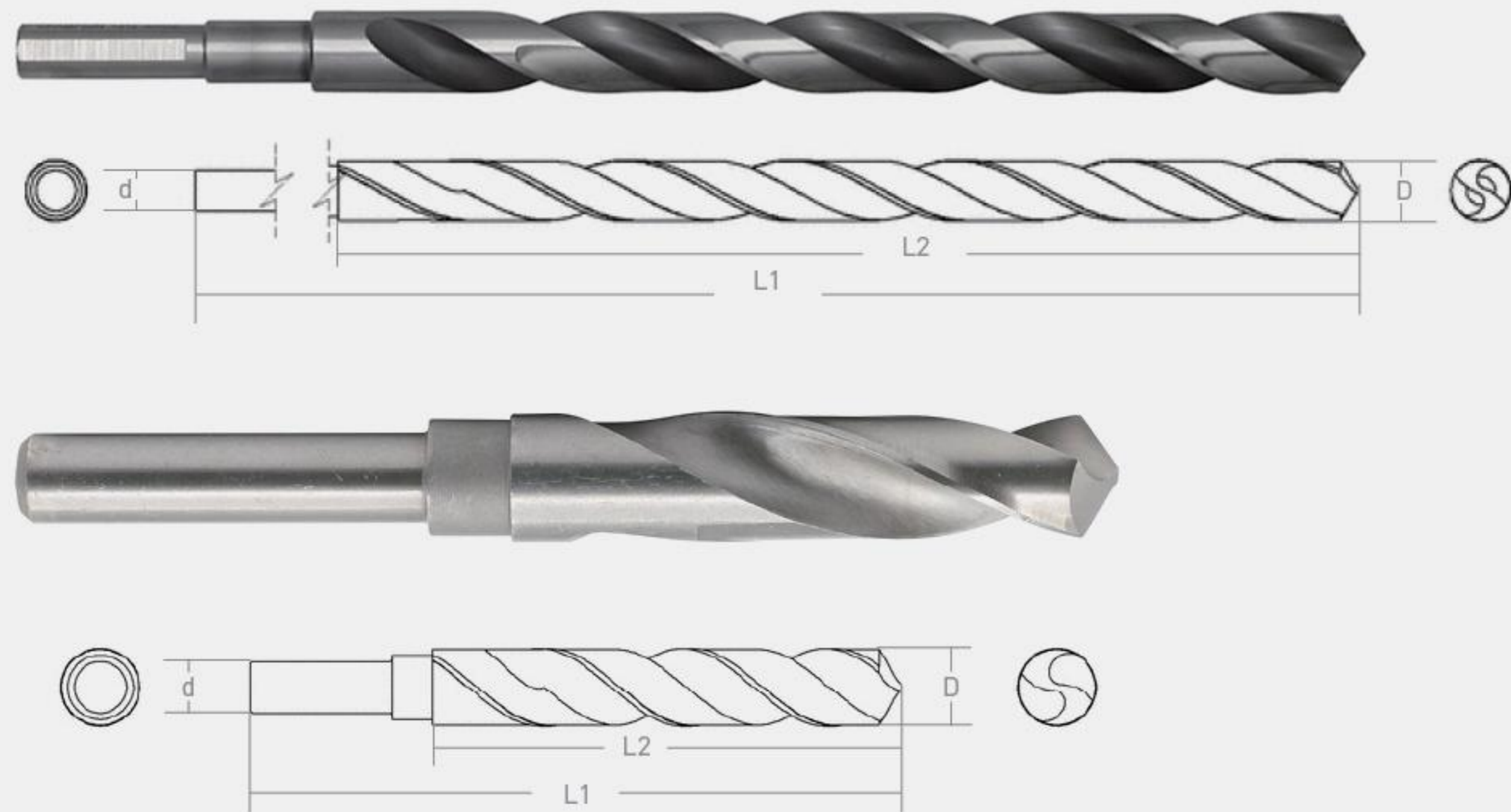

| Dia | L2 | L1 | d |
|------|-----|-----|------|
| 10.5 | 87 | 133 | 10.0 |
| 11 | 94 | 142 | 10.0 |
| 11.5 | 94 | 142 | 10.0 |
| 12 | 101 | 151 | 10.0 |
| 12.5 | 101 | 151 | 10.0 |
| 13 | 101 | 151 | 10.0 |
| 13.5 | 108 | 160 | 10.0 |
| 13.5 | 108 | 160 | 13.0 |
| 14 | 108 | 160 | 10.0 |
| 14 | 108 | 160 | 13.0 |
| 14.5 | 114 | 169 | 10.0 |
| 14.5 | 114 | 169 | 13.0 |
| 15 | 114 | 169 | 10.0 |
| 15 | 114 | 169 | 13.0 |
| 15.5 | 120 | 178 | 10.0 |
| 10.5 | 87 | 133 | 10.0 |
| 11 | 94 | 142 | 10.0 |
| 11.5 | 94 | 142 | 10.0 |
| 12 | 101 | 151 | 10.0 |
| 12.5 | 101 | 151 | 10.0 |
| 13 | 101 | 151 | 10.0 |
| 13.5 | 108 | 160 | 10.0 |
| 13.5 | 108 | 160 | 13.0 |
| 14 | 108 | 160 | 10.0 |
| 14 | 108 | 160 | 13.0 |
| 14.5 | 114 | 169 | 10.0 |
| 14.5 | 114 | 169 | 13.0 |
| 15 | 114 | 169 | 10.0 |
| 15 | 114 | 169 | 13.0 |
| 15.5 | 120 | 178 | 10.0 |
| 15.5 | 120 | 178 | 13.0 |
| 16 | 120 | 178 | 10.0 |
| 16 | 120 | 178 | 13.0 |
| 16.5 | 125 | 184 | 10.0 |
| 16.5 | 125 | 184 | 13.0 |
| 17 | 125 | 184 | 10.0 |
| 17 | 125 | 184 | 13.0 |
| 17.5 | 130 | 191 | 13.0 |
| 18 | 130 | 191 | 10.0 |
| 18 | 130 | 191 | 13.0 |
| 18.5 | 135 | 198 | 13.0 |
| 19 | 135 | 198 | 13.0 |
| 19.5 | 140 | 205 | 13.0 |
| 20 | 140 | 205 | 10.0 |
| 20 | 140 | 205 | 13.0 |

Other sizes are available

DIN standard

ASME/ANSI standard

HEX SHANK

DIN-338 HSS DRILL BIT

HSS HEX SHANK SHORT DRILL BIT



STANDARD: DIN338 OR CUSTOMIZED

SIZE: 01.0~013.0 / 3/64"~1/2"

MATERIAL: 4241, 4341, M2, M35

PROCESS: FULLY GROUND, ROLLED

POINT ANGLE: 118°/135°

DIN standard

ASME/ANSI standard

HSS HEX SHANK SHORT DRILL BIT

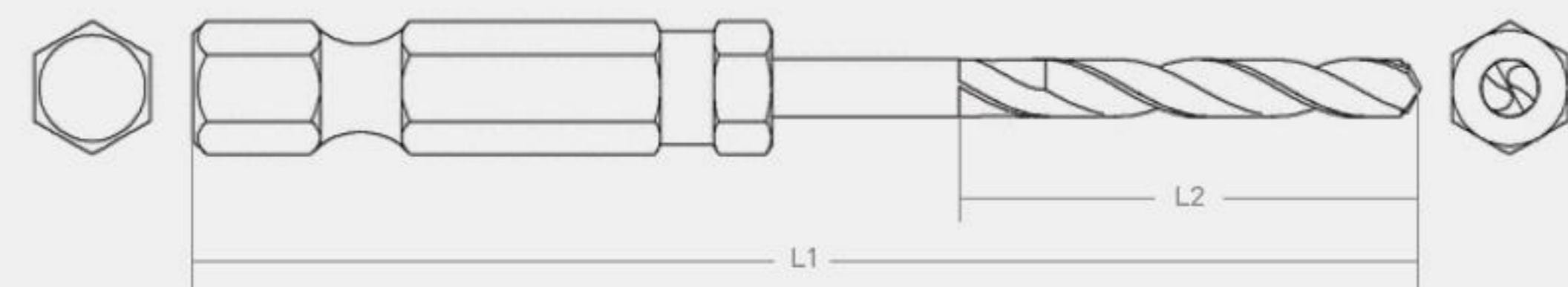

| Dia | L2 | L1 | Dia | L2 | L1 | Dia | L2 | L1 |
|-----|----|----|-----|----|----|------|----|----|
| 1.0 | 7 | 32 | 5.0 | 26 | 50 | 9.5 | 38 | 54 |
| 1.5 | 10 | 34 | 5.1 | 26 | 50 | 10.0 | 38 | 54 |
| 2.0 | 12 | 36 | 5.2 | 26 | 50 | 10.2 | 38 | 54 |
| 2.5 | 14 | 38 | 5.5 | 26 | 50 | 10.5 | 44 | 60 |
| 3.0 | 16 | 38 | 6.0 | 26 | 50 | 11.0 | 44 | 60 |
| 3.1 | 16 | 40 | 6.1 | 26 | 50 | 12.0 | 44 | 60 |
| 3.3 | 18 | 40 | 6.5 | 30 | 50 | 12.5 | 44 | 60 |
| 3.5 | 18 | 44 | 6.8 | 30 | 50 | 13.0 | 44 | 60 |
| 4.0 | 20 | 44 | 7.0 | 30 | 50 | | | |
| 4.1 | 20 | 44 | 7.5 | 32 | 51 | | | |
| 4.2 | 20 | 46 | 8.0 | 32 | 51 | | | |
| 4.5 | 24 | 46 | 8.5 | 33 | 53 | | | |
| 4.9 | 24 | 50 | 9.0 | 33 | 53 | | | |

PACKING FOR TWIST DRILL BIT

| | | |
|---|--|---|
| <p>A</p>  <p>PVC bag 1.0-8.0 mm 10PCS/bag 8.5-13.0 mm 5PCS/bag</p> | <p>B</p>  <p>PVC bag/With hanging hole 1.0-8.0 mm 10PCS/bag 8.5-13.0 mm 5PCS/bag</p> | <p>C</p>  <p>Square tube with hook 1.0-9.5 mm 10PCS/tube 9.5-13.0 mm 5PCS/tube</p> |
| <p>D</p>  <p>Square tube 1.0-9.5 mm 10PCS/tube 9.6-13.0 mm 5PCS/tube</p> | <p>E</p>  <p>Paper bag 1.0-8.0 mm 10PCS/bag 8.5-13.0 mm 5PCS/bag</p> | <p>F</p>  <p>Blister card</p> |
| <p>G</p>  <p>Plastic case 1.0-8.0 mm 10PCS/plastic box 8.5-13.0 mm 5PCS/plastic box</p> | <p>H</p>  <p>Package for Twist Drill Iner box :①White box ②Color box Out carton /w pallet:③</p> | |

DIN standard

ASME/ANSI standard

HSS TWIST DRILL SET

ECH501



5PCS TWIST DRILL SET
Size(mm):1.5,2.5,3,4,5mm

ECH502



5PCS TWIST DRILL SET
Size(mm):4,5,6,8,10mm

ECH601



6PCS TWIST DRILL SET
Size(mm):2,3,4,5,6,8mm

ECH801



8PCS TWIST DRILL SET
Size(mm):3,4,5,6,7,8,9,10mm

ECH802

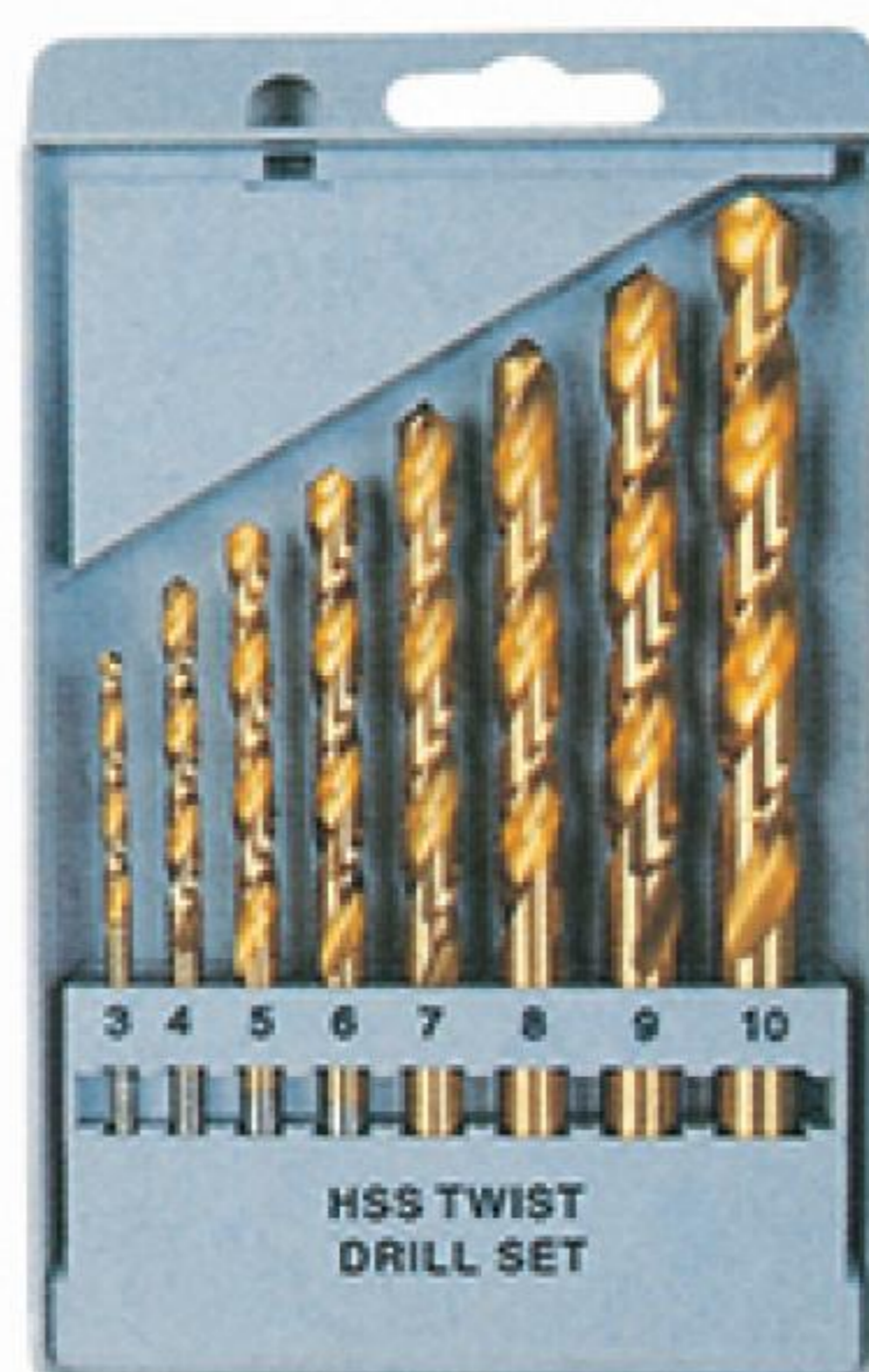

8PCS TWIST DRILL SET
Size(mm):3-10 × 1mm

ECH803



8PCS TWIST DRILL SET
Size(mm):3-10 × 1mm

ECH1001

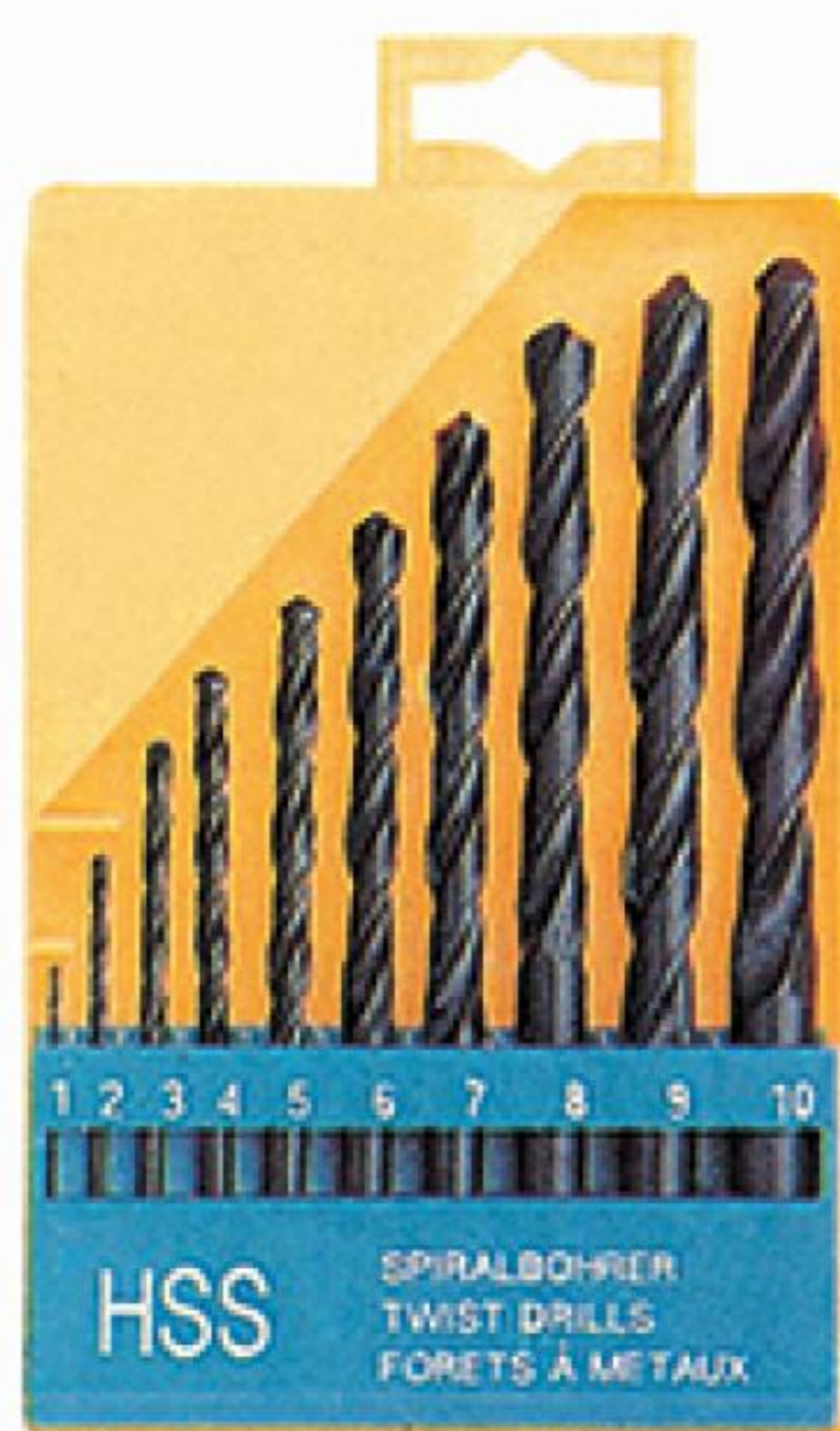

10PCS TWIST DRILL SET
Size(mm):1-10 × 1mm

ECH1301



13PCS TWIST DRILL SET
Size(mm):1.5-6.5 × 0.5+3.2+4.8mm

ECH1302

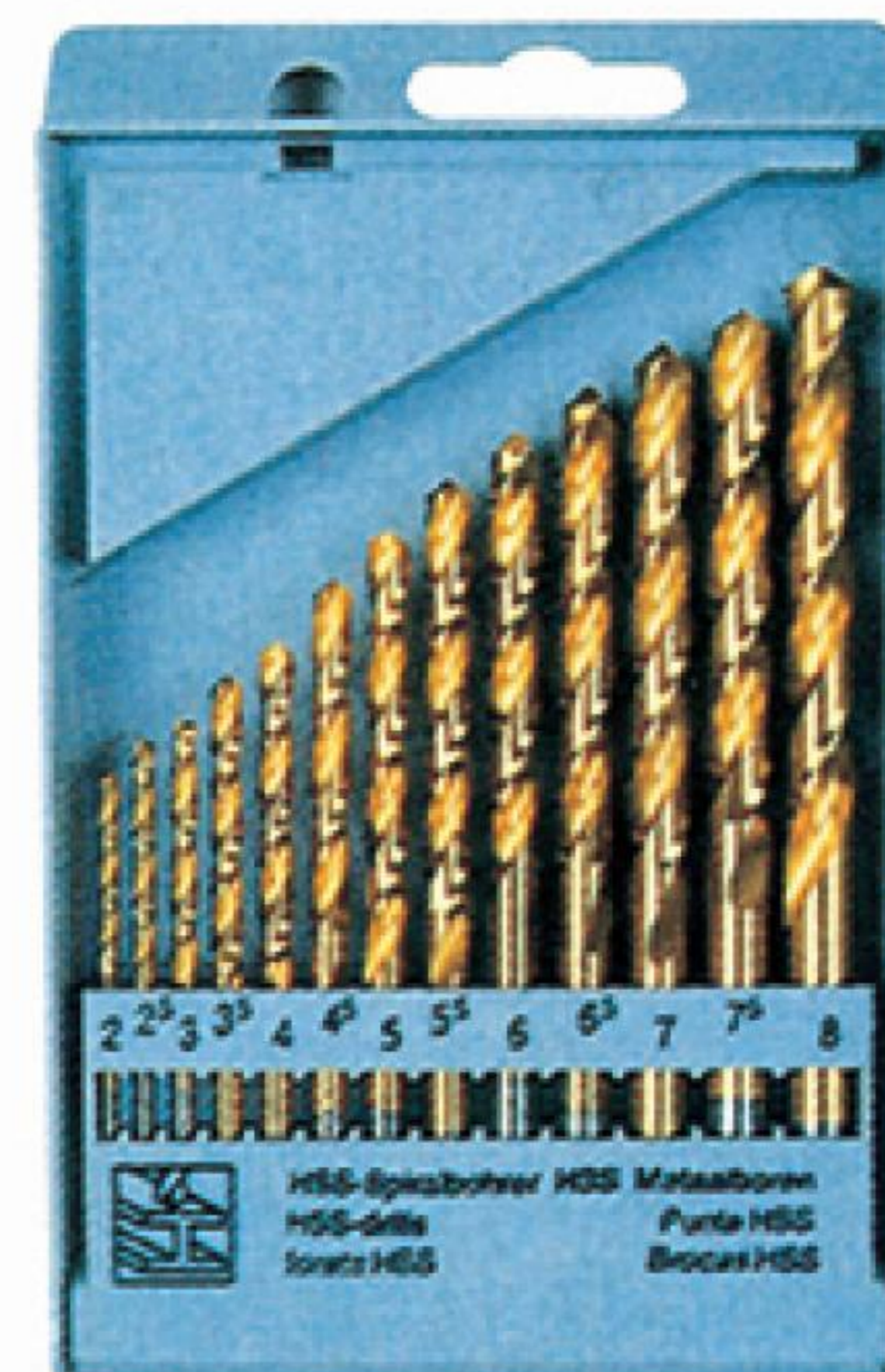

13PCS TWIST DRILL SET
Size(mm):2-8 × 0.5mm

DIN standard

ASME/ANSI standard

HSS TWIST DRILL SET

ECH1303



13PCS TWIST DRILL SET
Size(mm):1.5-6.5 × 0.5+3.2+4.8mm

ECH1304

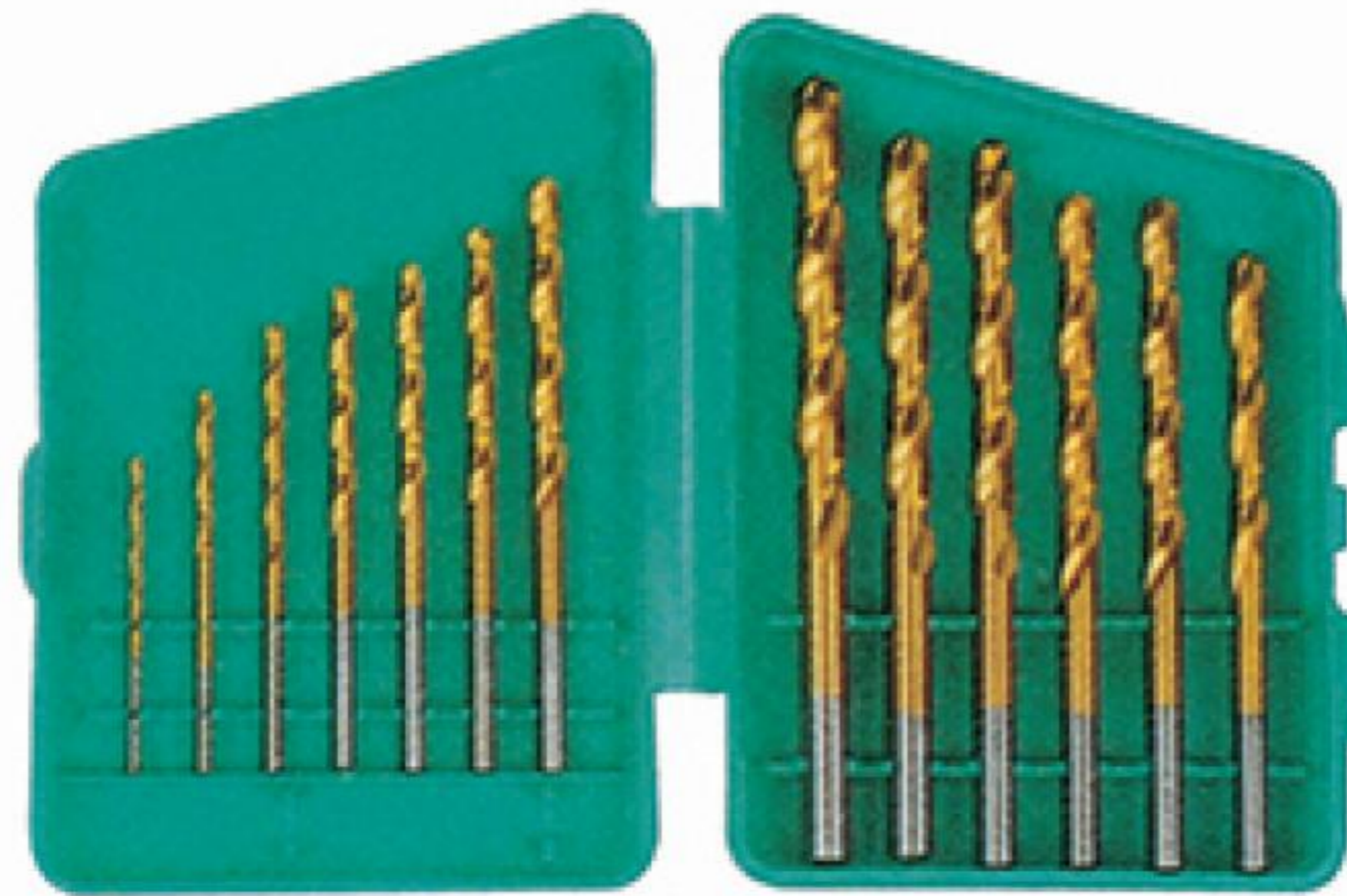

13PCS TWIST DRILL SET
Size(mm):1.5-6.5 × 0.5+3.2+4.8mm

ECH1305



13PCS TWIST DRILL SET
Size(mm):1.5-6.5 × 0.5+3.2+4.8mm

ECH1306



13PCS TWIST DRILL SET
Size(mm):1.5-6.5 × 0.5+3.2+4.8mm

ECH1307

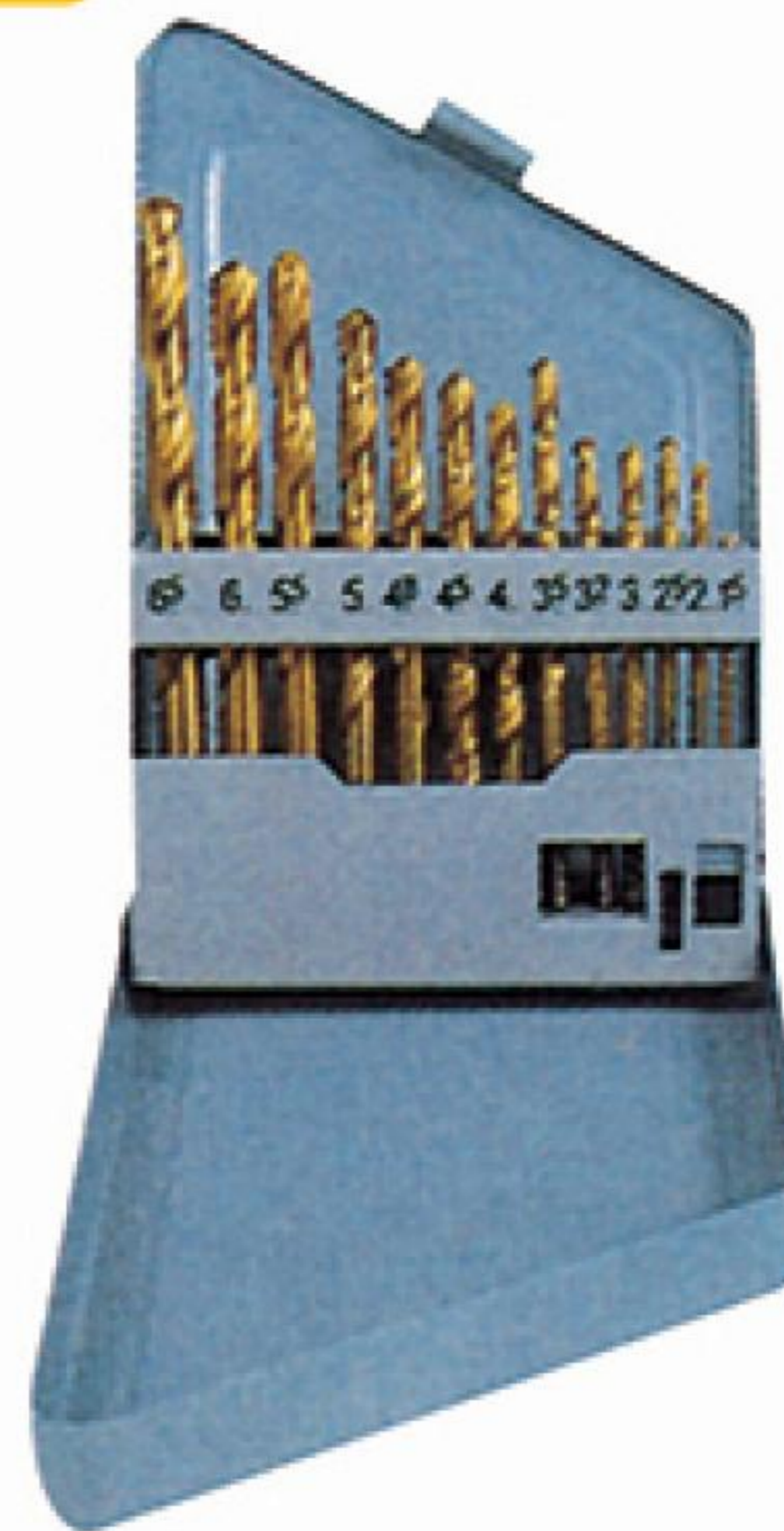

13PCS TWIST DRILL SET
Size(mm):1.5-6.5 × 0.5+3.2+4.8mm

ECH1308

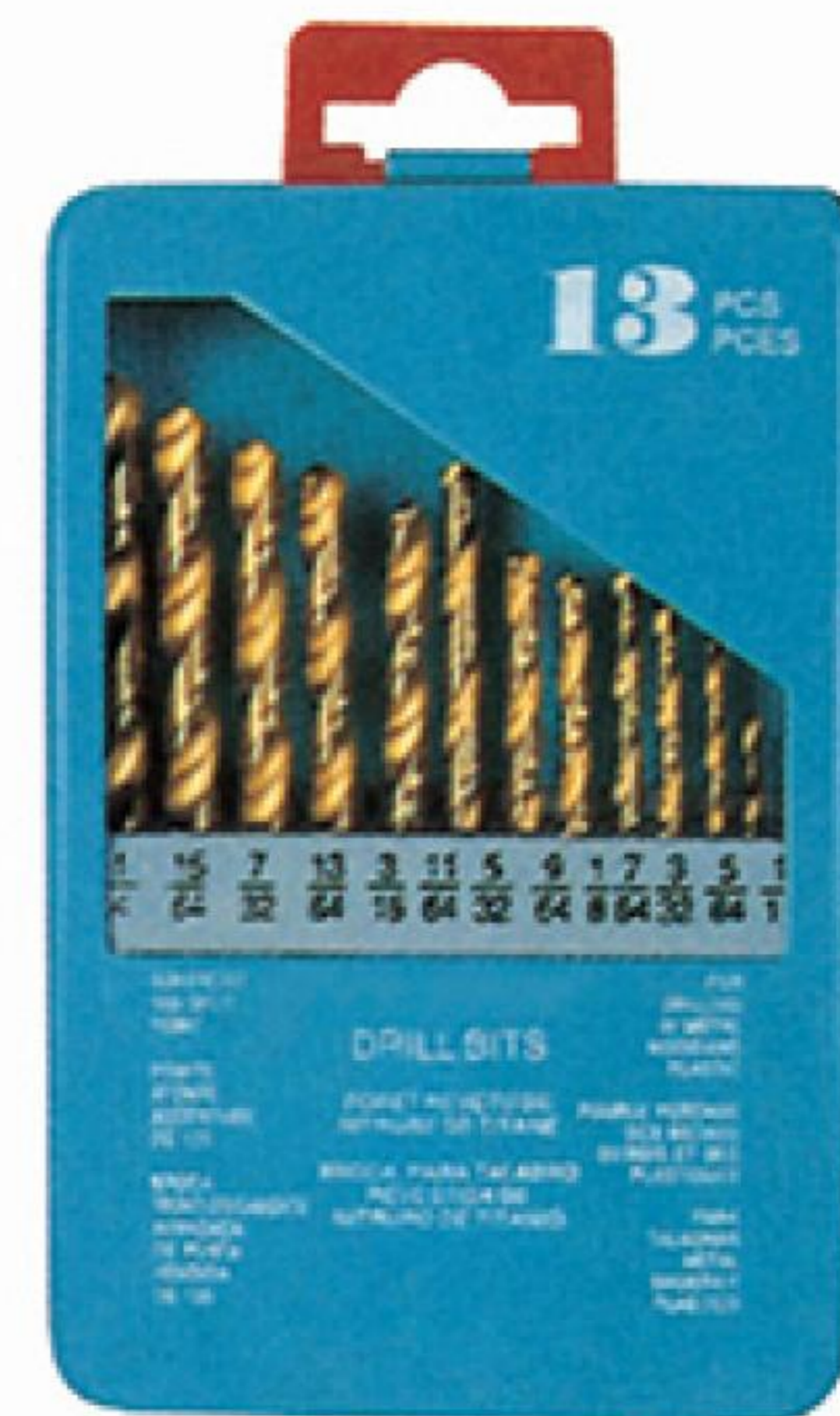

13PCS TWIST DRILL SET
Size(mm):1/16-1/4 × 1/64inch

ECH1309



13PCS TWIST DRILL SET
Size(mm):1.5-6.5mm

ECH1901



19PCS TWIST DRILL SET
Size(mm):1.0-10.0 × 0.5mm

ECH1902

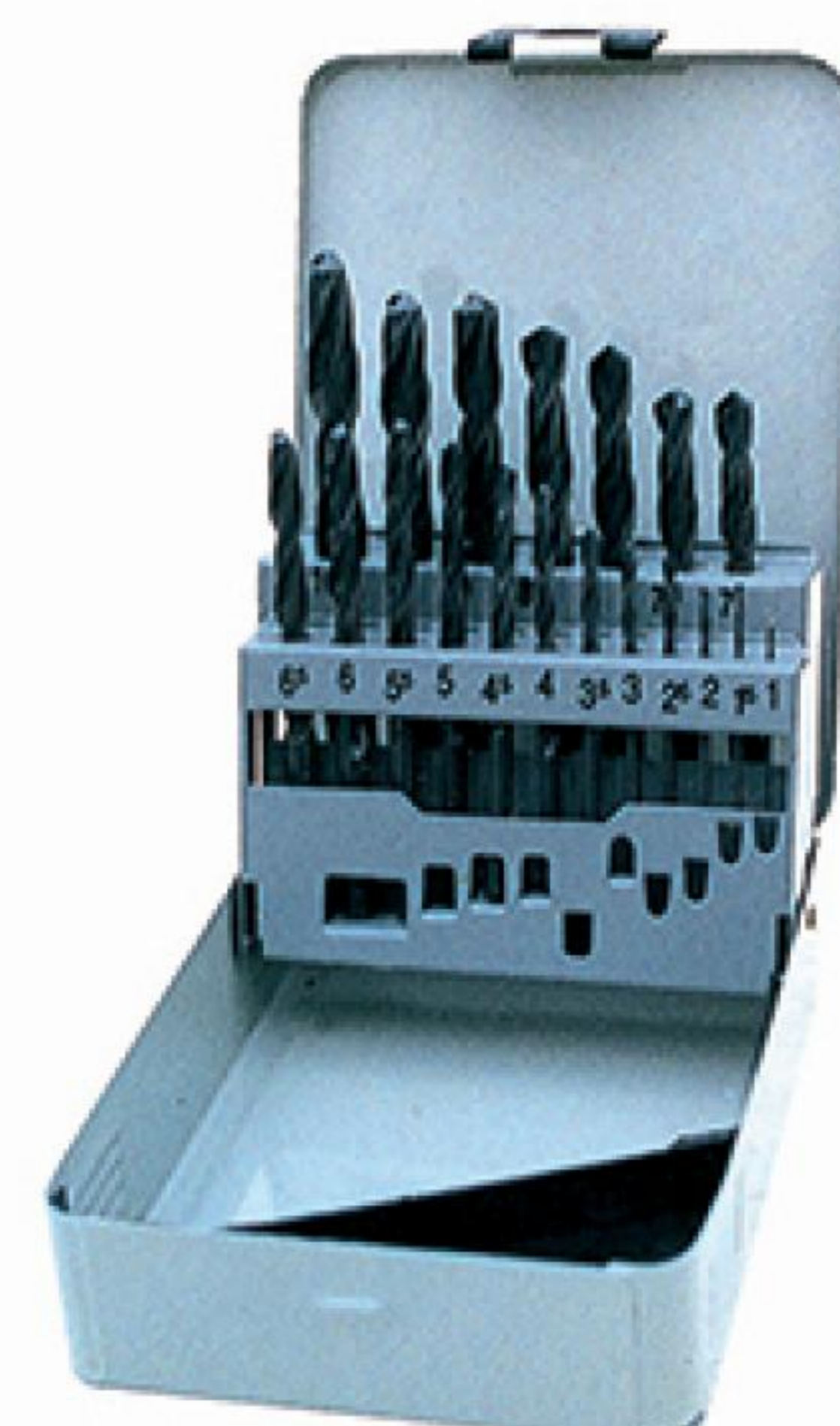

19PCS TWIST DRILL SET
Size(mm):1.0-10.0 × 0.5mm

DIN standard

ASME/ANSI standard

HSS TWIST DRILLS SET

ECH1903



19PCS TWIST DRILL SET
Size(mm):1.0-7.0 × 0.5mm+8-13mm × 1mm

ECH1904



19PCS TWIST DRILL SET
Size(mm):1.0-10.0 × 0.5mm

ECH1905



19PCS TWIST DRILL SET
Size(mm):1.0-10.0 × 0.5mm

ECH1906

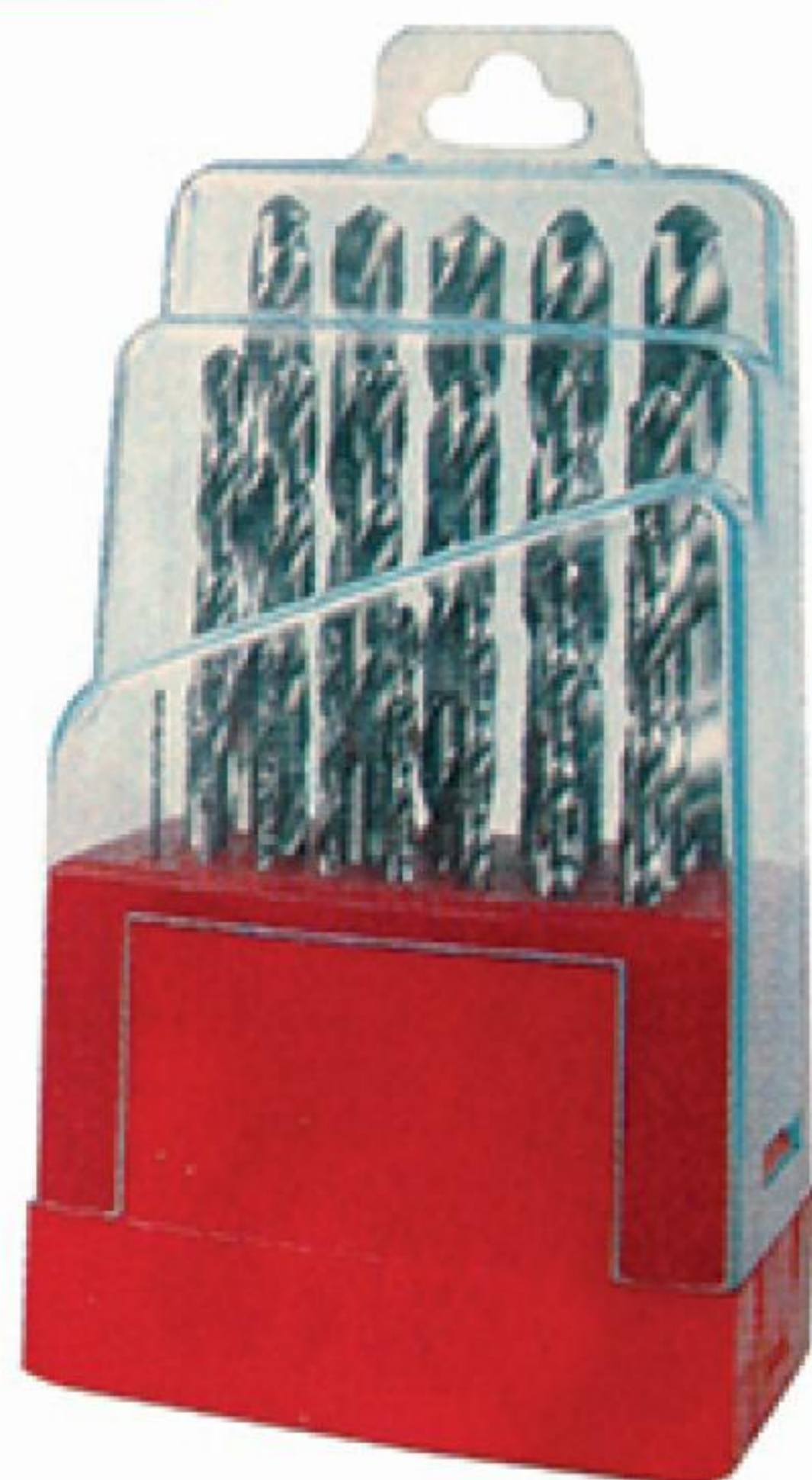

19PCS TWIST DRILL SET
Size(mm):1.0-10.0 × 0.5mm

ECH1907



19PCS TWIST DRILL SET
Size(mm):1.0-10.5 × 0.5mm

ECH1908



19PCS TWIST DRILL SET
Size(mm):1.0-10.0 × 0.5mm

ECH1909



19PCS TWIST DRILL SET
Size(mm):1.0-10.0 × 0.5mm

ECH1910

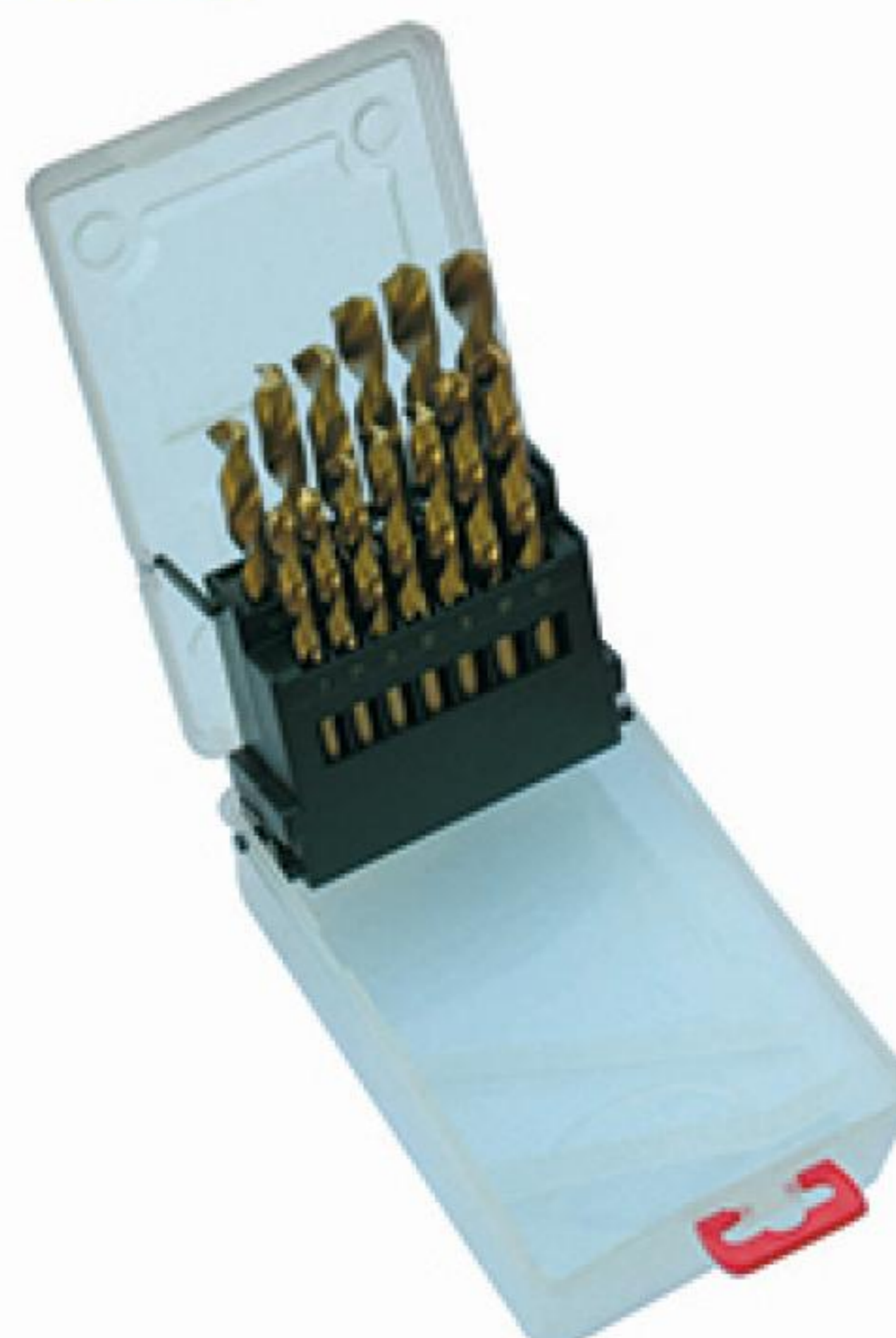

19PCS TWIST DRILL SET
Size(mm):1.0-10.0 × 0.5mm

ECH1911



19PCS TWIST DRILL SET
Size(mm):1.0-10.0 × 0.5mm

DIN standard

ASME/ANSI standard

HSS TWIST DRILLS SET

ECH2502



25PCS TWIST DRILL SET
Size(mm):1.0-13.0 × 0.5mm

ECH2503



25PCS TWIST DRILL SET
Size(mm):1.0-13.0 × 0.5mm

ECH2504



25PCS TWIST DRILL SET
Size(mm):1.0-13.0 × 0.5mm

ECH2505



25PCS TWIST DRILL SET
Size(mm):1.0-13.0 × 0.5mm

ECH2506



25PCS TWIST DRILL SET
Size(mm):1.0-13.0 × 0.5mm

ECH2507



25PCS TWIST DRILL SET
Size(mm):1.0-13.0 × 0.5mm

ECH2508

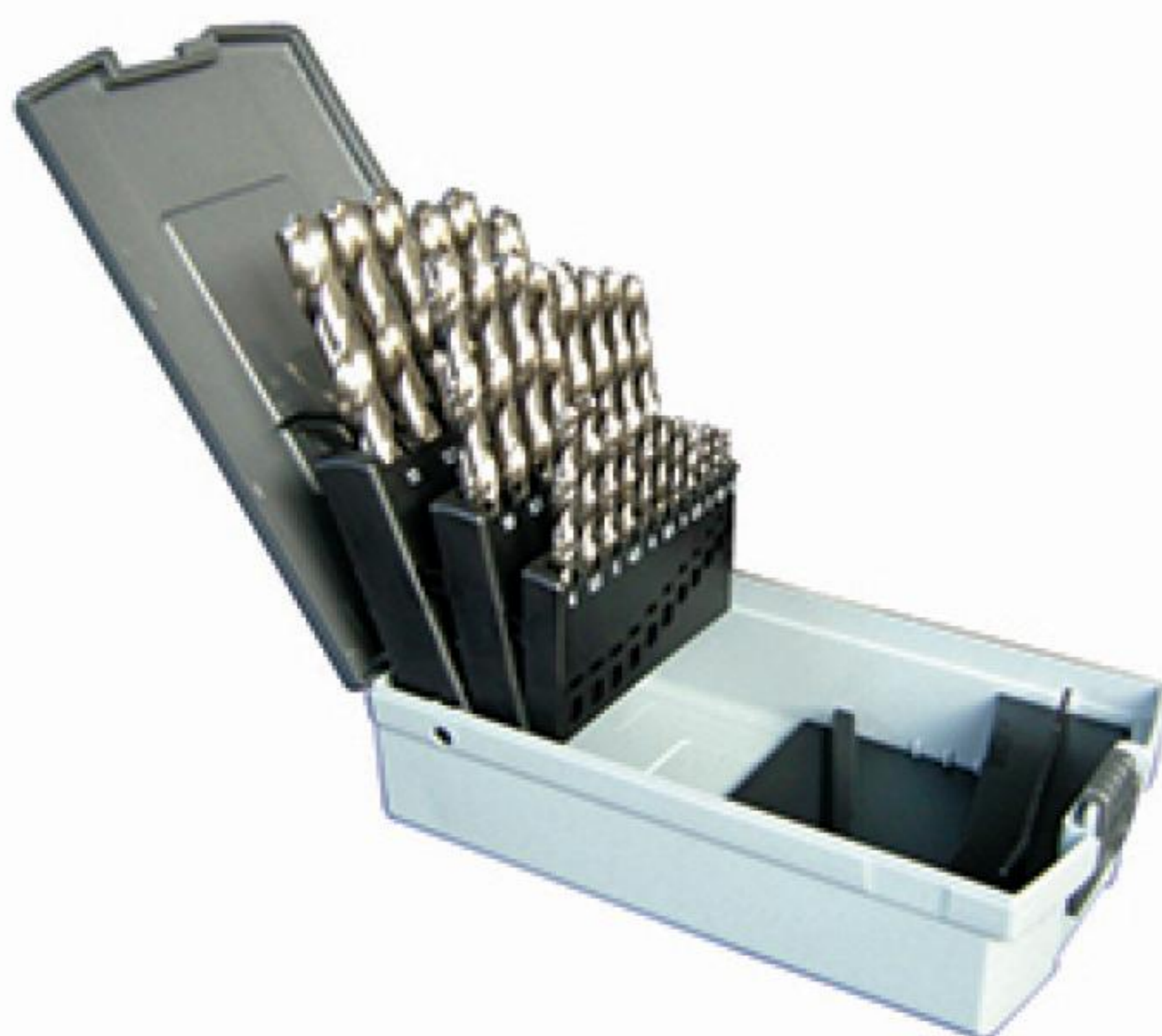

25PCS TWIST DRILL SET
Size(mm):1.0-13.0 × 0.5mm

ECH1912



19PCS TWIST DRILL SET
Size(mm):1.0-10.0 × 0.5mm

ECH1913



19PCS TWIST DRILL SET
Size(mm):1.0-10.0 × 0.5mm

STRAIGHT SHANK

DIN-340 HSS DRILL BIT

HIGH-SPEED STEEL DRILL BIT

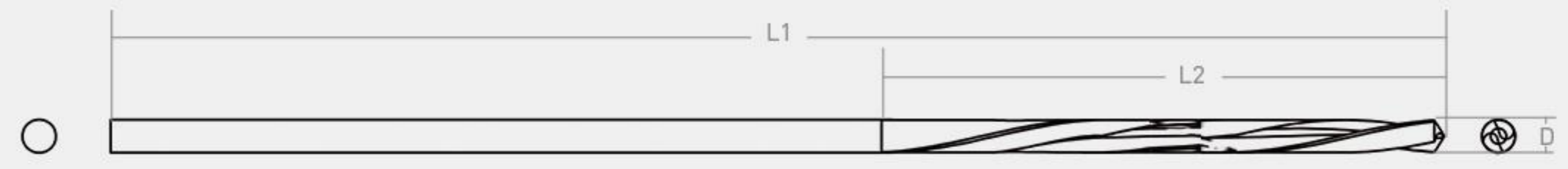

| Dia. | L2 | L1 | Dia. | L2 | L1 | Dia. | L2 | L1 | Dia. | L2 | L1 |
|------|----|-----|------|-----|-----|------|-----|-----|-------|-----|-----|
| 1 | 33 | 56 | 5 | 87 | 132 | 9 | 115 | 175 | 13 | 134 | 205 |
| 1.1 | 37 | 60 | 5.1 | 87 | 132 | 9.1 | 115 | 175 | 13.1 | 134 | 205 |
| 1.2 | 41 | 65 | 5.2 | 87 | 132 | 9.2 | 115 | 175 | 13.2 | 134 | 205 |
| 1.3 | 41 | 65 | 5.3 | 87 | 132 | 9.3 | 115 | 175 | 13.3 | 140 | 214 |
| 1.4 | 45 | 70 | 5.4 | 91 | 139 | 9.4 | 115 | 175 | 13.4 | 140 | 214 |
| 1.5 | 45 | 70 | 5.5 | 91 | 139 | 9.5 | 115 | 175 | 13.5 | 140 | 214 |
| 1.6 | 50 | 76 | 5.6 | 91 | 139 | 9.6 | 121 | 175 | 13.6 | 140 | 214 |
| 1.7 | 50 | 76 | 5.7 | 91 | 139 | 9.7 | 121 | 184 | 13.7 | 140 | 214 |
| 1.8 | 53 | 80 | 5.8 | 91 | 139 | 9.8 | 121 | 184 | 13.8 | 140 | 214 |
| 1.9 | 53 | 80 | 5.9 | 91 | 139 | 9.9 | 121 | 184 | 13.9 | 140 | 214 |
| 2 | 56 | 85 | 6 | 91 | 139 | 10 | 121 | 184 | 14 | 140 | 214 |
| 2.1 | 56 | 85 | 6.1 | 97 | 148 | 10.1 | 121 | 184 | 14.25 | 144 | 220 |
| 2.2 | 56 | 90 | 6.2 | 97 | 148 | 10.2 | 121 | 184 | 14.5 | 144 | 220 |
| 2.3 | 56 | 90 | 6.3 | 97 | 148 | 10.3 | 121 | 184 | 14.75 | 144 | 220 |
| 2.4 | 62 | 95 | 6.4 | 97 | 148 | 10.4 | 121 | 184 | 15 | 144 | 220 |
| 2.5 | 62 | 95 | 6.5 | 97 | 148 | 10.5 | 121 | 184 | 15.25 | 149 | 227 |
| 2.6 | 62 | 95 | 6.6 | 97 | 148 | 10.6 | 121 | 184 | 15.5 | 149 | 227 |
| 2.7 | 66 | 100 | 6.7 | 97 | 148 | 10.7 | 128 | 195 | 15.75 | 149 | 227 |
| 2.8 | 66 | 100 | 6.8 | 102 | 148 | 10.8 | 128 | 195 | 16 | 149 | 227 |
| 2.9 | 66 | 100 | 6.9 | 102 | 156 | 10.9 | 128 | 195 | 16.25 | 154 | 235 |
| 3 | 66 | 100 | 7 | 102 | 156 | 11 | 128 | 195 | 16.5 | 154 | 235 |
| 3.1 | 69 | 106 | 7.1 | 102 | 156 | 11.1 | 128 | 195 | 16.75 | 154 | 235 |
| 3.2 | 69 | 106 | 7.2 | 102 | 156 | 11.2 | 128 | 195 | 17 | 154 | 235 |
| 3.3 | 69 | 106 | 7.3 | 102 | 156 | 11.3 | 128 | 195 | 17.25 | 158 | 241 |
| 3.4 | 73 | 110 | 7.4 | 102 | 156 | 11.4 | 128 | 195 | 17.5 | 158 | 241 |
| 3.5 | 73 | 110 | 7.5 | 102 | 156 | 11.5 | 128 | 195 | 17.75 | 158 | 241 |
| 3.6 | 73 | 110 | 7.6 | 109 | 156 | 11.6 | 128 | 195 | 18 | 158 | 241 |
| 3.7 | 73 | 110 | 7.7 | 109 | 165 | 11.7 | 128 | 195 | 18.25 | 162 | 247 |
| 3.8 | 78 | 119 | 7.8 | 109 | 165 | 11.8 | 128 | 195 | 18.5 | 162 | 247 |
| 3.9 | 78 | 119 | 7.9 | 109 | 165 | 11.9 | 134 | 205 | 18.75 | 162 | 247 |
| 4 | 78 | 119 | 8 | 109 | 165 | 11 | 134 | 205 | 19 | 162 | 247 |
| 4.1 | 78 | 119 | 8.1 | 109 | 165 | 12.1 | 134 | 205 | 19.25 | 166 | 254 |
| 4.2 | 82 | 126 | 8.2 | 109 | 165 | 12.2 | 134 | 205 | 19.5 | 166 | 254 |
| 4.3 | 82 | 126 | 8.3 | 109 | 165 | 12.3 | 134 | 205 | 19.75 | 166 | 254 |
| 4.4 | 82 | 126 | 8.4 | 109 | 165 | 12.4 | 134 | 205 | 20 | 166 | 254 |
| 4.5 | 82 | 126 | 8.5 | 109 | 165 | 12.5 | 134 | 205 | | | |
| 4.6 | 82 | 126 | 8.6 | 115 | 165 | 12.6 | 134 | 205 | | | |
| 4.7 | 82 | 132 | 8.7 | 115 | 175 | 12.7 | 134 | 205 | | | |
| 4.8 | 87 | 132 | 8.8 | 115 | 175 | 12.8 | 134 | 205 | | | |
| 4.9 | 87 | 132 | 8.9 | 115 | 175 | 12.9 | 134 | 205 | | | |

Other sizes are available

DIN standard

ASME/ANSI standard

HSS TAPER SHANK

DIN-345 HSS DRILL BIT

ROLL FORGED / MILLED

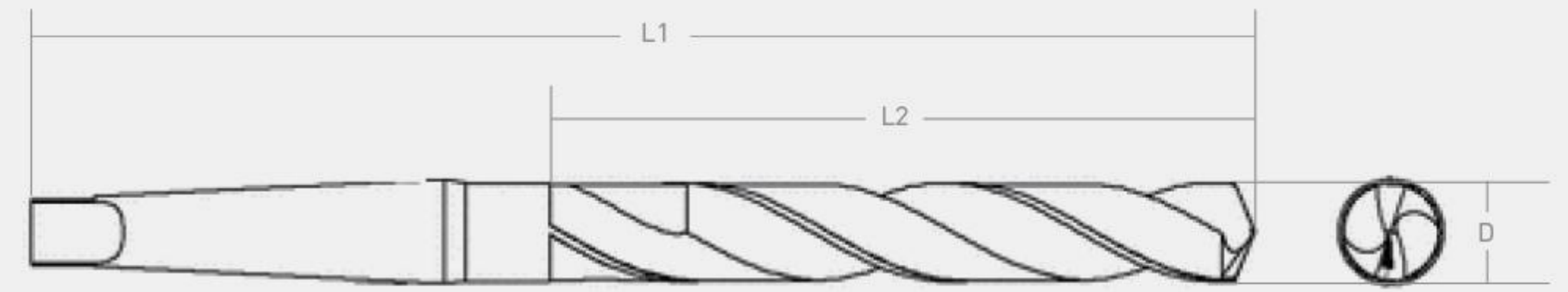

| Dia. | L2 | L1 | Dia. | L2 | L1 | Dia. | L2 | L1 | Dia. | L2 | L1 |
|-------|-----|-----|-------|-----|-----|-------|-----|-----|------|-----|-----|
| 8 | 75 | 156 | 18.5 | 135 | 233 | 28.75 | 175 | 296 | 47 | 215 | 364 |
| 8.2 | 75 | 156 | 18.75 | 135 | 233 | 29 | 175 | 296 | 47.5 | 215 | 364 |
| 8.5 | 75 | 156 | 19 | 135 | 233 | 29.25 | 175 | 296 | 48 | 220 | 369 |
| 8.8 | 81 | 162 | 19.25 | 140 | 238 | 29.5 | 175 | 296 | 48.5 | 220 | 369 |
| 9 | 81 | 162 | 19.5 | 140 | 238 | 29.75 | 175 | 296 | 49 | 220 | 369 |
| 9.2 | 81 | 162 | 19.75 | 140 | 238 | 30 | 175 | 296 | 49.5 | 220 | 369 |
| 9.5 | 81 | 162 | 20 | 140 | 243 | 30.25 | 180 | 301 | 50 | 220 | 369 |
| 9.8 | 87 | 168 | 20.25 | 145 | 243 | 30.5 | 180 | 301 | 50.5 | 220 | 374 |
| 10 | 87 | 168 | 20.5 | 145 | 243 | 30.75 | 180 | 301 | 51 | 225 | 412 |
| 10.2 | 87 | 168 | 20.75 | 145 | 243 | 31 | 180 | 301 | 52 | 225 | 412 |
| 10.5 | 87 | 168 | 21 | 145 | 248 | 31.25 | 180 | 301 | 53 | 225 | 412 |
| 10.8 | 94 | 175 | 21.25 | 150 | 248 | 31.5 | 180 | 301 | 54 | 230 | 417 |
| 11 | 94 | 175 | 21.5 | 150 | 248 | 31.75 | 185 | 306 | 55 | 230 | 417 |
| 11.2 | 94 | 175 | 21.75 | 150 | 248 | 32 | 185 | 334 | 56 | 230 | 417 |
| 11.5 | 94 | 175 | 22 | 150 | 248 | 32.5 | 185 | 334 | 57 | 235 | 422 |
| 11.8 | 94 | 175 | 22.25 | 150 | 253 | 33 | 185 | 334 | 58 | 235 | 422 |
| 12 | 101 | 182 | 22.5 | 155 | 253 | 33.5 | 185 | 334 | 59 | 235 | 422 |
| 12.2 | 101 | 182 | 22.75 | 155 | 253 | 34 | 190 | 339 | 60 | 235 | 422 |
| 12.5 | 101 | 182 | 23 | 155 | 253 | 34.5 | 190 | 339 | 61 | 240 | 427 |
| 12.8 | 101 | 182 | 23.25 | 155 | 276 | 35 | 190 | 339 | 62 | 240 | 427 |
| 13 | 101 | 182 | 23.5 | 155 | 276 | 35.5 | 190 | 339 | 63 | 240 | 427 |
| 13.2 | 101 | 182 | 23.75 | 160 | 281 | 36 | 195 | 344 | 64 | 245 | 432 |
| 13.5 | 108 | 189 | 24 | 160 | 281 | 36.5 | 195 | 344 | 65 | 245 | 432 |
| 13.8 | 108 | 189 | 24.25 | 160 | 281 | 37 | 195 | 344 | 66 | 245 | 432 |
| 14 | 108 | 189 | 24.5 | 160 | 281 | 38 | 200 | 349 | 67 | 245 | 432 |
| 14.25 | 114 | 212 | 24.75 | 160 | 281 | 38.5 | 200 | 349 | 68 | 250 | 437 |
| 14.5 | 114 | 212 | 25 | 160 | 281 | 39 | 200 | 349 | 69 | 250 | 437 |
| 14.75 | 114 | 212 | 25.25 | 165 | 286 | 39.5 | 200 | 349 | 70 | 250 | 437 |
| 15 | 114 | 212 | 25.5 | 165 | 286 | 40 | 200 | 349 | 71 | 250 | 437 |
| 15.25 | 120 | 218 | 25.75 | 165 | 286 | 40.5 | 205 | 354 | 72 | 255 | 442 |
| 15.5 | 120 | 218 | 26 | 165 | 286 | 41 | 205 | 354 | 73 | 255 | 442 |
| 15.75 | 120 | 218 | 26.25 | 165 | 286 | 41.5 | 205 | 354 | 74 | 255 | 442 |
| 16 | 120 | 218 | 26.5 | 165 | 286 | 42 | 205 | 354 | 75 | 255 | 442 |
| 16.25 | 125 | 223 | 26.75 | 170 | 291 | 42.5 | 205 | 354 | 76 | 260 | 447 |
| 16.5 | 125 | 223 | 27 | 170 | 291 | 43 | 210 | 359 | | | |
| 16.75 | 125 | 223 | 27.25 | 170 | 291 | 43.5 | 210 | 359 | | | |
| 17 | 125 | 223 | 27.5 | 170 | 291 | 44.5 | 210 | 359 | | | |
| 17.25 | 130 | 223 | 27.75 | 170 | 291 | 45 | 210 | 359 | | | |
| 17.5 | 130 | 228 | 28 | 170 | 291 | 45.5 | 215 | 364 | | | |
| 17.75 | 130 | 228 | 28.25 | 175 | 296 | 46 | 215 | 364 | | | |
| 18 | 130 | 228 | 28.5 | 175 | 296 | 46.5 | 215 | 364 | | | |

Other sizes are available

HSS TAPER SHANK

DIN-341 HSS DRILL BIT

ROLL FORGED / MILLED

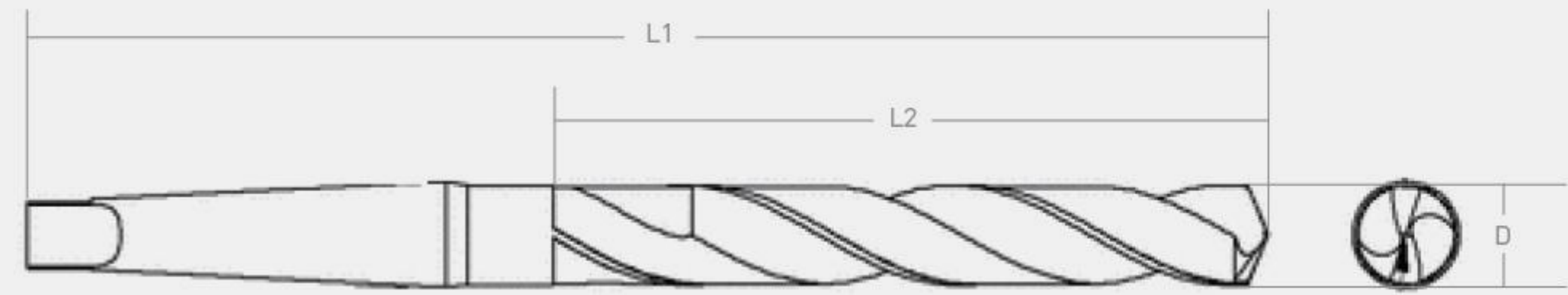

| Dia | L2 | L1 | MT | Dia | L2 | L1 | MT | Dia | L2 | L1 | MT |
|------|-----|-----|----|-------|-----|-----|----|-------|-----|-----|----|
| 5.0 | 74 | 155 | 1 | 17.25 | 165 | 283 | 2 | 29.25 | 230 | 351 | 3 |
| 5.2 | 74 | 155 | 1 | 17.50 | 165 | 283 | 2 | 29.50 | 230 | 351 | 3 |
| 5.5 | 80 | 161 | 1 | 17.75 | 165 | 283 | 2 | 29.75 | 230 | 351 | 3 |
| 5.8 | 80 | 161 | 1 | 18.00 | 165 | 283 | 2 | 30.00 | 230 | 351 | 3 |
| 6.0 | 80 | 161 | 1 | 18.25 | 171 | 269 | 2 | 30.25 | 239 | 360 | 3 |
| 6.2 | 88 | 167 | 1 | 18.50 | 171 | 269 | 2 | 30.50 | 239 | 360 | 3 |
| 6.5 | 88 | 167 | 1 | 18.75 | 171 | 269 | 2 | 30.75 | 239 | 360 | 3 |
| 6.8 | 93 | 174 | 1 | 19.00 | 171 | 269 | 2 | 31.00 | 239 | 360 | 3 |
| 7.0 | 93 | 174 | 1 | 19.25 | 177 | 275 | 2 | 31.25 | 239 | 360 | 3 |
| 7.2 | 93 | 174 | 1 | 19.50 | 177 | 275 | 2 | 31.50 | 239 | 360 | 3 |
| 7.5 | 93 | 174 | 1 | 19.75 | 177 | 275 | 2 | 31.75 | 248 | 369 | 3 |
| 7.8 | 100 | 181 | 1 | 20.00 | 177 | 275 | 2 | 32.00 | 248 | 397 | 3 |
| 8.0 | 100 | 181 | 1 | 20.25 | 184 | 282 | 2 | 32.50 | 248 | 397 | 4 |
| 8.2 | 100 | 181 | 1 | 20.50 | 184 | 282 | 2 | 33.00 | 248 | 397 | 4 |
| 8.5 | 100 | 181 | 1 | 20.75 | 184 | 282 | 2 | 33.50 | 248 | 397 | 4 |
| 8.8 | 107 | 188 | 1 | 21.00 | 184 | 282 | 2 | 34.00 | 257 | 406 | 4 |
| 9.0 | 107 | 188 | 1 | 21.25 | 191 | 289 | 2 | 34.50 | 257 | 406 | 4 |
| 9.2 | 107 | 188 | 1 | 21.50 | 191 | 289 | 2 | 35.00 | 257 | 406 | 4 |
| 9.5 | 107 | 188 | 1 | 21.75 | 191 | 289 | 2 | 35.50 | 257 | 406 | 4 |
| 9.8 | 116 | 197 | 1 | 22.00 | 191 | 289 | 2 | 36.0 | 267 | 416 | 4 |
| 10.0 | 116 | 197 | 1 | 22.25 | 191 | 289 | 2 | 36.50 | 267 | 416 | 4 |
| 10.2 | 116 | 197 | 1 | 22.50 | 198 | 296 | 2 | 37.00 | 267 | 416 | 4 |
| 10.5 | 116 | 197 | 1 | 22.75 | 198 | 296 | 2 | 37.50 | 267 | 416 | 4 |
| 10.8 | 125 | 206 | 1 | 23.00 | 198 | 296 | 2 | 38.00 | 277 | 426 | 4 |
| 11.0 | 125 | 206 | 1 | 23.25 | 198 | 319 | 3 | 38.50 | 277 | 426 | 4 |
| 11.2 | 125 | 206 | 1 | 23.50 | 198 | 319 | 3 | 39.00 | 277 | 426 | 4 |
| 11.5 | 125 | 206 | 1 | 23.75 | 208 | 327 | 3 | 39.50 | 277 | 426 | 4 |
| 11.8 | 125 | 206 | 1 | 24.00 | 208 | 327 | 3 | 40.00 | 277 | 426 | 4 |
| 12.0 | 134 | 215 | 1 | 24.25 | 208 | 327 | 3 | 40.50 | 287 | 436 | 4 |
| 12.2 | 134 | 215 | 1 | 24.50 | 208 | 327 | 3 | 41.00 | 287 | 436 | 4 |
| 12.5 | 134 | 215 | 1 | 24.75 | 208 | 327 | 3 | 41.50 | 287 | 436 | 4 |
| 12.8 | 134 | 215 | 1 | 25.00 | 208 | 327 | 3 | 42.00 | 287 | 436 | 4 |
| 13.0 | 134 | 215 | 1 | 25.25 | 214 | 335 | 3 | 42.50 | 287 | 436 | 4 |
| 13.2 | 134 | 215 | 1 | 25.50 | 214 | 335 | 3 | 43.00 | 298 | 447 | 4 |
| 13.5 | 142 | 223 | 1 | 25.75 | 214 | 335 | 3 | 43.50 | 298 | 447 | 4 |
| 13.8 | 142 | 223 | 1 | 26.00 | 214 | 335 | 3 | 44.00 | 298 | 447 | 4 |
| 14.0 | 142 | 223 | 1 | 26.25 | 214 | 335 | 3 | 44.50 | 298 | 447 | 4 |
| 14.2 | 147 | 245 | 2 | 26.50 | 214 | 335 | 3 | 45.00 | 298 | 447 | 4 |
| 14.5 | 147 | 245 | 2 | 26.75 | 222 | 343 | 3 | 45.50 | 310 | 459 | 4 |
| 14.8 | 147 | 245 | 2 | 27.00 | 222 | 343 | 3 | 46.00 | 310 | 459 | 4 |
| 15.0 | 147 | 245 | 2 | 27.25 | 222 | 343 | 3 | 46.50 | 310 | 459 | 4 |
| 15.2 | 153 | 251 | 2 | 27.50 | 222 | 343 | 3 | 47.00 | 310 | 459 | 4 |
| 15.5 | 153 | 251 | 2 | 27.75 | 222 | 343 | 3 | 47.50 | 310 | 459 | 4 |
| 15.8 | 153 | 251 | 2 | 28.00 | 222 | 343 | 3 | 48.00 | 321 | 470 | 4 |
| 16.0 | 153 | 251 | 2 | 28.25 | 230 | 351 | 3 | 48.50 | 321 | 470 | 4 |
| 16.2 | 159 | 257 | 2 | 28.50 | 230 | 351 | 3 | 49.00 | 321 | 470 | 4 |
| 16.5 | 159 | 257 | 2 | 28.75 | 230 | 351 | 3 | 49.50 | 321 | 470 | 4 |
| 16.8 | 159 | 257 | 2 | 29.00 | 230 | 351 | 3 | 50.00 | 321 | 470 | 4 |
| 17.0 | 159 | 257 | 2 | | | | | | | | |

DIN standard

ASME/ANSI standard

HSS SHORT DRILL BIT

DIN-1897 HSS DRILL BIT

HIGH-SPEED STEEL

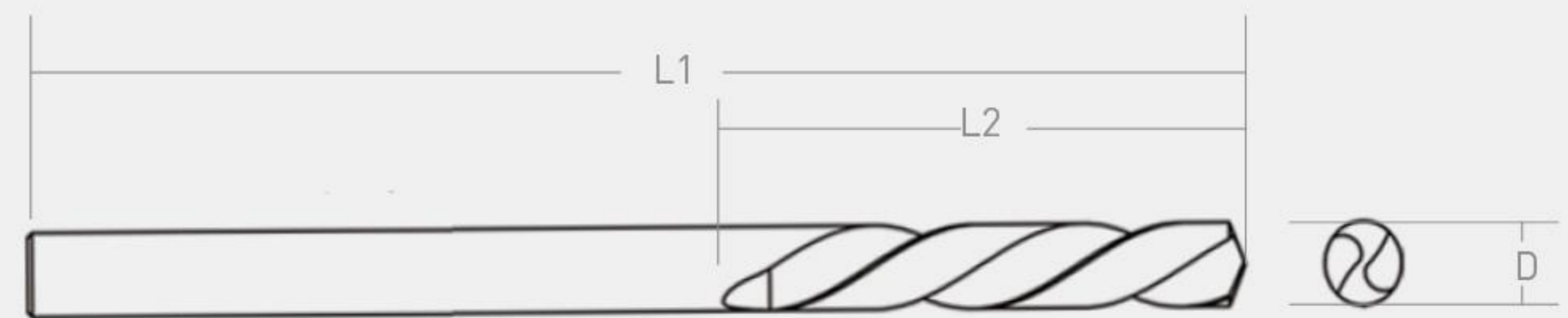

| Dia. | L2 | L1 | Dia. | L2 | L1 | Dia. | L2 | L1 | Dia. | L2 | L1 |
|------|----|----|------|----|----|------|----|-----|-------|----|-----|
| 1 | 6 | 26 | 5 | 26 | 62 | 9 | 40 | 84 | 13 | 51 | 102 |
| 1.1 | 7 | 28 | 5.1 | 26 | 62 | 9.1 | 40 | 84 | 13.1 | 51 | 102 |
| 1.2 | 8 | 30 | 5.2 | 26 | 62 | 9.2 | 40 | 84 | 13.2 | 51 | 102 |
| 1.3 | 8 | 30 | 5.3 | 28 | 66 | 9.3 | 40 | 84 | 13.3 | 54 | 107 |
| 1.4 | 9 | 32 | 5.4 | 28 | 66 | 9.4 | 40 | 84 | 13.4 | 54 | 107 |
| 1.5 | 9 | 32 | 5.5 | 28 | 66 | 9.5 | 40 | 84 | 13.5 | 54 | 107 |
| 1.6 | 10 | 34 | 5.6 | 28 | 66 | 9.6 | 43 | 89 | 13.6 | 54 | 107 |
| 1.7 | 10 | 34 | 5.7 | 28 | 66 | 9.7 | 43 | 89 | 13.7 | 54 | 107 |
| 1.8 | 11 | 36 | 5.8 | 28 | 66 | 9.8 | 43 | 89 | 13.8 | 54 | 107 |
| 1.9 | 11 | 36 | 5.9 | 28 | 66 | 9.9 | 43 | 89 | 13.9 | 54 | 107 |
| 2 | 12 | 38 | 6 | 28 | 66 | 10 | 43 | 89 | 14 | 54 | 107 |
| 2.1 | 12 | 38 | 6.1 | 31 | 70 | 10.1 | 43 | 89 | 14.25 | 56 | 111 |
| 2.2 | 13 | 40 | 6.2 | 31 | 70 | 10.2 | 43 | 89 | 14.5 | 56 | 111 |
| 2.3 | 13 | 40 | 6.3 | 31 | 70 | 10.3 | 43 | 89 | 14.75 | 56 | 111 |
| 2.4 | 14 | 43 | 6.4 | 31 | 70 | 10.4 | 43 | 89 | 15 | 56 | 111 |
| 2.5 | 14 | 43 | 6.5 | 31 | 70 | 10.5 | 43 | 98 | 15.25 | 58 | 115 |
| 2.6 | 14 | 43 | 6.6 | 31 | 70 | 10.6 | 43 | 98 | 15.5 | 58 | 115 |
| 2.7 | 16 | 46 | 6.7 | 31 | 70 | 10.7 | 47 | 95 | 15.75 | 58 | 115 |
| 2.8 | 16 | 46 | 6.8 | 34 | 74 | 10.8 | 47 | 95 | 16 | 58 | 115 |
| 2.9 | 16 | 46 | 6.9 | 34 | 74 | 10.9 | 47 | 95 | 16.25 | 58 | 119 |
| 3 | 16 | 46 | 7 | 34 | 74 | 11 | 47 | 95 | 16.5 | 58 | 119 |
| 3.1 | 18 | 49 | 7.1 | 34 | 74 | 11.1 | 47 | 95 | 16.75 | 58 | 119 |
| 3.2 | 18 | 49 | 7.2 | 34 | 74 | 11.2 | 47 | 95 | 17 | 58 | 119 |
| 3.3 | 18 | 49 | 7.3 | 34 | 74 | 11.3 | 47 | 95 | 17.25 | 62 | 123 |
| 3.4 | 20 | 52 | 7.4 | 34 | 74 | 11.4 | 47 | 95 | 17.5 | 62 | 123 |
| 3.5 | 20 | 52 | 7.5 | 34 | 74 | 11.5 | 47 | 95 | 17.75 | 62 | 123 |
| 3.6 | 20 | 52 | 7.6 | 37 | 79 | 11.6 | 47 | 95 | 18 | 62 | 123 |
| 3.7 | 20 | 52 | 7.7 | 37 | 79 | 11.7 | 47 | 95 | 18.25 | 62 | 127 |
| 3.8 | 22 | 55 | 7.8 | 37 | 79 | 11.8 | 47 | 95 | 18.5 | 62 | 127 |
| 3.9 | 22 | 55 | 7.9 | 37 | 79 | 11.9 | 51 | 102 | 18.75 | 62 | 127 |
| 4 | 22 | 55 | 8 | 37 | 79 | 12 | 51 | 102 | 19 | 62 | 127 |
| 4.1 | 22 | 55 | 8.1 | 37 | 79 | 12.1 | 51 | 102 | 19.25 | 66 | 131 |
| 4.2 | 22 | 55 | 8.2 | 37 | 79 | 12.2 | 51 | 102 | 19.5 | 66 | 131 |
| 4.3 | 24 | 58 | 8.3 | 37 | 79 | 12.3 | 51 | 102 | 19.75 | 66 | 131 |
| 4.4 | 24 | 58 | 8.4 | 37 | 79 | 12.4 | 51 | 102 | 20 | 66 | 131 |
| 4.5 | 24 | 58 | 8.5 | 37 | 79 | 12.5 | 51 | 102 | | | |
| 4.6 | 24 | 58 | 8.6 | 40 | 84 | 12.6 | 51 | 102 | | | |
| 4.7 | 24 | 58 | 8.7 | 40 | 84 | 12.7 | 51 | 102 | | | |
| 4.8 | 26 | 62 | 8.8 | 40 | 84 | 12.8 | 51 | 102 | | | |
| 4.9 | 26 | 62 | 8.9 | 40 | 84 | 12.9 | 51 | 102 | | | |

DIN standard

ASME/ANSI standard

HSS EXTRA LONG DRILL BIT

DIN-1869 HSS DRILL BIT

EXTRA LONG HSS TWIST DRILL

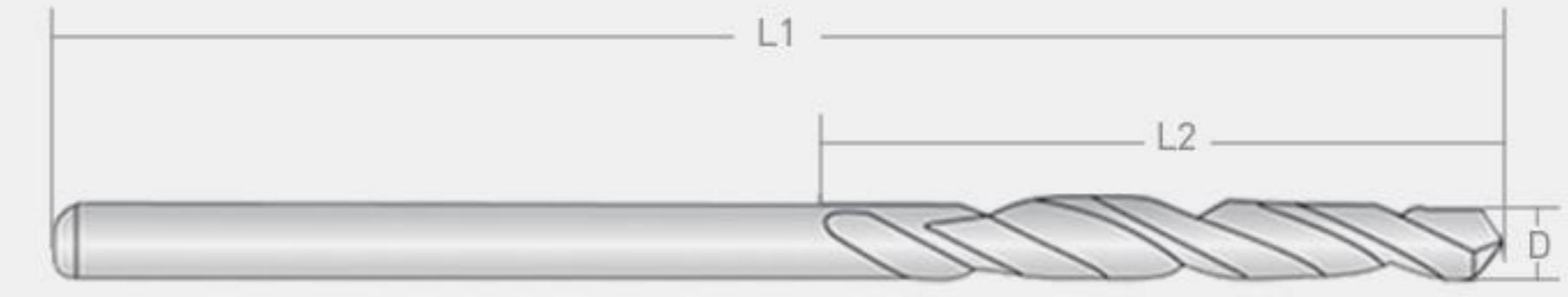

| DIN1869-I | | | D | L1 | L2 | D | L1 | L2 |
|-----------|-----|-----|-------|-----|-----|-------|-----|-----|
| 2.00 | 125 | 85 | 2.00 | 160 | 110 | 2.00 | 200 | 135 |
| 2.50 | 140 | 95 | 2.50 | 180 | 120 | 2.50 | 225 | 150 |
| 3.00 | 150 | 100 | 3.00 | 190 | 130 | 3.00 | 240 | 160 |
| 3.50 | 165 | 115 | 3.50 | 210 | 145 | 3.50 | 265 | 180 |
| 4.00 | 175 | 120 | 4.00 | 220 | 150 | 4.00 | 280 | 190 |
| 4.50 | 185 | 125 | 4.50 | 235 | 160 | 4.50 | 295 | 200 |
| 5.00 | 195 | 135 | 5.00 | 245 | 170 | 5.00 | 315 | 210 |
| 5.50 | 205 | 140 | 5.50 | 260 | 180 | 5.50 | 330 | 225 |
| 6.00 | 205 | 140 | 6.00 | 260 | 180 | 6.00 | 330 | 225 |
| 6.50 | 215 | 150 | 6.50 | 275 | 190 | 6.50 | 350 | 235 |
| 7.00 | 225 | 155 | 7.00 | 290 | 200 | 7.00 | 370 | 250 |
| 7.50 | 225 | 155 | 7.50 | 290 | 200 | 7.50 | 370 | 250 |
| 8.00 | 240 | 165 | 8.00 | 305 | 210 | 8.00 | 390 | 265 |
| 8.50 | 240 | 165 | 8.50 | 305 | 210 | 8.50 | 390 | 265 |
| 9.00 | 250 | 175 | 9.00 | 320 | 220 | 9.00 | 410 | 280 |
| 9.50 | 250 | 175 | 9.50 | 320 | 220 | 9.50 | 410 | 280 |
| 10.00 | 265 | 185 | 10.00 | 340 | 235 | 10.00 | 430 | 295 |
| 10.50 | 265 | 185 | 10.50 | 340 | 235 | 10.50 | 430 | 295 |
| 11.00 | 280 | 195 | 11.00 | 365 | 250 | 11.00 | 455 | 310 |
| 11.50 | 280 | 195 | 11.50 | 365 | 250 | 11.50 | 455 | 310 |
| 12.00 | 295 | 205 | 12.00 | 375 | 260 | 12.00 | 480 | 330 |
| 12.50 | 295 | 205 | 12.50 | 375 | 260 | 12.50 | 480 | 330 |
| 13.00 | 295 | 205 | 13.00 | 375 | 260 | 13.00 | 480 | 330 |

DIN standard

ASME/ANSI standard

HSS DOUBLE END DRILL BIT

HSS DOUBLE END DRILL

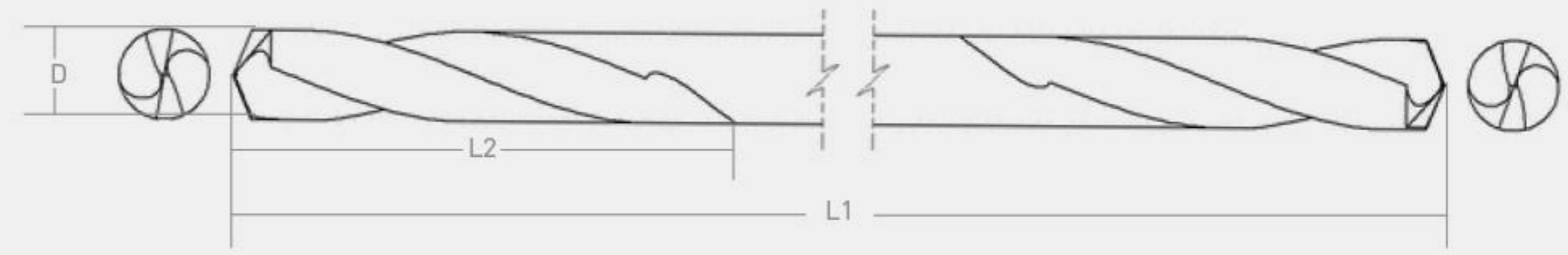

© PROCESS: FULLY-GROUND

© MATERIALS: HSS OR HSSCOBALTO APPLICATION



| D | L2 | L1 | D | L2 | L1 | D | L2 | L1 | D | L2 | L1 |
|------|------|------|------|------|------|------|------|------|-------|---------|------|
| 2.00 | 38.0 | 7.5 | 4.20 | 55.0 | 14.0 | 6.50 | 70.0 | 21.2 | 8.80 | 84.0 | 25.0 |
| 2.10 | 38.0 | 7.5 | 4.30 | 58.0 | 15.5 | 6.60 | 70.0 | 21.2 | 8.90 | 84.0 | 25.0 |
| 2.20 | 38.0 | 7.5 | 4.40 | 58.0 | 15.5 | 6.70 | 70.0 | 23.6 | 9.00 | 84.0 | 25.0 |
| 2.30 | 38.0 | 7.5 | 4.50 | 58.0 | 15.5 | 6.80 | 74.0 | 23.6 | 9.10 | 84.0 | 25.0 |
| 2.40 | 38.0 | 7.5 | 4.60 | 58.0 | 15.5 | 6.90 | 74.0 | 23.6 | 9.20 | 84.0 | 25.0 |
| 2.50 | 43.0 | 9.5 | 4.70 | 58.0 | 15.5 | 7.00 | 74.0 | 23.6 | 9.30 | 84.0 | 25.0 |
| 2.60 | 43.0 | 9.5 | 4.80 | 62.0 | 17.0 | 7.10 | 74.0 | 23.6 | 9.40 | 84.0 | 25.0 |
| 2.70 | 46.0 | 10.6 | 4.90 | 62.0 | 17.0 | 7.20 | 74.0 | 23.6 | 9.50 | 84.0 | 25.0 |
| 2.80 | 46.0 | 10.6 | 5.00 | 62.0 | 17.0 | 7.30 | 74.0 | 23.6 | 9.60 | 84.0 | 25.0 |
| 2.90 | 46.0 | 10.6 | 5.10 | 62.0 | 17.0 | 7.40 | 74.0 | 23.6 | 9.70 | 89.0 | 25.0 |
| 3.00 | 46.0 | 10.6 | 5.20 | 62.0 | 17.0 | 7.50 | 74.0 | 25.0 | 9.80 | 89.0 | 25.0 |
| 3.10 | 49.0 | 11.2 | 5.30 | 62.0 | 17.0 | 7.60 | 79.0 | 25.0 | 9.90 | 89.0 | 25.0 |
| 3.20 | 49.0 | 11.2 | 5.40 | 66.0 | 19.0 | 7.70 | 79.0 | 25.0 | 10.00 | 89.0 | 25.0 |
| 3.25 | 49.0 | 11.2 | 5.50 | 66.0 | 19.0 | 7.80 | 79.0 | 25.0 | 7/64" | 1-7/8" | 1/2" |
| 3.30 | 49.0 | 11.2 | 5.60 | 66.0 | 19.0 | 7.90 | 79.0 | 25.0 | 1/8" | 2" | 1/2" |
| 3.40 | 52.0 | 12.5 | 5.70 | 66.0 | 19.0 | 8.00 | 79.0 | 25.0 | 9/64" | 2" | 1/2" |
| 3.50 | 52.0 | 12.5 | 5.80 | 66.0 | 19.0 | 8.10 | 79.0 | 25.0 | 5/32" | 2-1/16" | 1/2" |
| 3.60 | 52.0 | 12.5 | 5.90 | 66.0 | 19.0 | 8.20 | 79.0 | 25.0 | 3/16" | 2-3/16" | 1/2" |
| 3.70 | 52.0 | 12.5 | 6.00 | 66.0 | 19.0 | 8.30 | 79.0 | 25.0 | 7/32" | 2-3/8" | 1/2" |
| 3.80 | 55.0 | 14.0 | 6.10 | 70.0 | 21.2 | 8.40 | 79.0 | 25.0 | 1/4" | 3-1/2" | 1/2" |
| 3.90 | 55.0 | 14.0 | 6.20 | 70.0 | 21.2 | 8.50 | 79.0 | 25.0 | 30# | 2" | 1/2" |
| 4.00 | 55.0 | 14.0 | 6.30 | 70.0 | 21.2 | 8.60 | 84.0 | 25.0 | 20# | 2-1/8" | 1/2" |
| 4.10 | 55.0 | 14.0 | 6.40 | 70.0 | 21.2 | 8.70 | 84.0 | 25.0 | 11# | 2-1/4" | 1/2" |

DIN standard

ASME/ANSI standard

HSS CENTER DRILL

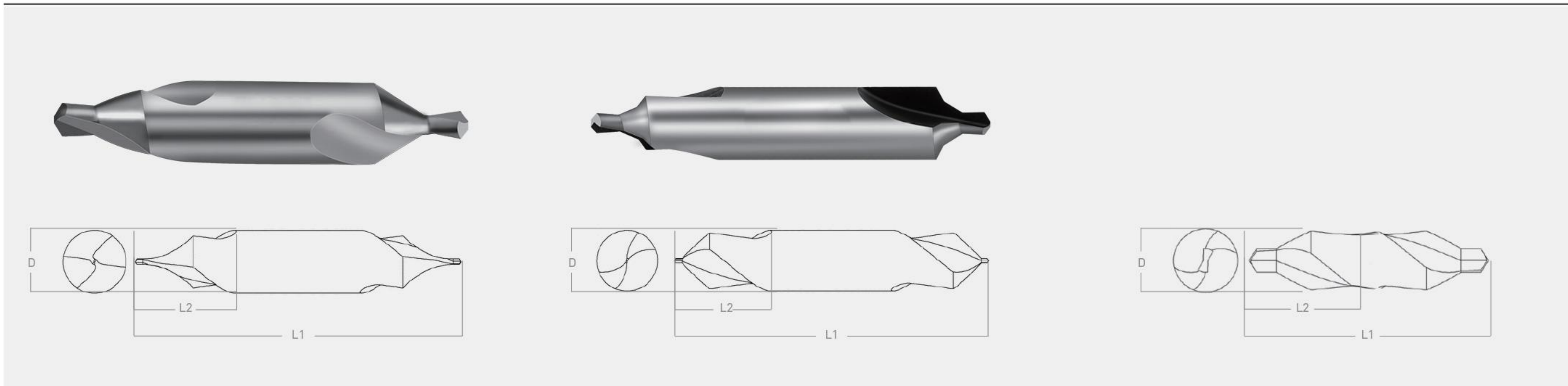

| Type A | | | | Type B | | | | Type R | | | | |
|--------|-------|--------|------|--------|-------|--------|------|--------|-------|--------|-------|-------|
| d | D | L | l | d | D | L | l | d | D | L | l | r |
| 1.00 | 3.15 | 33.50 | 1.90 | 1.00 | 4.00 | 37.50 | 1.90 | 1.00 | 3.15 | 33.50 | 3.00 | 2.50 |
| 1.25 | 3.15 | 33.50 | 1.90 | 1.25 | 5.00 | 42.00 | 2.20 | 1.25 | 3.15 | 33.50 | 3.35 | 3.15 |
| 1.60 | 4.00 | 37.50 | 2.80 | 1.60 | 6.30 | 47.00 | 2.80 | 1.60 | 4.00 | 37.50 | 4.25 | 4.00 |
| 2.00 | 5.00 | 42.00 | 3.30 | 2.00 | 8.00 | 52.50 | 3.30 | 2.00 | 5.00 | 42.00 | 5.30 | 5.00 |
| 2.50 | 6.30 | 47.00 | 4.10 | 2.50 | 10.00 | 59.00 | 4.10 | 2.50 | 6.30 | 47.00 | 6.70 | 6.30 |
| 3.15 | 8.00 | 52.00 | 4.90 | 3.15 | 11.20 | 63.00 | 4.90 | 3.15 | 8.00 | 52.00 | 8.50 | 8.00 |
| 4.00 | 10.00 | 59.00 | 6.20 | 4.00 | 14.00 | 70.00 | 6.20 | 4.00 | 10.00 | 59.00 | 10.60 | 10.00 |
| 5.00 | 12.50 | 66.00 | 7.50 | 5.00 | 18.00 | 78.00 | 7.50 | 5.00 | 12.50 | 66.00 | 13.20 | 12.50 |
| 6.30 | 16.00 | 74.00 | 9.20 | 6.30 | 20.00 | 83.00 | 9.20 | 6.30 | 16.00 | 74.00 | 17.00 | 16.00 |
| 8.00 | 20.00 | 80.00 | 11.5 | 8.00 | 22.00 | 100.00 | 11.5 | 8.00 | 20.00 | 80.00 | 21.20 | 20.00 |
| 10.00 | 22.00 | 100.00 | 14.2 | 10.00 | 28.00 | 125.00 | 14.2 | 10.00 | 22.00 | 100.00 | 26.50 | 25.00 |

DIN standard

ASME/ANSI standard

TWIST STEP DRILL BIT

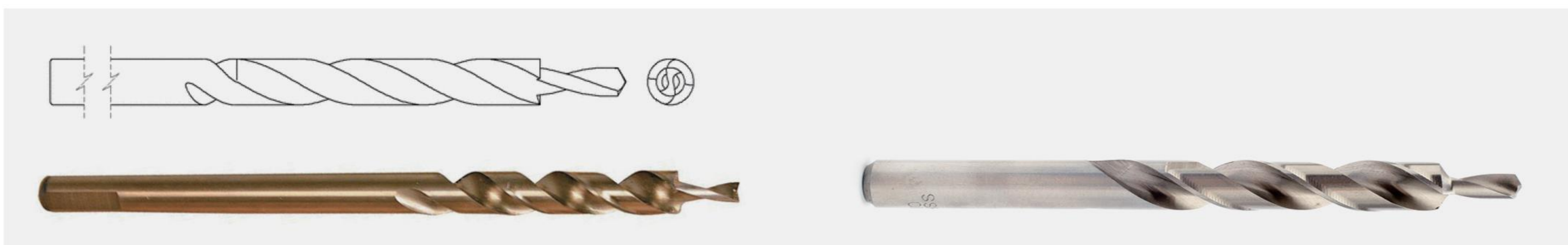

DIN standard

ASME/ANSI standard

HSS STEP DRILL BIT SPIRAL FLUT



- ◎ POINT CUT: SPLIT POINT DIN1412C
- ◎ POINT ANGLE: 118 DEGREES
- ◎ STEP ANGLE: 90 DEGREES
- ◎ SURFACE: BRIGHT / TIN COATED /BLACK / TIALA
- ◎ 3-1).METRIC STEP DRILL

| Drilling range/MM | Total length | Steps | Shank |
|-------------------|--------------|-------|-------|
| 3-12 | 65 | 10 | 6 |
| 3-14 | 65 | 13 | 6 |
| 4-12 | 65 | 5 | 6 |
| 4-12 | 65 | 9 | 6 |
| 4-20 | 75 | 9 | 8 |
| 4-22 | 72 | 10 | 8 |
| 4-24 | 76 | 11 | 8 |
| 4-30 | 100 | 14 | 10 |
| 4-32 | 89 | 15 | 10 |
| 4-39 | 107 | 13 | 10 |
| 5-35 | 78 | 13 | 13 |
| 6-18 | 70 | 7 | 8 |
| 6-20 | 72 | 8 | 8 |
| 6-30 | 93 | 13 | 10 |
| 6-35 | 78 | 13 | 13 |
| 6-36 | 86 | 10 | 12 |
| 6-38 | 100 | 12 | 10 |
| 10-20 | 77 | 11 | 9 |
| 14-24 | 78 | 6 | 10 |
| 20-30 | 82 | 11 | 12 |

Other size are available

| 3-2).ANSI step drill | | |
|----------------------|-------|-------|
| Drilling range /MM | Steps | Shank |
| 1/8"-1/2" | 7 | 1/4" |
| 1/8"-1/2" | 13 | 1/4" |
| 1/8"-3/8" | 5 | 1/4" |
| 1/4"-3/4" | 9 | 3/8" |
| 1/4"-7/8" | 11 | 3/8" |
| 1/4"-1-3/8" | 10 | 3/8" |
| 3/16"-1/2" | 6 | 1/4" |
| 3/16"-9/16" | 7 | 1/4" |
| 3/16"-7/8" | 12 | 3/8" |
| 9/16"-1" | 8 | 3/8" |
| 13/16"-1-3/8" | 10 | 1/2" |

Other size are available



DIN standard

ASME/ANSI standard

HSS STEP DRILL BIT STRAIGHT FLUT



© POINT CUT: SPLIT POINT DIN1412C
 © POINT ANGLE: 118 DEGREES
 © STEP ANGLE: 90 DEGREES

© SURFACE: BRIGHT / TIN COATED / BLACK / TIALA
 © 1-1).METRIC STEP DRILL

| Drilling range/MM | Total length | Steps | Shank |
|-------------------|--------------|-------|-------|
| 3-12 | 65 | 10 | 6 |
| 3-14 | 65 | 13 | 6 |
| 4-12 | 65 | 5 | 6 |
| 4-12 | 65 | 9 | 6 |
| 4-20 | 75 | 9 | 8 |
| 4-22 | 72 | 10 | 8 |
| 4-24 | 76 | 11 | 8 |
| 4-30 | 100 | 14 | 10 |
| 4-32 | 89 | 15 | 10 |
| 4-39 | 107 | 13 | 10 |
| 5-35 | 78 | 13 | 13 |
| 6-18 | 70 | 7 | 8 |
| 6-20 | 72 | 8 | 8 |
| 6-30 | 93 | 13 | 10 |
| 6-35 | 78 | 13 | 13 |
| 6-36 | 86 | 10 | 12 |
| 6-38 | 100 | 12 | 10 |
| 10-20 | 77 | 11 | 9 |
| 14-24 | 78 | 6 | 10 |
| 20-30 | 82 | 11 | 12 |

Other size are available

| 3-2).ANSI step drill | | |
|----------------------|-------|-------|
| Drilling range /MM | Steps | Shank |
| 1/8"-1/2" | 7 | 1/4" |
| 1/8"-1/2" | 13 | 1/4" |
| 1/8"-3/8" | 5 | 1/4" |
| 1/4"-3/4" | 9 | 3/8" |
| 1/4"-7/8" | 11 | 3/8" |
| 1/4"-1-3/8" | 10 | 3/8" |
| 3/16"-1/2" | 6 | 1/4" |
| 3/16"-9/16" | 7 | 1/4" |
| 3/16"-7/8" | 12 | 3/8" |
| 9/16"-1" | 8 | 3/8" |
| 13/16"-1-3/8" | 10 | 1/2" |

Other size are available



DIN standard

ASME/ANSI standard

HSS TUBE SHEET DRILL BIT

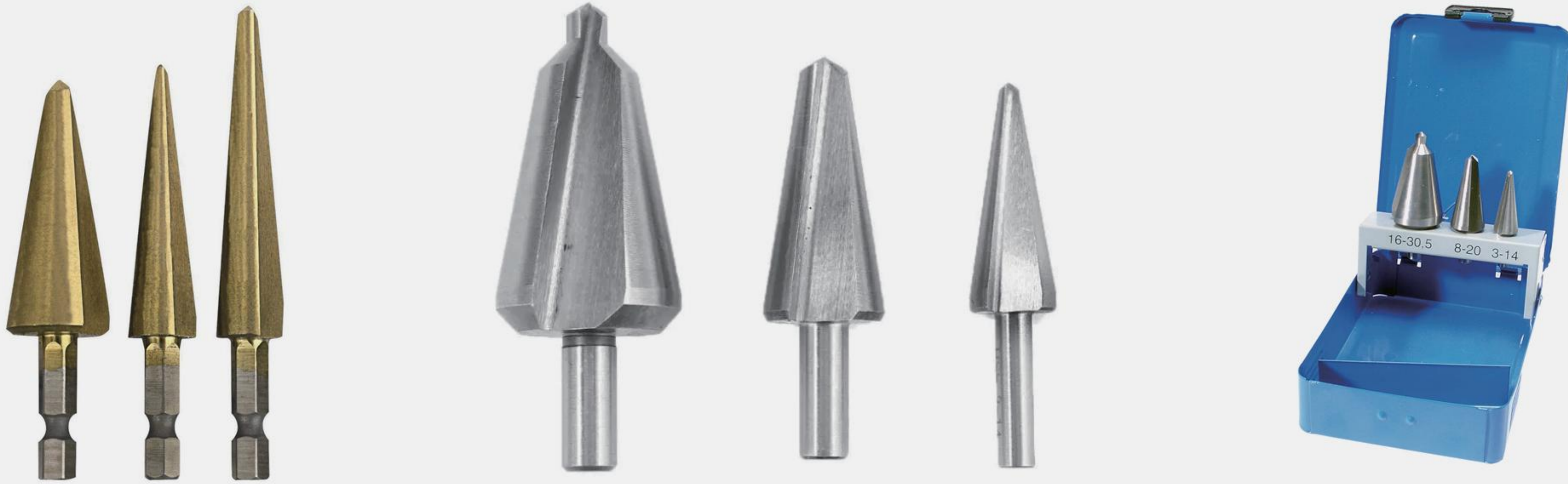

| | | | High | High | High | Cast | Cast | CuZn | CuZn | Aluminium | Thermo | Duro |
|--------------------|-------------------|-------|-----------|-----------|-----------|-----------|------------|------------|------------|-----------|-----------|------------|
| | | | carbon | carbon | carbon | iron | iron | alloy | alloy | alloy | plastic | plastic |
| | | | steel | steel | steel | | | brittle | brittle | tough | | |
| | Sheet thickness | | up to 4.0 | up to 4.0 | up to 4.0 | up to 4.0 | up to 4.0 | up to 4.0 | up to 4.0 | up to 4.0 | up to 4.0 | up to 4.0 |
| | 1VC=m/min | | 30 | 20 | 20 | 15 | 10 | 60 | 35 | 30 | 20 | 15 |
| | Cooling lubricant | | cutting | cutting | cutting | cutting | compressed | compressed | compressed | cutting | | compressed |
| | | | spray | spray | spray | spray | air | air | air | spray | Water | air |
| Drilling range/ MM | Total length | Shank | n=r.p.m | n=r.p.m | n=r.p.m | n=r.p.m | n=r.p.m | n=r.p.m | n=r.p.m | n=r.p.m | n=r.p.m | n=r.p.m |
| 3-14 | 65 | 6 | 3185-682 | 2123-445 | 2123-445 | 1592-341 | 1062-227 | 6369-1365 | 3715-796 | 3185-682 | 2123-455 | 1592-341 |
| 8-20 | 65 | 8 | 1911-478 | 1274-318 | 1274-318 | 955-239 | 637-159 | 3822-955 | 2229-557 | 1911-478 | 1274-318 | 955-239 |
| 16-30.5 | 65 | 9 | 597-313 | 398-209 | 398-209 | 299-157 | 199-104 | 1194-627 | 697-365 | 597-313 | 398-209 | 299-157 |
| 24-40 | 75 | 10 | 398-239 | 265-159 | 265-159 | 199-157 | 133-80 | 796-478 | 464-279 | 398-239 | 265-159 | 199-119 |
| 36-50 | 72 | 12 | 265-191 | 177-127 | 177-127 | 133-96 | 88-64 | 531-382 | 310-223 | 285-191 | 177-127 | 133-96 |
| 40-61 | 76 | 13 | 239-157 | 159-104 | 159-104 | 119-78 | 80-52 | 478-313 | 279-183 | 239-157 | 159-104 | 119-78 |
| 5-25.4 | 100 | 10 | 1911-376 | 1274-251 | 1274-251 | 955-188 | 637-125 | 3822-752 | 2229-439 | 1911-376 | 1274-251 | 955-188 |
| 4-31 | 89 | 9 | 1911-308 | 1274-205 | 1274-205 | 955-154 | 637-103 | 3822-616 | 2229-360 | 1911-308 | 1274-205 | 955-154 |
| 5-22.5 | 107 | 8 | 1911-425 | 1274-283 | 1274-283 | 955-212 | 637-142 | 3822-849 | 2229-495 | 1911425 | 1274-283 | 955-212 |

Other size set are available

DIN standard

ASME/ANSI standard

HSS SAW DRILL



| Inch | Metric(mm) | Flute length | L(Allover Length) |
|--------|------------|--------------|-------------------|
| 1/8" | 3 | 35 | 61 |
| 5/32" | 4 | 48 | 75 |
| 3/16" | 5 | 53 | 85 |
| 7/32" | 6 | 56 | 87 |
| 1/4" | 6.5 | 56 | 87 |
| 5/16" | 8 | 65 | 95 |
| — | 9 | 68 | 103 |
| 3/8" | 10 | 72 | 110 |
| 15/32" | 12 | 78 | 118 |
| 1/2" | 13 | 90 | 130 |

DIN standard

ASME/ANSI standard

HSS COUNTERSINK

© HSS DIN335 COUNTERSINK BITS



| D | L1 | d |
|------|------|-----|
| 4.3 | 40.0 | 4.0 |
| 4.8 | 40.0 | 4.0 |
| 5.0 | 40.0 | 4.0 |
| 5.3 | 40.0 | 4.0 |
| 5.8 | 45.0 | 5.0 |
| 6.0 | 45.0 | 5.0 |
| 6.3 | 45.0 | 5.0 |
| 7.0 | 50.0 | 6.0 |
| 7.3 | 50.0 | 6.0 |
| 8.0 | 50.0 | 6.0 |
| 8.3 | 50.0 | 6.0 |
| 9.4 | 50.0 | 6.0 |
| 10.0 | 50.0 | 6.0 |
| 10.1 | 50.0 | 6.0 |
| 11.5 | 56.0 | 8.0 |

| D | L1 | d |
|------|------|------|
| 12.4 | 56.0 | 8.0 |
| 13.4 | 56.0 | 8.0 |
| 15.0 | 60.0 | 10.0 |
| 16.5 | 60.0 | 10.0 |
| 16.5 | 60.0 | 10.0 |
| 19.0 | 63.0 | 10.0 |
| 20.5 | 63.0 | 10.0 |
| 23.0 | 67.0 | 10.0 |
| 25.0 | 67.0 | 10.0 |
| 26.0 | 71.0 | 12.0 |
| 28.0 | 71.0 | 12.0 |
| 30.0 | 71.0 | 12.0 |
| 31.0 | 71.0 | 12.0 |
| 37.0 | 90.0 | 12.0 |
| 40.0 | 90.0 | 15.0 |

DIN standard

ASME/ANSI standard

HSS COUNTERSINK

© HSS DIN335 COUNTERSINK BITS EUROPE TYPE



| For thread | D | L1 | d |
|------------|-------|-----|-------|
| 1-4 | 6.35 | 45 | 6.35 |
| 2-5 | 10.00 | 45 | 8.00 |
| 5-10 | 14.00 | 48 | 8.00 |
| 10-15 | 21.00 | 65 | 10.00 |
| 15-20 | 28.00 | 85 | 12.00 |
| 20-25 | 35.00 | 102 | 15.00 |
| 25-30 | 44.00 | 115 | 15.00 |
| 30-35 | 48.00 | 127 | 15.00 |
| 35-40 | 53.00 | 136 | 15.00 |
| 40-50 | 64.00 | 166 | 18.00 |

© HSS COUNTERSINK BITS INCH SIZES



| For thread | D | L1 | d |
|------------|----------|--------|------|
| #0 | 15/64" | 1-3/4" | 1/4" |
| #1 | 13/32" | 1-3/4" | 1/4" |
| #2 | 17/32" | 2" | 1/4" |
| #3 | 25/32" | 2-3/4" | 1/2" |
| #4 | 1-1/16" | 3" | 1/2" |
| #5 | 1-15/32" | 3-3/4" | 1/2" |
| #6 | 1-3/4" | 4" | 5/8" |
| #7 | 2" | 4-3/8" | 5/8" |
| #8 | 2-1/2" | 4-3/4" | 3/4" |

© HSS SINGLEFLUTE COUNTERSINK BITS



| For thread | D | L1 | d |
|------------|---------|--------|-------|
| 3/16" | 3/4" | 1-1/2" | 3/16" |
| 1/4" | 3/4" | 2" | 1/4" |
| 5/16" | 1" | 2" | 1/4" |
| 3/8" | 1" | 2" | 1/4" |
| 5/2" | 1" | 2" | 1/4" |
| 5/8 | 1-1/8" | 2-3/4" | 3/8" |
| 5/8" | 1-1/8" | 2-3/4" | 1/2" |
| 3/4" | 1-5/16" | 2-3/4" | 3/8" |
| 3/4" | 1-5/16" | 2-3/4" | 1/2" |
| 7/8" | 1-5/16" | 2-3/4" | 1/2" |
| 1" | 1-5/16" | 2-3/4" | 1/2" |
| 1-1/4" | 1-5/8" | 3-3/8" | 3/4" |
| 1-1/2" | 1-5/8" | 3-1/2" | 3/4" |
| 2" | 1-5/8" | 3-3/4" | 3/4" |

STRAIGHT SHANK

ASME HSS DRILL BIT

JOBBER LENGTH



| D | D | L2 | L1 | D | D | L2 | L1 | D | D | L2 | L1 |
|-------|-------|---------|-------|-----|-------|--------|-------|-----|-------|---------|-------|
| 1/16 | .0625 | 7/8 | 1-7/8 | #16 | .1770 | 2-3/16 | 3-3/8 | #60 | .0400 | 11/16 | 1-5/8 |
| 5/64 | .0781 | 1 | 2 | #17 | .1730 | 2-3/16 | 3-3/8 | A | .2340 | 2-5/8 | 3-7/8 |
| 3/32 | .0938 | 1-1/4 | 2-1/4 | #18 | .1695 | 2-1/8 | 3-1/4 | B | .2380 | 2-3/4 | 4 |
| 7/64 | .1094 | 1-1/2 | 2-5/8 | #19 | .1660 | 2-1/8 | 3-1/4 | C | .2420 | 2-3/4 | 4 |
| 1/8 | .1250 | 1-5/8 | 2-3/4 | #20 | .1610 | 2-1/8 | 3-1/4 | D | .2460 | 2-3/4 | 4 |
| 9/64 | .1406 | 1-3/4 | 2-7/8 | #21 | .1590 | 2-1/8 | 3-1/4 | E | .2500 | 2-3/4 | 4 |
| 5/32 | .2188 | 2 | 3-1/8 | #22 | .1570 | 2 | 3-1/8 | F | .2570 | 2-7/8 | 4-1/8 |
| 11/64 | .1719 | 2-1/8 | 3-1/4 | #23 | .1540 | 2 | 3-1/8 | G | .2610 | 2-7/8 | 4-1/8 |
| 3/16 | .1875 | 2-5/16 | 3-1/2 | #24 | .1520 | 2 | 3-1/8 | H | .2660 | 2-7/8 | 4-1/8 |
| 13/64 | .2031 | 2-7/16 | 3-5/8 | #25 | .1495 | 1-7/8 | 3 | I | .2720 | 2-7/8 | 4-1/8 |
| 7/32 | .2188 | 2-1/2 | 3-3/4 | #26 | .1470 | 1-7/8 | 3 | J | .2770 | 2-7/8 | 4-1/8 |
| 15/64 | .2344 | 2-5/8 | 3-3/7 | #27 | .1440 | 1-7/8 | 3 | K | .2810 | 2-15/16 | 4-1/4 |
| 1/4 | .2500 | 2-3/4 | 4 | #28 | .1405 | 1-3/4 | 2-7/8 | L | .2900 | 2-15/16 | 4-1/4 |
| 17/64 | .2656 | 2-7/8 | 4-1/8 | #29 | .1360 | 1-3/4 | 2-7/8 | M | .2950 | 3-1/16 | 4-3/8 |
| 9/32 | .2812 | 2-15/16 | 4-1/4 | #30 | .1285 | 1-5/8 | 2-3/4 | N | .3020 | 3-1/16 | 4-3/8 |
| 19/64 | .2969 | 3-1/16 | 4-3/8 | #31 | .1200 | 1-5/8 | 2-3/4 | O | .3160 | 3-3/16 | 4-1/2 |
| 5/16 | .3125 | 3-3/16 | 4-1/2 | #32 | .1160 | 1-5/8 | 2-3/4 | P | .3230 | 3-5/16 | 4-5/8 |
| 21/64 | .3281 | 3-5/16 | 4-3/4 | #33 | .1130 | 1-1/2 | 2-5/8 | Q | .3320 | 3-7/16 | 4-3/4 |
| 11/32 | .3438 | 3-7/16 | 4-5/8 | #34 | .1110 | 1-1/2 | 2-5/8 | R | .3390 | 3-7/16 | 4-3/4 |
| 23/64 | .3594 | 3-1/2 | 4-7/8 | #35 | .1100 | 1-1/2 | 2-5/8 | S | .3480 | 3-1/2 | 4-7/8 |
| 3/8 | .3750 | 3-5/8 | 5 | #36 | .1065 | 1-7/16 | 2-1/2 | I | .3580 | 3-1/2 | 4-7/8 |
| 25/64 | .3906 | 3-3/4 | 5-1/8 | #37 | .1040 | 1-7/16 | 2-1/2 | U | .3680 | 3-5/8 | 5 |
| 13/32 | .4062 | 3-7/8 | 5-1/4 | #38 | .1015 | 1-7/16 | 2-1/2 | V | .3770 | 3-5/8 | 5 |
| 27/64 | .4219 | 3-15/16 | 5-3/8 | #39 | .0995 | 1-3/8 | 2-3/8 | W | .3860 | 3-3/4 | 5-1/8 |
| 7/16 | .4375 | 4-1/16 | 5-1/2 | #40 | .0980 | 1-3/8 | 2-3/8 | X | .3970 | 3-3/4 | 5-1/8 |
| 29/64 | .4531 | 4-3/16 | 5-5/8 | #41 | .0960 | 1-3/8 | 2-3/8 | Y | .4040 | 3-7/8 | 5-1/4 |
| 15/32 | .4688 | 4-5/16 | 5-3/4 | #42 | .0935 | 1-1/4 | 2-1/4 | Z | .4130 | 3-7/8 | 5-1/4 |
| 31/64 | .4844 | 4-3/8 | 5-7/8 | #43 | .0890 | 1-1/4 | 2-1/4 | | | | |
| 1/2 | .5000 | 4-1/2 | 6 | #44 | .0860 | 1-1/8 | 2-1/8 | | | | |
| #1 | .2280 | 2-5/8 | 3-7/8 | #45 | .0820 | 1-1/8 | 2-1/8 | | | | |
| #2 | .2210 | 2-5/8 | 3-7/8 | #46 | .0810 | 1-1/8 | 2-1/8 | | | | |
| #3 | .2130 | 2-1/2 | 3-3/4 | #47 | .0785 | 1 | 2 | | | | |
| #4 | .2090 | 2-1/2 | 3-3/4 | #48 | .0760 | 1 | 2 | | | | |
| #5 | .2055 | 2-1/2 | 3-3/4 | #49 | .0730 | 1 | 2 | | | | |
| #6 | .2040 | 2-1/2 | 3-3/4 | #50 | .0700 | 1 | 2 | | | | |
| #7 | .2010 | 2-7/16 | 3-5/8 | #51 | .0670 | 1 | 2 | | | | |
| #8 | .1990 | 2-7/16 | 3-5/8 | #52 | .0635 | 7/8 | 1-7/8 | | | | |
| #9 | .1960 | 2-7/16 | 3-5/8 | #53 | .0595 | 7/8 | 1-7/8 | | | | |
| #10 | .1935 | 2-7/16 | 3-5/8 | #54 | .0550 | 7/8 | 1-7/8 | | | | |
| #11 | .1910 | 2-5/16 | 3-1/2 | #55 | .0520 | 7/8 | 1-7/8 | | | | |
| #12 | .1890 | 2-5/16 | 3-1/2 | #56 | .0465 | 3/4 | 1-3/4 | | | | |
| #13 | .1850 | 2-5/16 | 3-1/2 | #57 | .0430 | 3/4 | 1-3/4 | | | | |
| #14 | .1820 | 2-3/16 | 3-3/8 | #58 | .0420 | 11/16 | 1-5/8 | | | | |
| #15 | .1800 | 2-3/16 | 3-3/8 | #59 | .0410 | 11/16 | 1-5/8 | | | | |

3/8 REDUCED SHANK



| D | D | L2 | L1 |
|-------|-------|---------|-------|
| 25/64 | .3906 | 3-3/4 | 5-1/8 |
| 13/32 | .4062 | 3-7/8 | 5-1/4 |
| 27/64 | .4219 | 3-15/16 | 5-3/8 |
| 7/16 | .4375 | 4-1/6 | 5-1/2 |
| 29/64 | .4531 | 4-3/16 | 5-5/8 |
| 15/32 | .4688 | 4-5/16 | 5-3/4 |
| 31/64 | .4844 | 4-3/8 | 5-7/8 |
| 1/2 | .5000 | 4-1/2 | 6 |

STRAIGHT SHANK

ASME-HSS DRILL BIT

SCREW MACHINE LENGTH



| D | D | L2 | L1 | D | D | L2 | L1 | D | D | L2 | L1 |
|-------|-------|---------|---------|-----|-------|--------|---------|-----|-------|---------|---------|
| 3/64 | .0469 | 1/2 | 1-3/8 | #10 | .1935 | 1-3/16 | 2-1/4 | #49 | .0730 | 11/16 | 1-11/16 |
| 1/16 | .0625 | 5/8 | 1-5/8 | #11 | .1910 | 1-3/16 | 2-1/4 | #50 | .0700 | 11/16 | 1-11/16 |
| 5/64 | .0781 | 11/16 | 1-11/16 | #12 | .1890 | 1-3/16 | 2-1/4 | #51 | .0670 | 11/16 | 1-11/16 |
| 3/32 | .0938 | 3/4 | 1-3/4 | #13 | .1850 | 1-1/8 | 2-3/16 | #52 | .0635 | 11/16 | 1-11/16 |
| 7/64 | .1094 | 13/16 | 1-13/16 | #14 | .1820 | 1-1/8 | 2-3/16 | #53 | .0595 | 5/8 | 1-5/8 |
| 1/8 | .1250 | 7/8 | 1-7/8 | #15 | .1800 | 1-1/8 | 2-3/16 | #54 | .0550 | 5/8 | 1-5/8 |
| 9/64 | .1406 | 15/16 | 1-15/16 | #16 | .1770 | 1-1/8 | 2-3/16 | #55 | .0520 | 5/8 | 1-5/8 |
| 5/32 | .1562 | 1 | 2-1/16 | #17 | .1730 | 1-1/8 | 2-3/16 | #56 | .0465 | 1/2 | 1-3/8 |
| 11/64 | .1719 | 1-1/16 | 2-1/8 | #18 | .1695 | 1-1/16 | 2-1/8 | #57 | .0430 | 1/2 | 1-3/8 |
| 3/16 | .1875 | 1-1/8 | 2-3/16 | #19 | .1660 | 1-1/16 | 2-1/8 | #58 | .0420 | 1/2 | 1-3/8 |
| 13/64 | .2031 | 1-3/16 | 3-1/4 | #20 | .1610 | 1-1/16 | 2-1/8 | #59 | .0410 | 1/2 | 1-3/8 |
| 7/32 | .2188 | 1-1/4 | 2-3/8 | #21 | .1590 | 1-1/16 | 2-1/8 | #60 | .0400 | 1/2 | 1-3/8 |
| 15/64 | .2344 | 1-5/16 | 2-7/16 | #22 | .1570 | 1-1/16 | 2-1/8 | A | .2340 | 1-15/16 | 2-7/16 |
| 1/4 | .2500 | 1-3/8 | 2-1/2 | #23 | .1540 | 1 | 2-1/16 | B | .2380 | 1-3/8 | 2-1/2 |
| 17/64 | .2656 | 1-7/16 | 2-5/8 | #24 | .1520 | 1 | 2-1/16 | C | .2420 | 1-3/8 | 2-1/2 |
| 9/32 | .2812 | 1-1/2 | 2-11/16 | #25 | .1495 | 1 | 2-1/16 | D | .2460 | 1-3/8 | 2-1/2 |
| 19/64 | .2969 | 1-9/16 | 2-3/4 | #26 | .1470 | 1 | 2-1/16 | E | .2500 | 1-3/8 | 2-1/2 |
| 5/16 | .3125 | 1-5/8 | 2-13/16 | #27 | .1440 | 1 | 2-1/16 | F | .2570 | 1-7/16 | 2-5/8 |
| 21/64 | .3281 | 1-11/16 | 2-15/16 | #28 | .1405 | 15/16 | 1-15/16 | G | .2610 | 1-7/16 | 2-5/8 |
| 11/32 | .3438 | 1-11/16 | 3 | #29 | .1360 | 15/16 | 1-15/16 | H | .2660 | 1-1/2 | 2-11/16 |
| 23/64 | .3594 | 1-3/4 | 3-1/16 | #30 | .1285 | 15/16 | 1-15/16 | I | .2720 | 1-1/2 | 2-11/16 |
| 3/8 | .3750 | 1-13/16 | 3-1/8 | #31 | .1200 | 7/8 | 1-7/8 | J | .2770 | 1-1/2 | 2-11/16 |
| 25/64 | .3906 | 1-7/8 | 3-1/4 | #32 | .1160 | 7/8 | 1-7/8 | K | .2810 | 1-1/2 | 2-11/16 |
| 13/32 | .4062 | 1-15/16 | 3-5/16 | #33 | .1130 | 7/8 | 1-7/8 | L | .2900 | 1-9/16 | 2-3/4 |
| 27/64 | .4219 | 2 | 3-3/8 | #34 | .1110 | 7/8 | 1-7/8 | M | .2950 | 1-9/16 | 2-3/4 |
| 7/16 | .4375 | 2-1/16 | 3-7/16 | #35 | .1100 | 7/8 | 1-7/8 | N | .3020 | 1-5/8 | 2-13/16 |
| 29/64 | .4531 | 2-1/8 | 3-9/16 | #36 | .1065 | 13/16 | 1-13/16 | O | .3160 | 1-11/16 | 2-15/16 |
| 15/32 | .4688 | 2-1/8 | 3-5/8 | #37 | .1040 | 13/16 | 1-13/16 | P | .3230 | 1-11/16 | 2-15/16 |
| 31/64 | .4844 | 2-3/16 | 3-11/16 | #38 | .1015 | 13/16 | 1-13/16 | Q | .3320 | 1-11/16 | 3 |
| 1/2 | .5000 | 2-1/4 | 3-3/4 | #39 | .0995 | 13/16 | 1-13/16 | R | .3390 | 1-11/16 | 3 |
| #1 | .2280 | 1-5/16 | 2-7/16 | #40 | .0980 | 13/16 | 1-13/16 | S | .3480 | 1-3/4 | 3-1/16 |
| #2 | .2210 | 1-5/16 | 2-7/16 | #41 | .0960 | 13/16 | 1-13/16 | T | .3580 | 1-3/4 | 3-1/16 |
| #3 | .2130 | 1-1/4 | 2-3/8 | #42 | .0935 | 3/4 | 1-3/4 | U | .3680 | 1-13/16 | 3-3/8 |
| #4 | .2090 | 1-1/4 | 2-3/8 | #43 | .0890 | 3/4 | 1-3/4 | V | .3770 | 1-7/8 | 3-1/4 |
| #5 | .2055 | 1-1/4 | 2-3/8 | #44 | .8660 | 3/4 | 1-3/4 | W | .3860 | 1-7/8 | 3-1/4 |
| #6 | .2040 | 1-1/4 | 2-3/8 | #45 | .0820 | 3/4 | 1-3/4 | X | .3970 | 1-15/16 | 3-15/16 |
| #7 | .2010 | 1-3/16 | 2-1/4 | #46 | .0810 | 3/4 | 1-3/4 | Y | .4040 | 1-15/16 | 3-15/16 |
| #8 | .1990 | 1-3/16 | 2-1/4 | #47 | .0785 | 11/16 | 1-11/16 | Z | .4130 | 2 | 3-3/8 |
| #9 | .1960 | 1-3/16 | 2-1/4 | #48 | .0760 | 11/16 | 1-11/16 | | | | |

STRAIGHT SHANK

ASME-HSS DRILL BIT

TAPER LENGTH



| D | D | L2 | L1 | D | D | L2 | L1 | D | D | L2 | L1 |
|-------|-------|-------|-------|-----|-------|-------|-------|-----|-------|-------|-------|
| 1/64 | .0156 | 5/16 | 1-1/2 | #9 | .1960 | 3-5/8 | 6 | #49 | .0730 | 2 | 3-3/4 |
| 1/32 | .0312 | 3/4 | 2 | #10 | .1935 | 3-5/8 | 6 | #50 | .0700 | 2 | 3-3/4 |
| 3/64 | .0469 | 1-1/8 | 2-1/4 | #11 | .1910 | 3-5/8 | 6 | #51 | .0670 | 2 | 3-3/4 |
| 1/16 | .0625 | 1-3/4 | 3 | #12 | .1890 | 3-5/8 | 6 | #52 | .0635 | 2 | 3-3/4 |
| 5/64 | .0781 | 2 | 3-3/4 | #13 | .1850 | 3-3/8 | 5-3/4 | #53 | .0595 | 1-3/4 | 3 |
| 3/32 | .0938 | 2-1/4 | 4-1/4 | #14 | .1820 | 3-3/8 | 5-3/4 | #54 | .0550 | 1-3/4 | 3 |
| 7/64 | .1094 | 2-1/2 | 4-5/8 | #15 | .1800 | 3-3/8 | 5-3/4 | #55 | .0520 | 1-3/4 | 3 |
| 1/8 | .1250 | 2-3/4 | 5-1/8 | #16 | .1770 | 3-3/8 | 5-3/4 | #56 | .0465 | 1-1/8 | 2-1/4 |
| 9/64 | .1406 | 3 | 5-3/8 | #17 | .1730 | 3-3/8 | 5-3/4 | #57 | .0430 | 1-1/8 | 2-1/4 |
| 5/32 | .1562 | 3 | 5-3/8 | #18 | .1695 | 3-3/8 | 5-3/4 | #58 | .0420 | 1-1/8 | 2-1/4 |
| 11/64 | .1719 | 3-3/8 | 5-3/4 | #19 | .1660 | 3-3/8 | 5-3/4 | #59 | .0410 | 1-1/8 | 2-1/4 |
| 3/16 | .1875 | 3-3/8 | 5-3/4 | #20 | .1610 | 3-3/8 | 5-3/4 | #60 | .0400 | 1-1/8 | 2-1/4 |
| 13/64 | .2031 | 3-5/8 | 6 | #21 | .1590 | 3-3/8 | 5-3/4 | A | .2340 | 3-3/4 | 6-1/8 |
| 7/32 | .2188 | 3-5/8 | 6 | #22 | .1570 | 3-3/8 | 5-3/4 | B | .2380 | 3-3/4 | 6-1/8 |
| 15/64 | .2344 | 3-3/4 | 6-1/8 | #23 | .1540 | 3 | 5-3/8 | C | .2420 | 3-3/4 | 6-1/8 |
| 1/4 | .2500 | 3-3/4 | 6-1/8 | #24 | .1520 | 3 | 5-3/8 | D | .2460 | 3-3/4 | 6-1/8 |
| 17/64 | .2650 | 3-7/8 | 6-1/4 | #25 | .1495 | 3 | 5-3/8 | E | .2500 | 3-3/4 | 6-1/8 |
| 9/32 | .2812 | 3-7/8 | 6-1/4 | #26 | .1470 | 3 | 5-3/8 | F | .2570 | 3-7/8 | 6-1/4 |
| 19/64 | .2969 | 4 | 6-3/8 | #27 | .1440 | 3 | 5-3/8 | G | .2610 | 3-7/8 | 6-1/4 |
| 5/16 | .3125 | 4 | 6-3/8 | #28 | .1405 | 3 | 5-3/8 | H | .2660 | 3-7/8 | 6-1/4 |
| 21/64 | .3281 | 4-1/8 | 6-1/2 | #29 | .1360 | 3 | 5-3/8 | I | .2720 | 3-7/8 | 6-1/4 |
| 11/32 | .3438 | 4-1/8 | 6-1/2 | #30 | .1285 | 3 | 5-3/8 | J | .2770 | 3-7/8 | 6-1/4 |
| 23/64 | .3594 | 4-1/4 | 6-3/4 | #31 | .1200 | 2-3/4 | 5-1/8 | K | .2810 | 3-7/8 | 6-1/4 |
| 3/8 | .3750 | 4-1/4 | 6-3/4 | #32 | .1160 | 2-3/4 | 5-1/8 | L | .2900 | 4 | 6-3/8 |
| 25/64 | .3906 | 4-3/8 | 7 | #33 | .1130 | 2-3/4 | 5-1/8 | M | .2950 | 4 | 6-3/8 |
| 13/32 | .4062 | 4-3/8 | 7 | #34 | .1110 | 2-3/4 | 5-1/8 | N | .3020 | 4 | 6-3/8 |
| 27/64 | .4219 | 4-5/8 | 7-1/4 | #35 | .1100 | 2-3/4 | 5-1/8 | O | .3160 | 4-1/8 | 6-1/2 |
| 7/16 | .4375 | 4-5/8 | 7-1/4 | #36 | .1065 | 2-1/2 | 4-5/8 | P | .3230 | 4-1/8 | 6-1/2 |
| 29/64 | .4531 | 4-3/4 | 7-1/2 | #37 | .1040 | 2-1/2 | 4-5/8 | Q | .3320 | 4-1/8 | 6-1/2 |
| 15/32 | .4688 | 4-3/4 | 7-1/2 | #38 | .1015 | 2-1/2 | 4-5/8 | R | .3390 | 4-1/8 | 6-1/2 |
| 31/64 | .4844 | 4-3/4 | 7-3/4 | #39 | .0995 | 2-1/2 | 4-5/8 | S | .3480 | 4-1/4 | 6-3/4 |
| 1/2 | .5000 | 4-3/4 | 7-3/4 | #40 | .0980 | 2-1/2 | 4-5/8 | T | .3580 | 4-1/4 | 6-3/4 |
| #1 | .2280 | 3-3/4 | 6-1/8 | #41 | .0960 | 2-1/2 | 4-5/8 | U | .3680 | 4-1/4 | 6-3/4 |
| #2 | .2210 | 3-3/4 | 6-1/8 | #42 | .0935 | 2-1/4 | 4-1/4 | V | .3770 | 4-3/8 | 7 |
| #3 | .2130 | 3-5/8 | 6 | #43 | .0890 | 2-1/4 | 4-1/4 | W | .3860 | 4-3/8 | 7 |
| #4 | .2090 | 3-5/8 | 6 | #44 | .0860 | 2-1/4 | 4-1/4 | X | .3970 | 4-3/8 | 7 |
| #5 | .2055 | 3-5/8 | 6 | #45 | .0820 | 2-1/4 | 4-1/4 | Y | .4040 | 4-3/8 | 7 |
| #6 | .2040 | 3-5/8 | 6 | #46 | .0810 | 2-1/4 | 4-1/4 | Z | .4130 | 4-5/8 | 7-1/4 |
| #7 | .2010 | 3-5/8 | 6 | #47 | .0785 | 2-1/4 | 4-1/4 | | | | |
| #8 | .1990 | 3-5/8 | 6 | #48 | .0760 | 2 | 3-3/4 | | | | |

DIN standard

ASME/ANSI standard

STRAIGHT SHANK

ASME-HSS DRILL BIT

AIRCRAFT EXTENSION



| D | D | L2 | L1 | D | D | L2 | L1 | D | D | L2 | L1 |
|-------|-------|-------|----|-------|-------|---------|----|-------|-------|--------|----|
| 1/16 | .0625 | 7/8 | 6 | 3/16 | .1875 | 2-5/16 | 6 | 5/16 | .3125 | 3-3/16 | 6 |
| 5/64 | .0781 | 1 | 6 | 13/64 | .2031 | 2-7/16 | 6 | 21/64 | .3281 | 3-5/16 | 6 |
| 3/32 | .0938 | 1-1/4 | 6 | 7/32 | .2188 | 2-1/2 | 6 | 11/32 | .3438 | 3-7/16 | 6 |
| 7/64 | .1094 | 1-1/2 | 6 | 15/64 | .2344 | 2-5/8 | 6 | 23/64 | .3594 | 3-1/2 | 6 |
| 1/8 | .1250 | 1-5/8 | 6 | 1/4 | .2500 | 2-3/4 | 6 | 3/8 | .3750 | 3-5/8 | 6 |
| 9/64 | .1406 | 1-3/4 | 6 | 17/64 | .2656 | 2-7/8 | 6 | 7/16 | .4375 | 4-1/16 | 6 |
| 5/32 | .1562 | 2 | 6 | 9/32 | .2812 | 2-15/16 | 6 | 1/2 | .5000 | 4-1/2 | 6 |
| 11/64 | .1719 | 2-1/8 | 6 | 19/64 | .2969 | 3-1/16 | 6 | | | | |

ASME-HSS DRILL BIT

AIRCRAFT EXTENSION



| D | D | L2 | L1 | D | D | L2 | L1 | D | D | L2 | L1 |
|-------|-------|-------|----|-------|-------|---------|----|-------|-------|--------|----|
| 1/16 | .0625 | 7/8 | 12 | 3/16 | .1875 | 2-5/16 | 12 | 5/16 | .3125 | 3-3/16 | 12 |
| 5/64 | .0781 | 1 | 12 | 13/64 | .2031 | 2-7/16 | 12 | 21/64 | .3281 | 3-5/16 | 12 |
| 3/32 | .0938 | 1-1/4 | 12 | 7/32 | .2188 | 2-1/2 | 12 | 11/32 | .3438 | 3-7/16 | 12 |
| 7/64 | .1094 | 1-1/2 | 12 | 15/64 | .2344 | 2-5/8 | 12 | 23/64 | .3594 | 3-1/2 | 12 |
| 1/8 | .1250 | 1-5/8 | 12 | 1/4 | .2500 | 2-3/4 | 12 | 3/8 | .3750 | 3-5/8 | 12 |
| 9/64 | .1406 | 1-3/4 | 12 | 17/64 | .2656 | 2-7/8 | 12 | 7/16 | .4375 | 4-1/16 | 12 |
| 5/32 | .1562 | 2 | 12 | 9/32 | .2812 | 2-15/16 | 12 | 1/2 | .5000 | 4-1/2 | 12 |
| 11/64 | .1719 | 2-1/8 | 12 | 19/64 | .2969 | 3-1/16 | 12 | | | | |

DIN standard

ASME/ANSI standard

STRAIGHT SHANK

ASME-HSS DRILL BIT

1/2" SHANK, SILVER&DEMING



| D | D | L2 | L1 | D | D | L2 | L1 | D | D | L2 | L1 |
|-------|-------|----|----|-------|-------|----|----|--------|--------|----|----|
| 33/64 | .5156 | 3 | 6 | 3/4 | .7500 | 3 | 6 | 63/64 | .9844 | 3 | 6 |
| 17/32 | .5312 | 3 | 6 | 49/64 | .7656 | 3 | 6 | 1 | 1.0000 | 3 | 6 |
| 35/64 | .5469 | 3 | 6 | 23/32 | .7812 | 3 | 6 | 1-1/32 | 10,312 | 3 | 6 |
| 9/16 | .5625 | 3 | 6 | 51/64 | .7969 | 3 | 6 | 1-1/16 | 1.0625 | 3 | 6 |
| 37/64 | .5781 | 3 | 6 | 13/16 | .8125 | 3 | 6 | 1-3/32 | 1.0938 | 3 | 6 |
| 19/32 | .5938 | 3 | 6 | 53/64 | .8281 | 3 | 6 | 1-1/8 | 1.1250 | 3 | 6 |
| 39/64 | .6094 | 3 | 6 | 27/32 | .8438 | 3 | 6 | 1-5/32 | 1.1562 | 3 | 6 |
| 5/8 | .6250 | 3 | 6 | 55/64 | .8594 | 3 | 6 | 1-3/16 | 1.1875 | 3 | 6 |
| 41/64 | .6406 | 3 | 6 | 7/8 | .8750 | 3 | 6 | 1-7/32 | 1.2188 | 3 | 6 |
| 21/32 | .6562 | 3 | 6 | 57/64 | .8906 | 3 | 6 | 1-1/4 | 1.2500 | 3 | 6 |
| 43/64 | .6719 | 3 | 6 | 29/32 | .9062 | 3 | 6 | 1-5/16 | 1.3125 | 3 | 6 |
| 11/16 | .6875 | 3 | 6 | 59/64 | .9219 | 3 | 6 | 1-3/8 | 1.3750 | 3 | 6 |
| 45/64 | .7031 | 3 | 6 | 15/16 | .9375 | 3 | 6 | 1-7/16 | 1.4375 | 3 | 6 |
| 23/32 | .7188 | 3 | 6 | 61/64 | .9531 | 3 | 6 | 1-1/2 | 1.5000 | 3 | 6 |
| 47/64 | .7344 | 3 | 6 | 31/32 | .9688 | 3 | 6 | | | | |

DIN standard

ASME/ANSI standard

STRAIGHT SHANK

ASME-HSS DRILL BIT

EXTRA LONG



| D | D | L2 | L1 | D | D | L2 | L1 | D | D | L2 | L1 |
|------|-------|------|-------|------|------|------|-------|-----|-------|------|-------|
| 1/4 | 2500 | 9/13 | 12/18 | 7/16 | 4375 | 9/13 | 12/18 | 5/8 | .6250 | 9/13 | 12/18 |
| 5/16 | .3125 | 9/13 | 12/18 | 1/2 | 5000 | 9/13 | 12/18 | | | | |
| 3/8 | 3750 | 9/13 | 12/18 | 9/16 | 5625 | 9/13 | 12/18 | | | | |

HSS TWIST DRILL SET

ECH2901



29PCS TWIST DRILL SET
Size(inch):1/16-1/2 x 1/64

ECH2902



29PCS TWIST DRILL SET
Size(inch):1/16-1/2 x 1/64

ECH2101



21PCS TWIST DRILL SET
Size(inch):1/16-3/8 x 1/64inch

ECH2102



21PCS TWIST DRILL SET
Size(inch):1/16-3/8 x 1/64

ECH2103



21PCS TWIST DRILL SET
Size(inch):1/16-3/8 x 1/64

ECH2104



21PCS TWIST DRILL SET
Size(inch):1/16-3/8 x 1/64

ECH2105



21PCS TWIST DRILL SET
Size(inch):1/16-3/8 x 1/64

ECH2106



21PCS TWIST DRILL SET
Size(inch):1/16-3/8 x 1/64

ECH2903

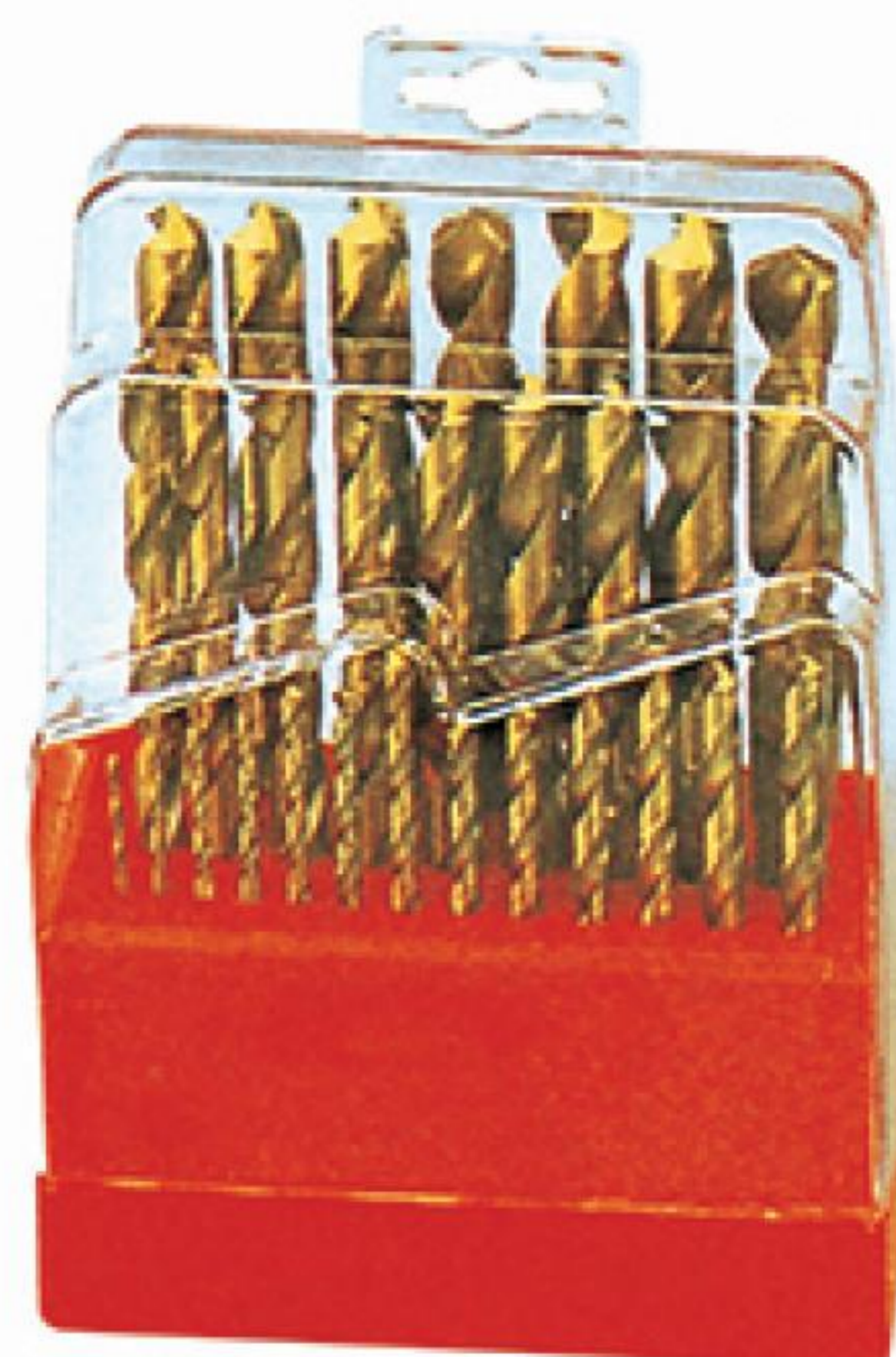

29PCS TWIST DRILL SET
Size(inch):1/16-1/2 x 1/64

SDS PLUS FLAT TIP DRILL BIT

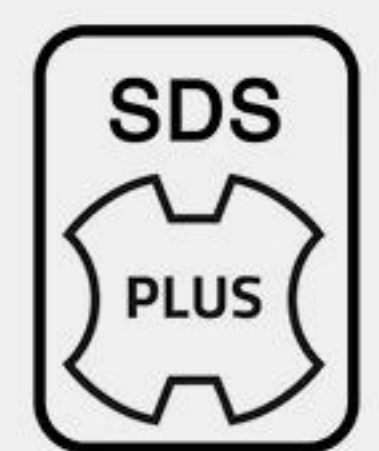

| Dia | Ovrall length | Dia | Ovrall length | Dia | Ovrall length | Dia | Ovrall length | Dia | Ovrall length |
|-------|---------------|------|---------------|------|---------------|------|---------------|------|---------------|
| 4mm | 110 | 8mm | 260 | 14mm | 500 | 22mm | 210 | 26mm | 800 |
| 4mm | 160 | 8mm | 310 | 14mm | 600 | 22mm | 260 | 26mm | 1000 |
| 4mm | 210 | 8mm | 350 | 14mm | 800 | 22mm | 310 | 28mm | 210 |
| 5mm | 110 | 8mm | 400 | 14mm | 1000 | 22mm | 350 | 28mm | 260 |
| 5mm | 160 | 8mm | 450 | 16mm | 160 | 22mm | 400 | 28mm | 310 |
| 5mm | 210 | 8mm | 500 | 16mm | 210 | 22mm | 450 | 28mm | 350 |
| 5mm | 260 | 8mm | 600 | 16mm | 260 | 22mm | 500 | 28mm | 400 |
| 5.5mm | 110 | 10mm | 110 | 16mm | 310 | 22mm | 600 | 28mm | 450 |
| 5.5mm | 160 | 10mm | 160 | 16mm | 350 | 22mm | 800 | 28mm | 500 |
| 5.5mm | 210 | 10mm | 210 | 16mm | 400 | 22mm | 1000 | 28mm | 600 |
| 5.5mm | 260 | 10mm | 260 | 16mm | 450 | 24mm | 210 | 28mm | 800 |
| 6mm | 110 | 10mm | 310 | 16mm | 500 | 24mm | 260 | 28mm | 1000 |
| 6mm | 160 | 10mm | 350 | 16mm | 600 | 24mm | 310 | 30mm | 210 |
| 6mm | 210 | 10mm | 400 | 16mm | 800 | 24mm | 350 | 30mm | 260 |
| 6mm | 260 | 10mm | 450 | 16mm | 1000 | 24mm | 400 | 30mm | 310 |
| 6mm | 310 | 10mm | 500 | 18mm | 160 | 24mm | 450 | 30mm | 350 |
| 6mm | 350 | 10mm | 600 | 18mm | 210 | 24mm | 500 | 30mm | 400 |
| 6mm | 400 | 10mm | 800 | 18mm | 260 | 24mm | 600 | 30mm | 450 |
| 6mm | 450 | 10mm | 1000 | 18mm | 310 | 24mm | 800 | 30mm | 500 |
| 6.5mm | 110 | 12mm | 110 | 18mm | 350 | 24mm | 1000 | 30mm | 600 |
| 6.5mm | 160 | 12mm | 160 | 18mm | 400 | 25mm | 210 | 30mm | 800 |
| 6.5mm | 210 | 12mm | 210 | 18mm | 450 | 25mm | 260 | 30mm | 1000 |
| 6.5mm | 260 | 12mm | 260 | 18mm | 500 | 25mm | 310 | 32mm | 210 |
| 6.5mm | 310 | 12mm | 310 | 18mm | 600 | 25mm | 350 | 32mm | 260 |
| 6.5mm | 350 | 12mm | 350 | 18mm | 800 | 25mm | 400 | 32mm | 310 |
| 6.5mm | 400 | 12mm | 400 | 18mm | 1000 | 25mm | 450 | 32mm | 350 |
| 6.5mm | 450 | 12mm | 450 | 20mm | 160 | 25mm | 500 | 32mm | 400 |
| 7mm | 110 | 12mm | 500 | 20mm | 210 | 25mm | 600 | 32mm | 450 |
| 7mm | 160 | 12mm | 600 | 20mm | 260 | 25mm | 800 | 32mm | 500 |
| 7mm | 210 | 12mm | 800 | 20mm | 310 | 25mm | 1000 | 32mm | 600 |
| 7mm | 260 | 12mm | 1000 | 20mm | 350 | 26mm | 210 | 32mm | 800 |
| 7mm | 310 | 14mm | 160 | 20mm | 400 | 26mm | 260 | 32mm | 1000 |
| 7mm | 350 | 14mm | 210 | 20mm | 450 | 26mm | 310 | | |
| 7mm | 400 | 14mm | 260 | 20mm | 500 | 26mm | 350 | | |
| 7mm | 450 | 14mm | 310 | 20mm | 600 | 26mm | 400 | | |
| 8mm | 110 | 14mm | 350 | 20mm | 800 | 26mm | 450 | | |
| 8mm | 160 | 14mm | 400 | 20mm | 1000 | 26mm | 500 | | |
| 8mm | 210 | 14mm | 450 | 22mm | 160 | 26mm | 600 | | |

SDS PLUS CROSS TIP DRILL BIT



| Dia | Ovrall length | Dia | Ovrall length | Dia | Ovrall length | Dia | Ovrall length | Dia | Ovrall length |
|-------|---------------|------|---------------|------|---------------|------|---------------|------|---------------|
| 5mm | 110 | 8mm | 500 | 14mm | 1000 | 22mm | 260 | 26mm | 600 |
| 5mm | 160 | 8mm | 600 | 16mm | 160 | 22mm | 310 | 26mm | 800 |
| 5mm | 210 | 10mm | 110 | 16mm | 210 | 22mm | 350 | 26mm | 1000 |
| 5mm | 260 | 10mm | 160 | 16mm | 260 | 22mm | 400 | 28mm | 210 |
| 6mm | 110 | 10mm | 210 | 16mm | 310 | 22mm | 450 | 28mm | 260 |
| 6mm | 160 | 10mm | 260 | 16mm | 350 | 22mm | 500 | 28mm | 310 |
| 6mm | 210 | 10mm | 310 | 16mm | 400 | 22mm | 600 | 28mm | 350 |
| 6mm | 260 | 10mm | 350 | 16mm | 450 | 22mm | 800 | 28mm | 400 |
| 6mm | 310 | 10mm | 400 | 16mm | 500 | 22mm | 1000 | 28mm | 450 |
| 6mm | 350 | 10mm | 450 | 16mm | 600 | 24mm | 210 | 28mm | 500 |
| 6mm | 400 | 10mm | 500 | 16mm | 800 | 24mm | 260 | 28mm | 600 |
| 6mm | 450 | 10mm | 600 | 16mm | 1000 | 24mm | 310 | 28mm | 800 |
| 6.5mm | 110 | 10mm | 800 | 18mm | 160 | 24mm | 350 | 28mm | 1000 |
| 6.5mm | 160 | 10mm | 1000 | 18mm | 210 | 24mm | 400 | 30mm | 210 |
| 6.5mm | 210 | 12mm | 110 | 18mm | 260 | 24mm | 450 | 30mm | 260 |
| 6.5mm | 260 | 12mm | 160 | 18mm | 310 | 24mm | 500 | 30mm | 310 |
| 6.5mm | 310 | 12mm | 210 | 18mm | 350 | 24mm | 600 | 30mm | 350 |
| 6.5mm | 350 | 12mm | 260 | 18mm | 400 | 24mm | 800 | 30mm | 400 |
| 6.5mm | 400 | 12mm | 310 | 18mm | 450 | 24mm | 1000 | 30mm | 450 |
| 6.5mm | 450 | 12mm | 350 | 18mm | 500 | 25mm | 210 | 30mm | 500 |
| 7mm | 110 | 12mm | 400 | 18mm | 600 | 25mm | 260 | 30mm | 600 |
| 7mm | 160 | 12mm | 450 | 18mm | 800 | 25mm | 310 | 30mm | 800 |
| 7mm | 210 | 12mm | 500 | 18mm | 1000 | 25mm | 350 | 30mm | 1000 |
| 7mm | 260 | 12mm | 600 | 20mm | 160 | 25mm | 400 | 32mm | 260 |
| 7mm | 310 | 12mm | 800 | 20mm | 210 | 25mm | 450 | 32mm | 310 |
| 7mm | 350 | 12mm | 1000 | 20mm | 260 | 25mm | 500 | 32mm | 350 |
| 7mm | 400 | 14mm | 160 | 20mm | 310 | 25mm | 600 | 32mm | 400 |
| 7mm | 450 | 14mm | 210 | 20mm | 350 | 25mm | 800 | 32mm | 450 |
| 8mm | 110 | 14mm | 260 | 20mm | 400 | 25mm | 1000 | 32mm | 500 |
| 8mm | 160 | 14mm | 310 | 20mm | 450 | 26mm | 210 | 32mm | 600 |
| 8mm | 210 | 14mm | 350 | 20mm | 500 | 26mm | 260 | 32mm | 800 |
| 8mm | 260 | 14mm | 400 | 20mm | 600 | 26mm | 310 | 32mm | 1000 |
| 8mm | 310 | 14mm | 450 | 20mm | 800 | 26mm | 350 | | |
| 8mm | 350 | 14mm | 500 | 20mm | 1000 | 26mm | 400 | | |
| 8mm | 400 | 14mm | 600 | 22mm | 160 | 26mm | 450 | | |
| 8mm | 450 | 14mm | 800 | 22mm | 210 | 26mm | 500 | | |

SDS PLUS TRIANGLE TIP DRILL BIT



| Dia | | Ovrall length | | Dia | | Ovrall length | |
|------|-----|---------------|-----|-----|--|---------------|--|
| 5mm | 110 | 14mm | 310 | | | | |
| 5mm | 160 | 14mm | 350 | | | | |
| 6mm | 110 | 14mm | 450 | | | | |
| 6mm | 160 | 14mm | 600 | | | | |
| 6mm | 210 | 16mm | 160 | | | | |
| 6mm | 260 | 16mm | 210 | | | | |
| 6mm | 310 | 16mm | 260 | | | | |
| 8mm | 110 | 16mm | 310 | | | | |
| 8mm | 160 | 16mm | 350 | | | | |
| 8mm | 210 | 16mm | 450 | | | | |
| 8mm | 260 | 16mm | 600 | | | | |
| 8mm | 310 | 18mm | 210 | | | | |
| 8mm | 350 | 18mm | 260 | | | | |
| 8mm | 460 | 18mm | 350 | | | | |
| 10mm | 110 | 18mm | 450 | | | | |
| 10mm | 160 | 18mm | 600 | | | | |
| 10mm | 210 | 20mm | 210 | | | | |
| 10mm | 260 | 20mm | 250 | | | | |
| 10mm | 310 | 20mm | 350 | | | | |
| 10mm | 350 | 20mm | 450 | | | | |
| 10mm | 450 | 20mm | 600 | | | | |
| 10mm | 600 | 22mm | 210 | | | | |
| 12mm | 160 | 22mm | 250 | | | | |
| 12mm | 210 | 22mm | 350 | | | | |
| 12mm | 260 | 22mm | 450 | | | | |
| 12mm | 310 | 22mm | 600 | | | | |
| 12mm | 350 | 25mm | 210 | | | | |
| 12mm | 450 | 25mm | 250 | | | | |
| 12mm | 600 | 25mm | 350 | | | | |
| 14mm | 160 | 25mm | 450 | | | | |
| 14mm | 210 | 25mm | 600 | | | | |
| 14mm | 260 | | | | | | |

SDS PLUS SOLID CARBIDE CROSS TIP DRILL BIT



| Dia | Ovrall length |
|-------|---------------|
| 4mm | 110 |
| 4mm | 160 |
| 5.5mm | 110 |
| 5.5mm | 160 |
| 5mm | 110 |
| 5mm | 160 |
| 5mm | 210 |
| 6mm | 110 |
| 6mm | 160 |
| 6mm | 210 |
| 6mm | 260 |
| 6mm | 310 |
| 6.5mm | 110 |
| 6.5mm | 160 |
| 6.5mm | 210 |
| 6.5mm | 260 |
| 6.5mm | 310 |
| 7mm | 110 |
| 7mm | 160 |
| 7mm | 210 |
| 7mm | 260 |
| 7mm | 310 |
| 8mm | 110 |
| 8mm | 160 |
| 8mm | 210 |
| 8mm | 260 |
| 8mm | 310 |
| 8mm | 360 |
| 8mm | 410 |
| 8mm | 460 |
| 9.8mm | 110 |
| 9.8mm | 160 |
| 9.8mm | 210 |
| 9.8mm | 260 |
| 9.8mm | 310 |

| Dia | Ovrall length |
|-------|---------------|
| 9.8mm | 360 |
| 9.8mm | 460 |
| 9.8mm | 600 |
| 10mm | 110 |
| 10mm | 160 |
| 10mm | 210 |
| 10mm | 260 |
| 10mm | 310 |
| 10mm | 360 |
| 10mm | 410 |
| 10mm | 460 |
| 10mm | 600 |
| 12mm | 160 |
| 12mm | 210 |
| 12mm | 260 |
| 12mm | 310 |
| 12mm | 360 |
| 12mm | 410 |
| 12mm | 460 |
| 12mm | 600 |
| 13mm | 160 |
| 13mm | 210 |
| 13mm | 260 |
| 13mm | 310 |
| 13mm | 360 |
| 13mm | 410 |
| 13mm | 600 |
| 14mm | 160 |
| 14mm | 210 |
| 14mm | 260 |
| 14mm | 310 |
| 14mm | 360 |
| 14mm | 410 |
| 14mm | 600 |

SDS MAX DRILL BIT



| Dia | Ovrrall length | Dia | Ovrrall length | Dia | Ovrrall length | Dia | Ovrrall length | Dia | Ovrrall length |
|------|----------------|------|----------------|------|----------------|------|----------------|------|----------------|
| 8mm | 280 | 16mm | 1000 | 25mm | 280 | 30mm | 340 | 38mm | 505 |
| 10mm | 280 | 18mm | 280 | 25mm | 320 | 30mm | 370 | 38mm | 520 |
| 10mm | 320 | 18mm | 320 | 25mm | 340 | 30mm | 400 | 38mm | 570 |
| 10mm | 340 | 18mm | 340 | 25mm | 370 | 30mm | 420 | 38mm | 600 |
| 10mm | 370 | 18mm | 370 | 25mm | 400 | 30mm | 505 | 38mm | 800 |
| 10mm | 400 | 18mm | 400 | 25mm | 420 | 30mm | 520 | 38mm | 1000 |
| 10mm | 420 | 18mm | 420 | 25mm | 505 | 30mm | 570 | 40mm | 340 |
| 12mm | 280 | 18mm | 505 | 25mm | 520 | 30mm | 600 | 40mm | 370 |
| 12mm | 320 | 18mm | 520 | 25mm | 570 | 30mm | 800 | 40mm | 400 |
| 12mm | 340 | 18mm | 570 | 25mm | 600 | 30mm | 1000 | 40mm | 420 |
| 12mm | 370 | 18mm | 600 | 25mm | 800 | 32mm | 320 | 40mm | 505 |
| 12mm | 400 | 18mm | 800 | 25mm | 1000 | 32mm | 340 | 40mm | 520 |
| 12mm | 420 | 18mm | 1000 | 26mm | 280 | 32mm | 370 | 40mm | 570 |
| 12mm | 505 | 20mm | 280 | 26mm | 320 | 32mm | 400 | 40mm | 600 |
| 12mm | 520 | 20mm | 320 | 26mm | 340 | 32mm | 420 | 40mm | 800 |
| 12mm | 570 | 20mm | 340 | 26mm | 370 | 32mm | 505 | 40mm | 1000 |
| 14mm | 280 | 20mm | 370 | 26mm | 400 | 32mm | 520 | 45mm | 505 |
| 14mm | 320 | 20mm | 400 | 26mm | 420 | 32mm | 570 | 45mm | 800 |
| 14mm | 340 | 20mm | 420 | 26mm | 505 | 32mm | 600 | 50mm | 505 |
| 14mm | 370 | 20mm | 505 | 26mm | 520 | 32mm | 800 | 50mm | 800 |
| 14mm | 400 | 20mm | 520 | 26mm | 570 | 32mm | 1000 | | |
| 14mm | 420 | 20mm | 570 | 26mm | 600 | 35mm | 320 | | |
| 14mm | 505 | 20mm | 600 | 26mm | 800 | 35mm | 340 | | |
| 14mm | 520 | 20mm | 800 | 26mm | 1000 | 35mm | 370 | | |
| 14mm | 570 | 20mm | 1000 | 28mm | 280 | 35mm | 400 | | |
| 14mm | 600 | 22mm | 280 | 28mm | 320 | 35mm | 400 | | |
| 16mm | 280 | 22mm | 320 | 28mm | 340 | 35mm | 505 | | |
| 16mm | 320 | 22mm | 340 | 28mm | 370 | 35mm | 520 | | |
| 16mm | 340 | 22mm | 370 | 28mm | 400 | 35mm | 570 | | |
| 16mm | 370 | 22mm | 400 | 28mm | 420 | 35mm | 600 | | |
| 16mm | 400 | 22mm | 420 | 28mm | 505 | 35mm | 800 | | |
| 16mm | 420 | 22mm | 505 | 28mm | 520 | 35mm | 1000 | | |
| 16mm | 505 | 22mm | 520 | 28mm | 570 | 38mm | 320 | | |
| 16mm | 520 | 22mm | 570 | 28mm | 600 | 38mm | 340 | | |
| 16mm | 570 | 22mm | 600 | 28mm | 800 | 38mm | 370 | | |
| 16mm | 600 | 22mm | 800 | 28mm | 1000 | 38mm | 400 | | |
| 16mm | 800 | 22mm | 1000 | 30mm | 320 | 38mm | 420 | | |

SDS DRILL BIT PACKING



TRANSPARENT PLASTIC TUBE



PLASTIC TUBE



PLASTIC TUBE



PVC BAG



HALF SKIN CARD



SMALL HANGER



SMALL HANGER



BIG HANGER



BLISTER CARD

*Other color hangers are available

DRILL SET

● **3PCS SDS DRILL SET**

12/16/24X600(MM)

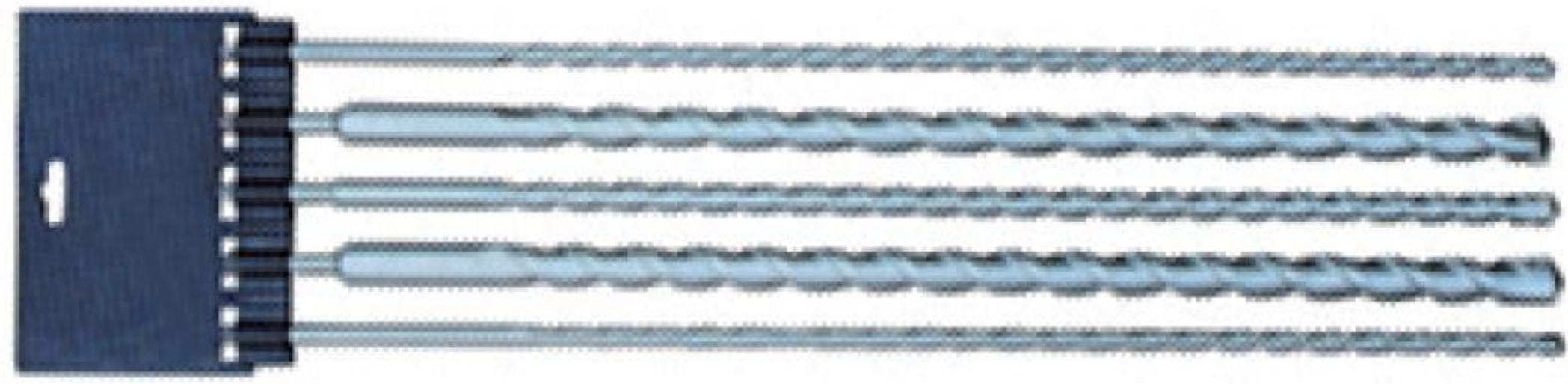

● **3PCS SDS DRILL SET**

12/16/24X1000(MM)

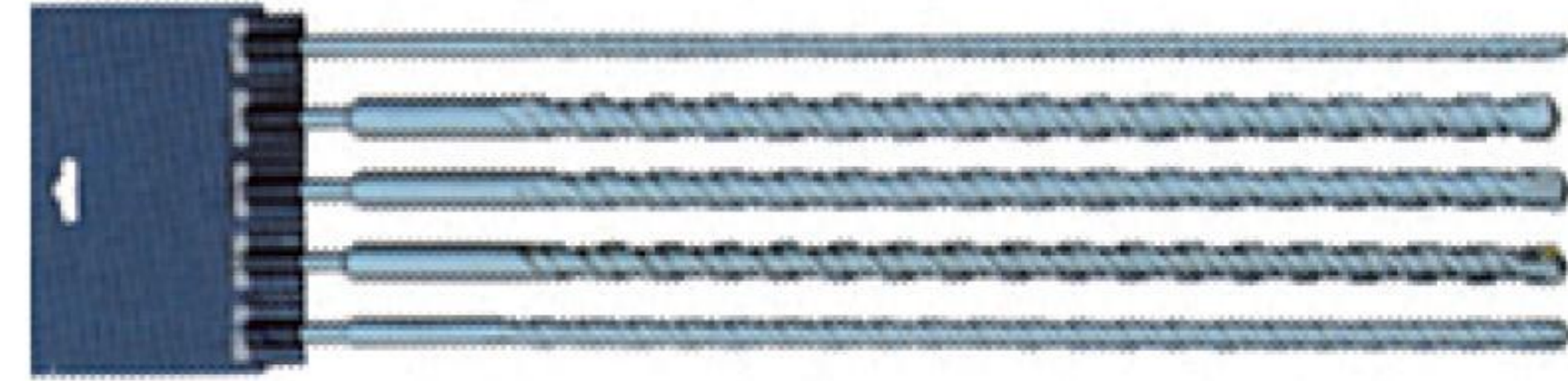

● **5PCS SDS DRILL SET**

12/14/16/18/22X450(MM)

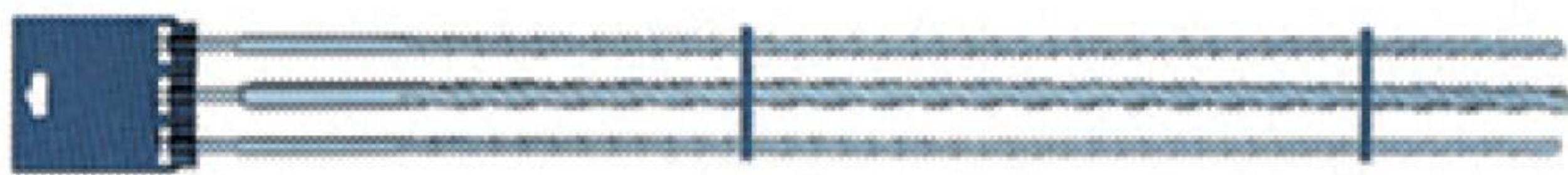

● **5PCS SDS DRILL SET**

12/14/16/22/24X600(MM)



● **5PCS SDS DRILL SET**

5/6/8/10/12X160(MM)



● **3PCS SDS DRILL SET**

5/6X110(MM) 8X160(MM)
5X110(MM) 6/8X160(MM)

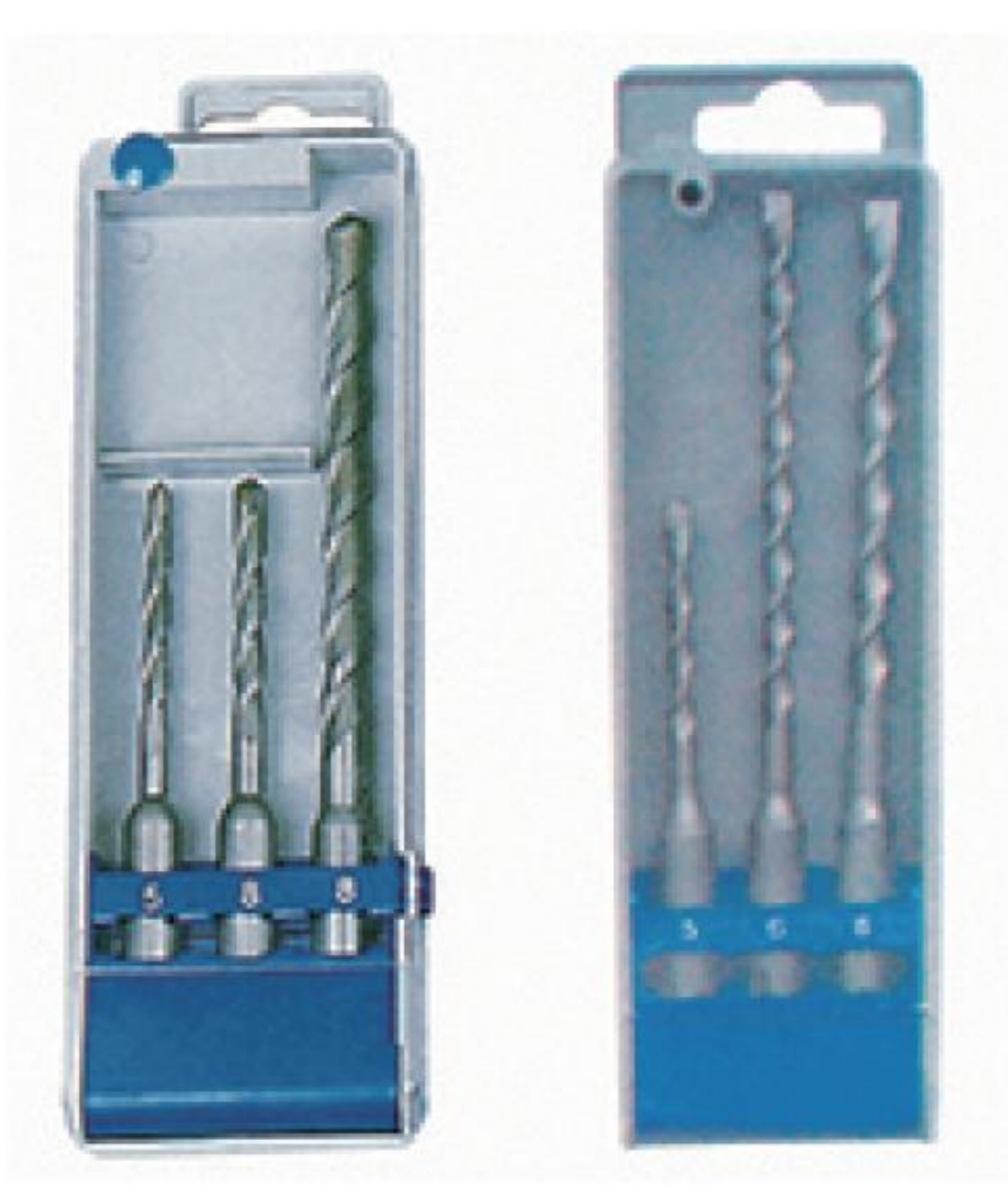

● **4PCS SDS DRILL SET**

5/6/8/10X160(MM)



● **5PCS SDS DRILL SET**

5/6/8/10/12X160(MM)
5/6/8X110(MM) 10/12X160(MM)



● **6PCS SDS DRILL SET**

10/12/14/16/18/20X450(MM)

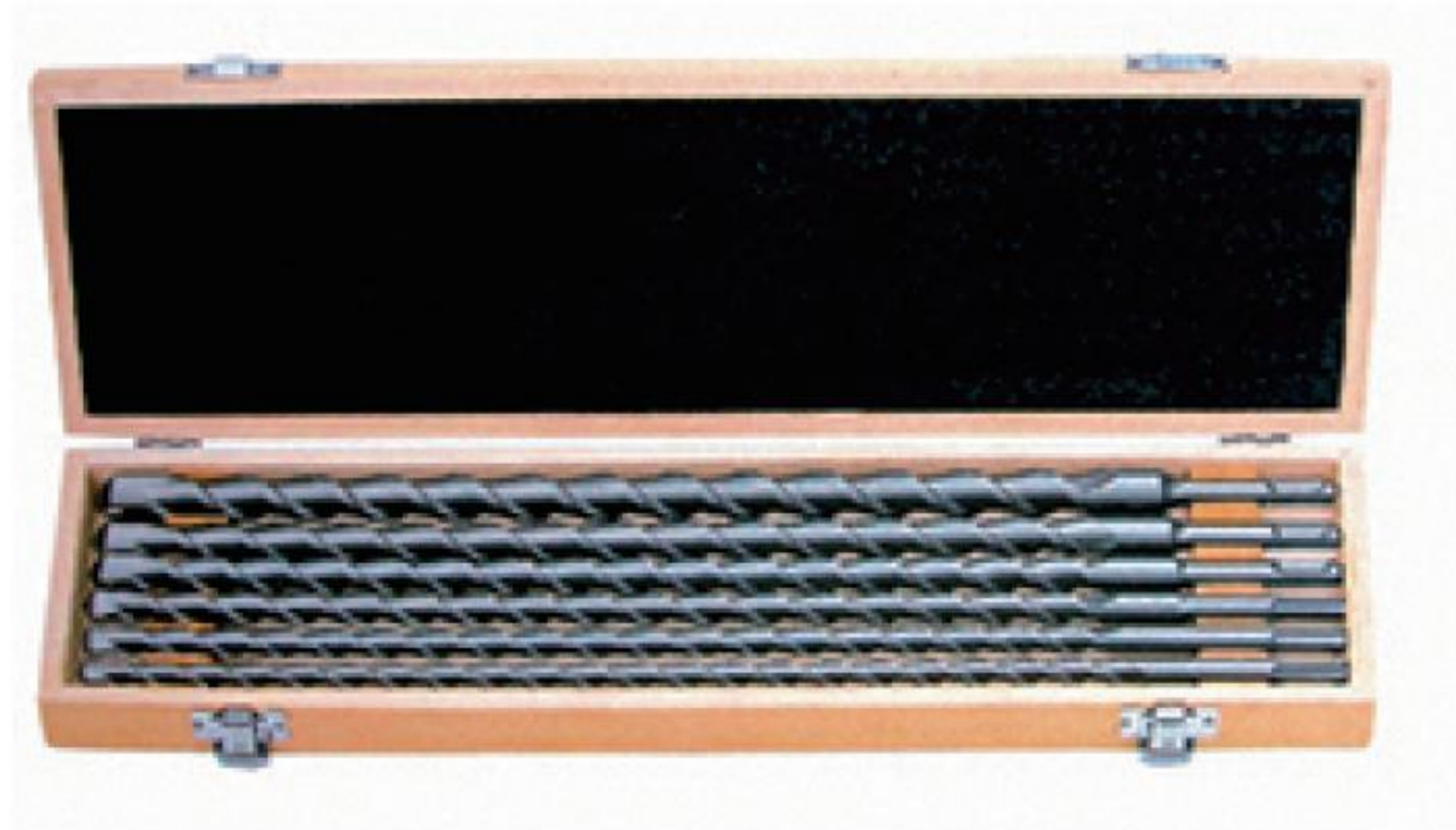

● **6PCS SDS DRILL SET**

6/8/10X110(MM) 6/8/10X160(MM)



● **6PCS SDS DRILL SET**

16/8/10X110(MM) 6/8/10X160(MM)



● **7PCS SDS DRILL SET**

5/6/8X110(MM) 6/8/10/12X160(MM)

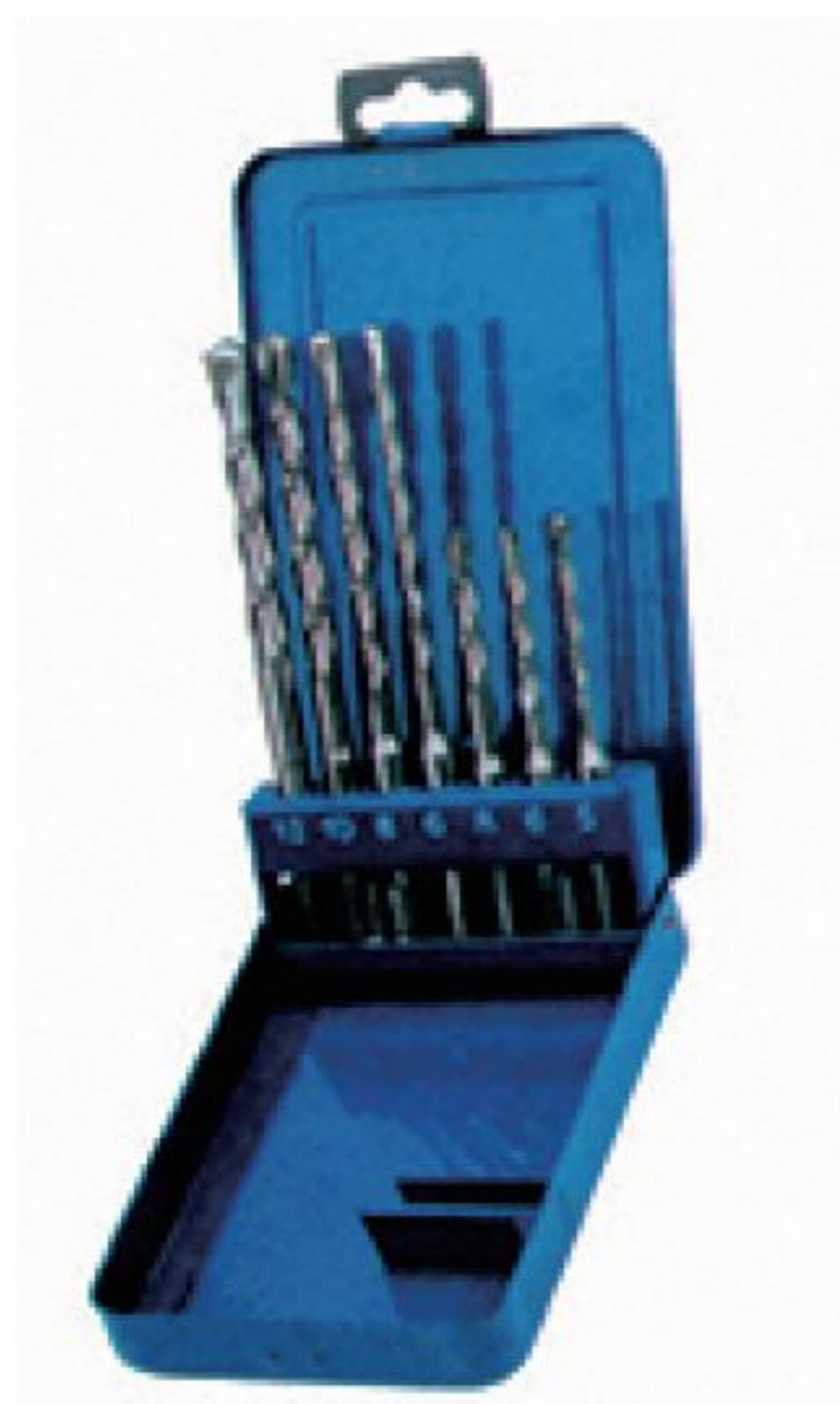

5/6/8X110(MM) 6/8/10/12X160(MM)



● **8PCS SDS DRILL SET**

5/6/8/10X110(MM) 5/6/8/10X160(MM)

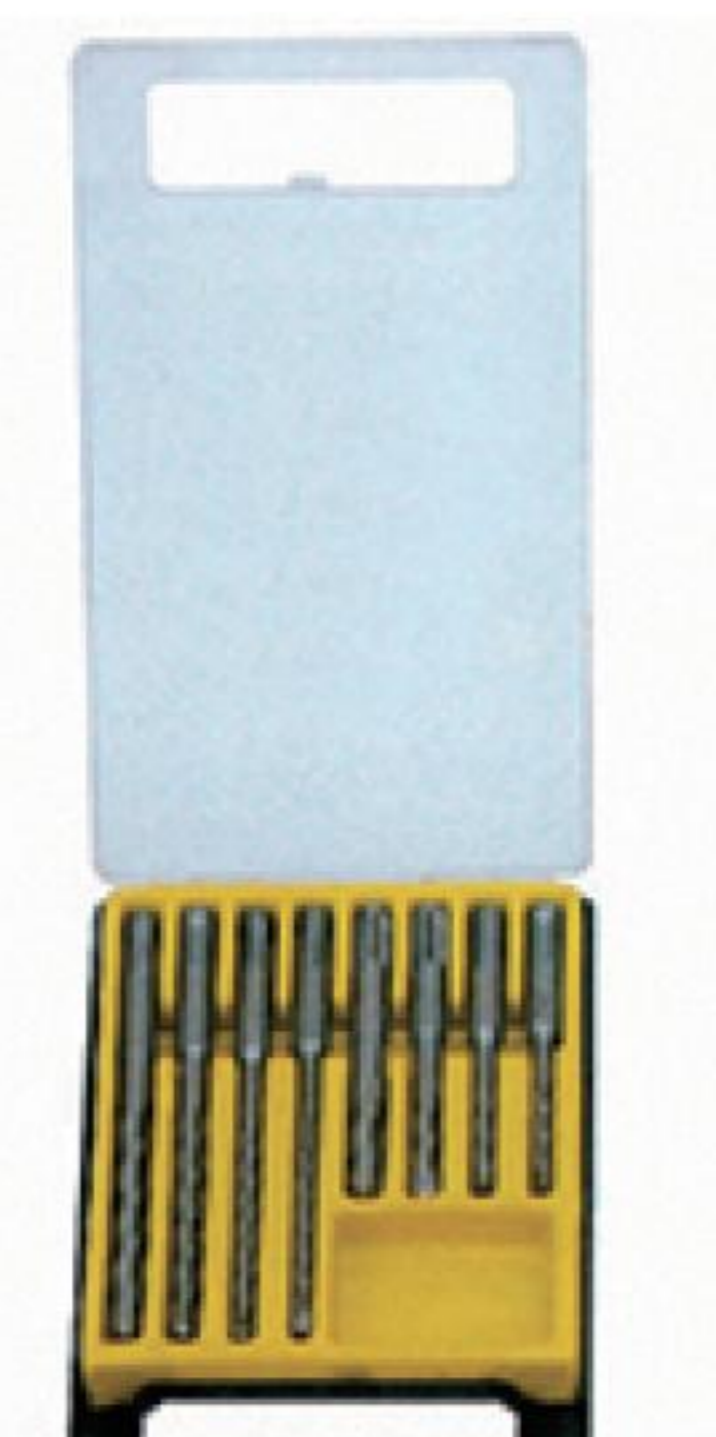

DRILL SET

● 11PCS SDS DRILL SET

5/6X110(MM) 6/8/10X150(MM) 10/12X210(MM) 10/12/16/20X450(MM)

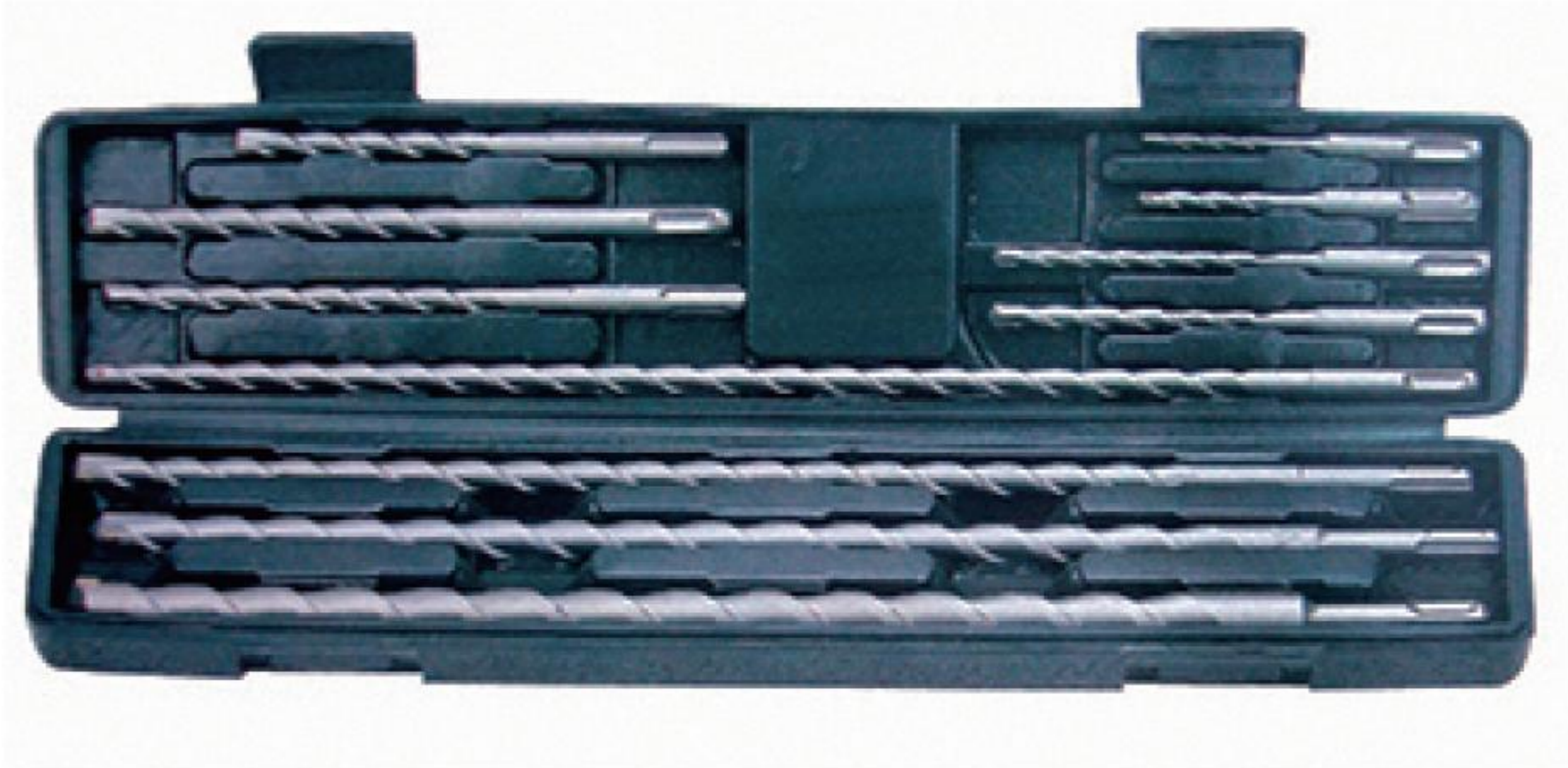

● 11PCS SDS DRILL SET

5/6X110(MM) 6/8/10X150(MM) 10/12X210(MM) 10/12/16/20X450(MM)

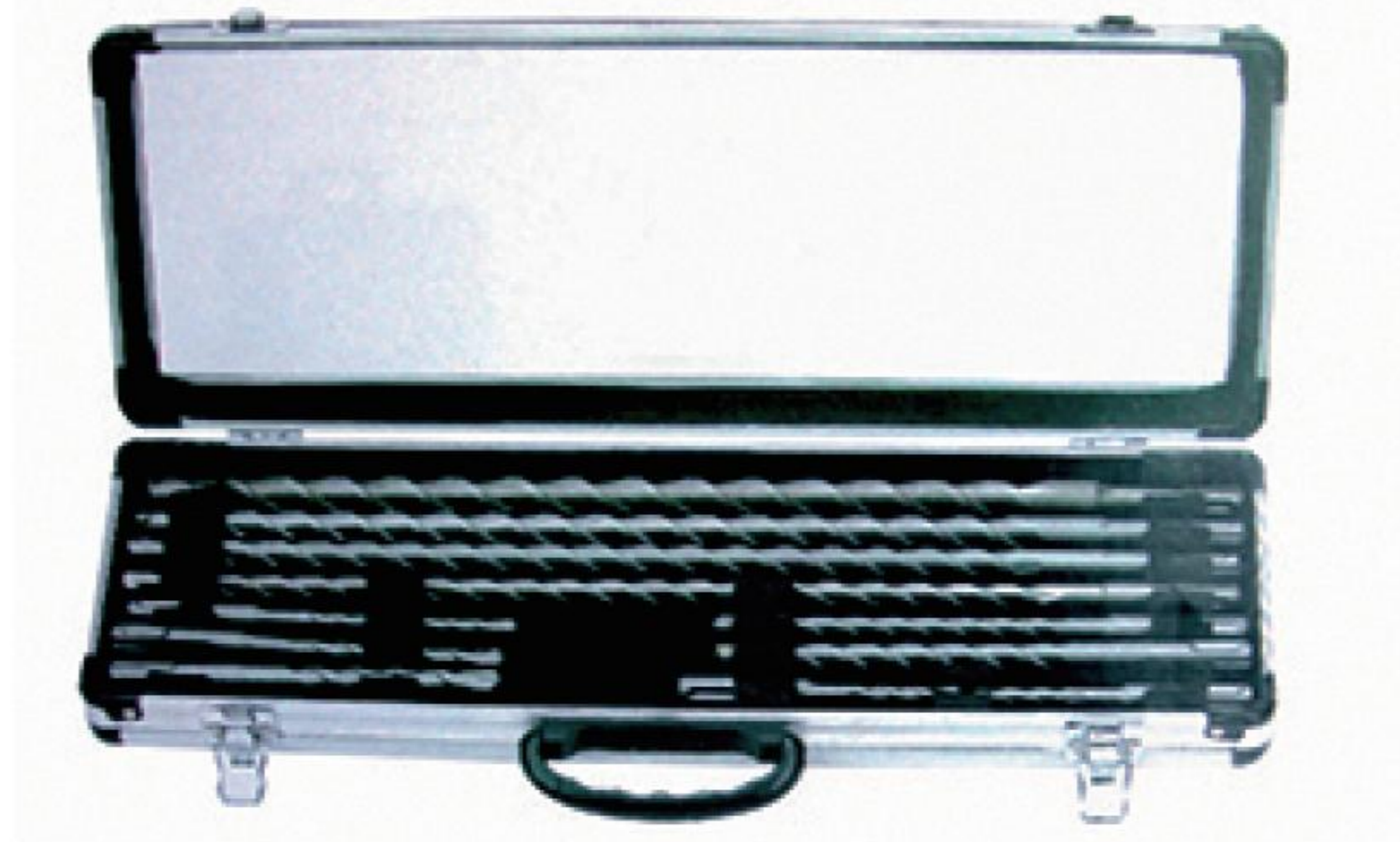

● 20PCS SDS DRILL SET

5/6/8X110(MM) 6/8/8/10/10/12X160(MM) 8/10/12/14X210(MM)
14/16X260(MM) 10/12/16/20X450(MM)

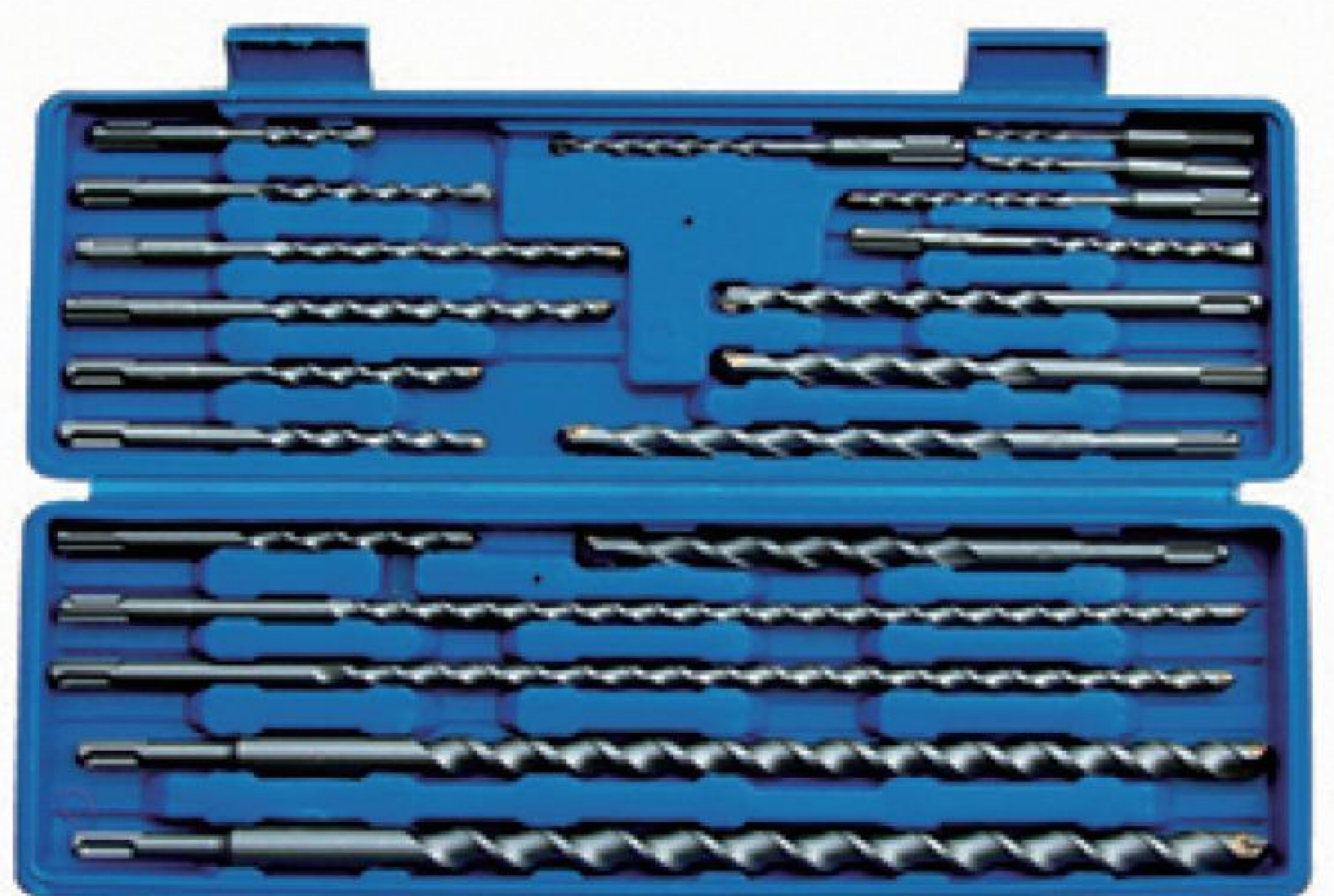

● 50PCS SDS DRILL SET

5X110(MM)X10PCS
6X110(MM)X10PCS
6X160(MM)X5PCS
8X160(MM)X5PCS
10X160(MM)X5PCS
8X210(MM)X5PCS
10X210(MM)X5PCS
12X210(MM)X5PCS



● 10PCS SDS DRILL SET

5/6/8X110(MM) 10/12X160(MM) 14/16X210(MM) 20X400(MM)
POINT CHISEL:14X250MM
FLAT CHISEL:14X250X40MM



● 12PCS SDS DRILL SET

5/6X110(MM) 8/10/12X160(MM) 14X200(MM)
16X210(MM) 18X300(MM) 20X450 (MM)
POINT CHISEL:14X250(MM)
FLAT CHISEL:14X250X20(MM)
GROOVE CHISEL:14X250(MM)

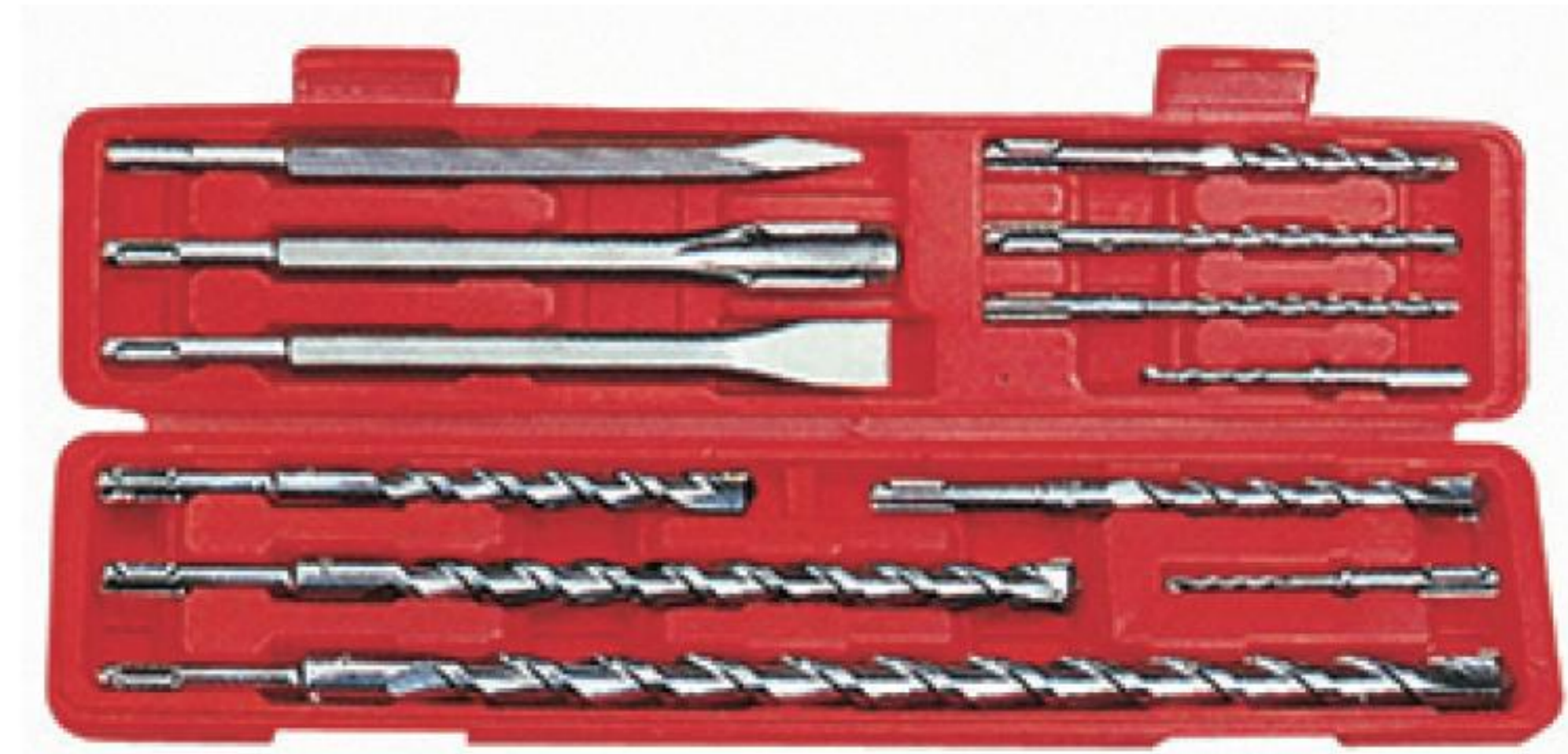

● 12PCS SDS DRILL SET

5/6X110(MM) 6/8/10X160(MM) 10/12X210(MM) 10/12/16X450(MM)
POINT CHISEL:14X250(MM) FLAT CHISEL:14X250X20(MM)



● 13PCS SDS DRILL SET

6/8/10X160(MM)
8/10/12X210(MM)
10/12/14X260(MM)
POINT CHISEL:14X250(MM)
FLAT CHISEL:14X250X20(MM)
14X250X40(MM)
GROOVE CHISEL:14X250(MM)



SDS CHISEL

EC001



SIZE:14*250mm 17*250mm

EC002



SIZE:14*250*20mm 17*250*22mm

EC003



SIZE:14*250*40mm

EC004



SIZE:18*300mm 18*400mm 18*600mm

EC005



SIZE:18*300*25mm 18*400*25mm 18*600*25mm

EC006



SIZE:18*300*50mm 18*400*50mm 18*600*50mm

EC007



SIZE:18*300mm 18*400mm 18*600mm

EC008



SIZE:18*300*50mm 18*400*50mm

EC017



SIZE:19*400mm

EC018



SIZE:19*330mm 19*400mm 19*500mm 22*45mm
25*500mm 28*550mm 32*550mm

EC019



SIZE:17*280mm

EC009



SIZE:17*280mm 17*450mm 21*320mm 21*450mm

EC010



SIZE:17*280*22mm 17*450*22mm 21*320*26mm 21*450*26mm

EC011



SIZE:17*280*50mm 17*450*50mm
21*320*50mm 21*450*50mm 17*280*75mm

EC012

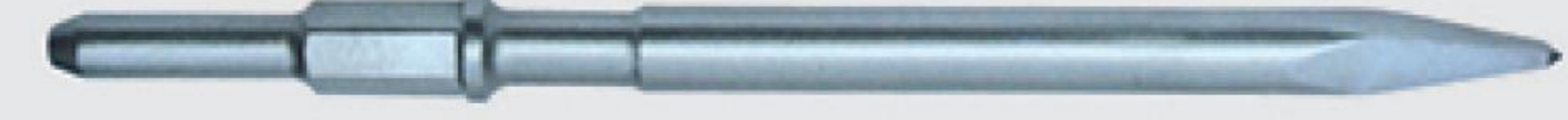

SIZE:17*280mm

EC013



SIZE:19*300mm 19*400mm 19*600mm

EC014



SIZE:19*300*25mm 19*400*25mm

EC015



SIZE:21*320mm 21*450mm

EC016



SIZE:21*320*26mm 21*450*26mm

EC024



SIZE:28*400*35mm 28*500*35mm

EC025



SIZE:22*380mm

EC026



SIZE:23.9*350mm

EC020



EC021 18mm



SIZE:18*270*22mm

EC022



SIZE:30*410mm

EC023



SIZE:30*410*35mm

EC027



EC028 28mm



SIZE:28*450mm

EC029



SIZE:19*300*80mm

EC030



SIZE:19*300*125mm



MASONRY DRILL/ CONCRETE DRILL BIT

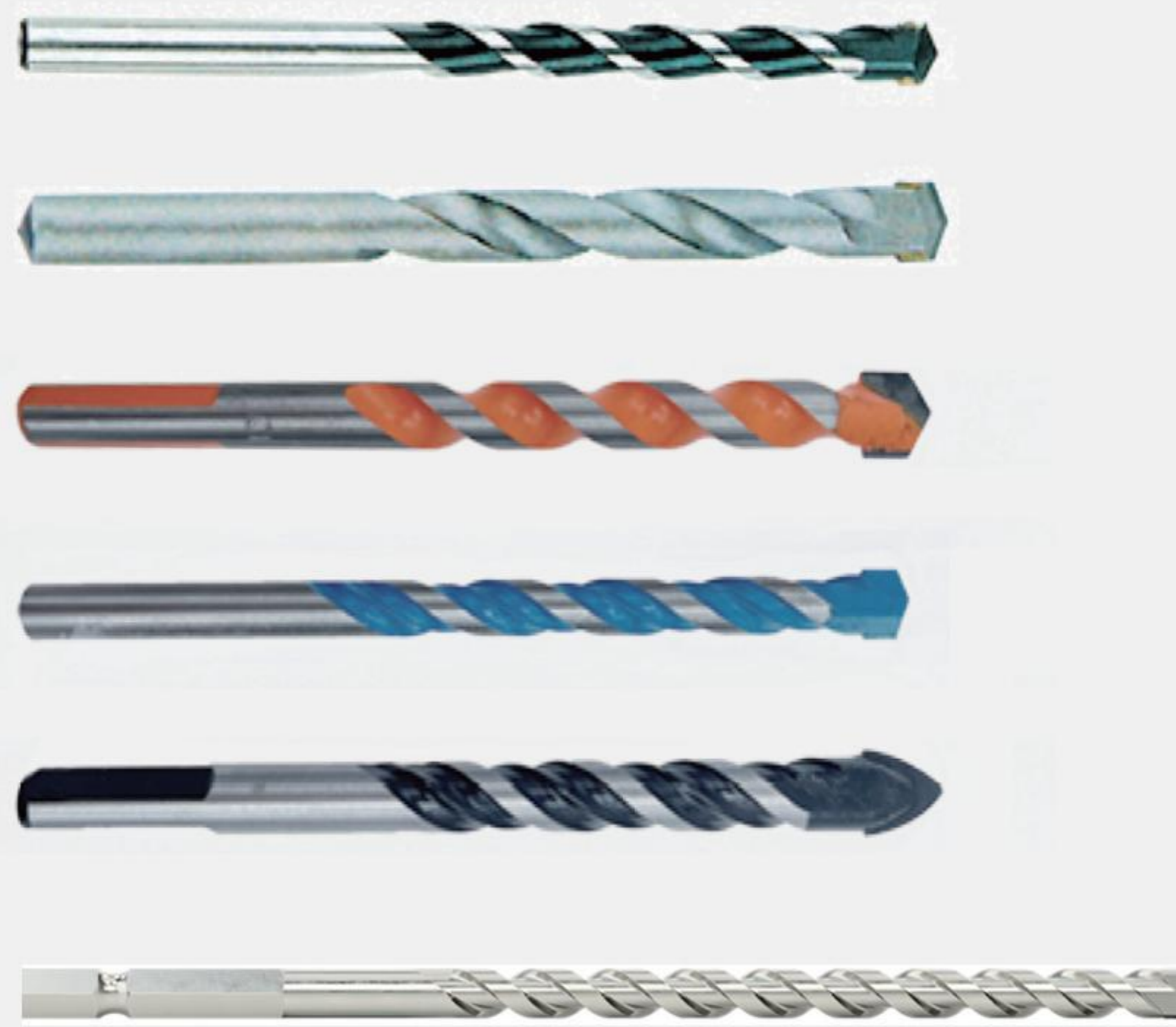

| Diameter | | Short Series | | Long Series | | Expanding Length (For drilling wall) | | | |
|-----------|------------------|--------------|---------|-------------|---------|--------------------------------------|---------|--------|---------|
| Size (mm) | +T14 +T12 (mm) | L (mm) | ≈l (mm) | L (mm) | ≈l (mm) | L (mm) | ≈l (mm) | L (mm) | ≈l (mm) |
| 3 | 0.35 | 60 | 35 | | | | | | |
| 4 | | 75 | 39 | | | | | | |
| 4.5 | | | | | | | | | |
| 5 | "+0.30 +0.12" | 85 | 39 | | | | | | |
| 5.5 | | | | 150 | 85 | | | | |
| 6 | | | | | | | | | |
| 6.5 | | 100 | 54 | | | | | | |
| 7 | | | | | | | | | |
| 8 | "+0.36 +0.15" | | | | | | | | |
| 8.5 | | 120 | 80 | | | | | | |
| 9 | | | | 200 | 135 | | | | |
| 10 | | | | | | | | | |
| 11 | | | | | | | | | |
| 12 | "+0.43 +0.18" | | | 220 | 150 | | | | |
| 13 | | 150 | 90 | | | | | | |
| 14 | | | | | | | | | |
| 16 | | | | | | | | | |
| 18 | | | | | | 400 | 350 | 600 | 550 |
| 20 | | | | | | | | | |
| 22 | "+0.52 +0.21" | 160 | 100 | | | | | | |
| 24 | | | | | | | | | |
| 25 | | | | | | | | | |

MASONRY DRILL SET / CONCRETE DRILL SET



AUGER BIT

● TYPE OF CUTTING BLADE



● TYPE OF SHANK

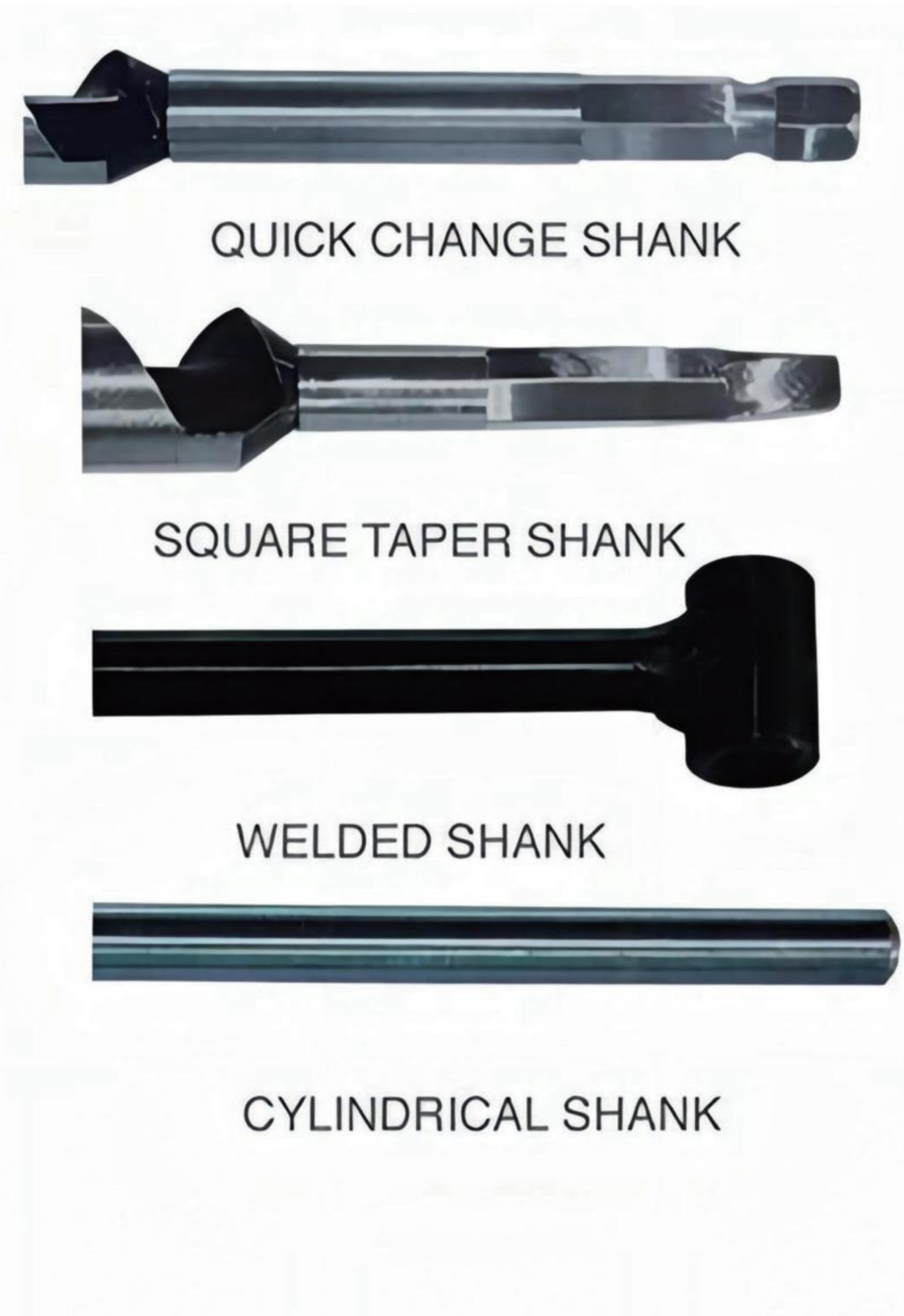

AUGER BIT

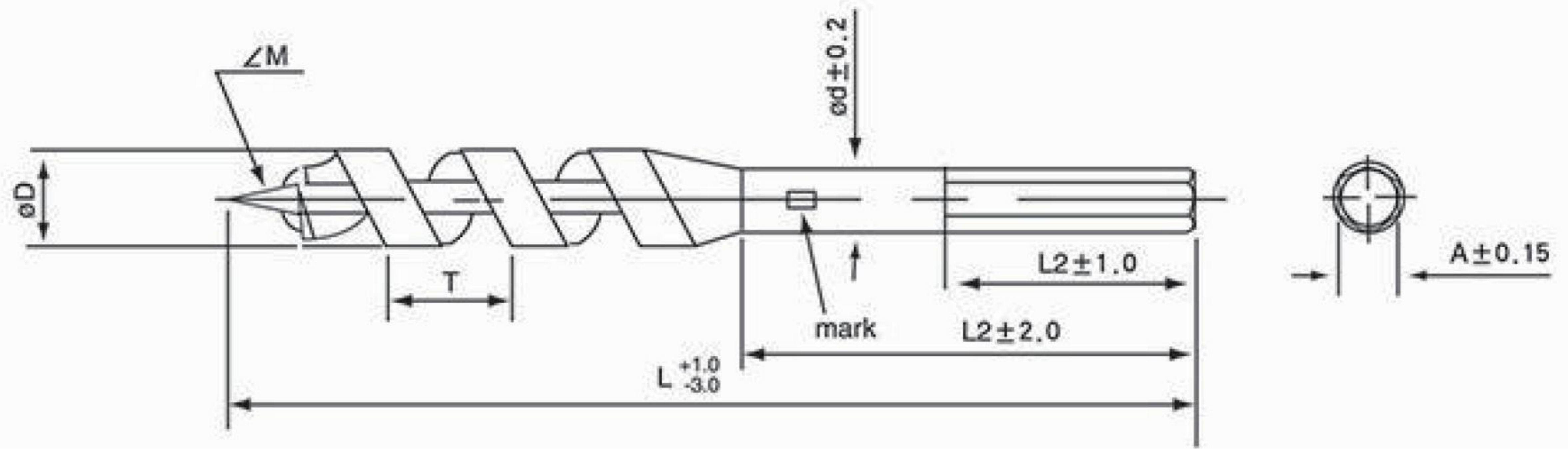

| DIA(mm) | D(mm) | L(mm) | Li(mm) | | L2(mm) | A(mm) | T(mm) | M(mm) | D(mm) |
|---------|-------|-------------------|-----------|--------|--------|-------|-------|-------|-------|
| 6 | | 75 100 | | | | 5.0 | 18 | 1.25 | 5.6 |
| 8 | | 50 200 | | | | 6.7 | 18 | 1.5 | 7.6 |
| 10 | | 300 400 460 | | | | 8.7 | 20 | 1.5 | 9.6 |
| 12 | | 500 600 | | | | 10.7 | 24 | 1.75 | 11.6 |
| 14 | | | | | | 11.20 | 28 | 1.75 | 12.5 |
| 16 | | | | | | 11.20 | 28 | 1.75 | 12.5 |
| 18 | | | L75 | L1=35 | L1=35 | 11.20 | 32 | 2.0 | 12.5 |
| 20 | | 100 | L100 | L1=40 | L2=25 | 11.20 | 32 | 2.0 | 12.5 |
| 22 | | 150 | L101-149 | L1=50 | L1<60 | 11.20 | 36 | 2.0 | 12.5 |
| 24 | | 200 | L150-200 | L1=60 | L2=28 | 11.20 | 36 | 2.0 | 12.5 |
| 26 | | 230 | L201-320 | L1=75 | L1>60 | 11.20 | 36 | 2.0 | 12.5 |
| 28 | | 300 | L330-400 | L1=80 | L2=232 | 11.20 | 40 | 2.5 | 12.5 |
| 30 | | 400 | L460-1500 | L1=100 | | 11.20 | 40 | 2.5 | 12.5 |
| 32 | | 460 | | | | 11.20 | 44 | 2.5 | 12.5 |
| 34 | | 500 | | | | 11.20 | 44 | 2.5 | 12.5 |
| 36 | | 600 | | | | 11.20 | 44 | 2.5 | 12.5 |
| 38 | | 900 | | | | 11.20 | 44 | 2.5 | 12.5 |
| 40 | | 1200 1500 | | | | 11.20 | 44 | 2.5 | 12.5 |

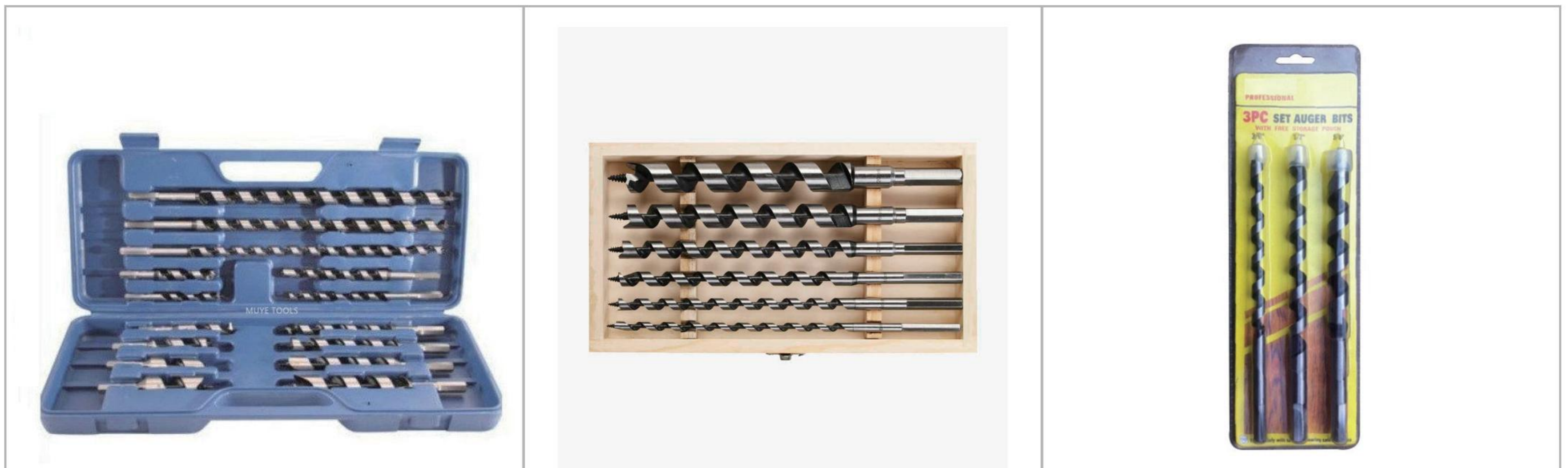

AUGER BIT SET

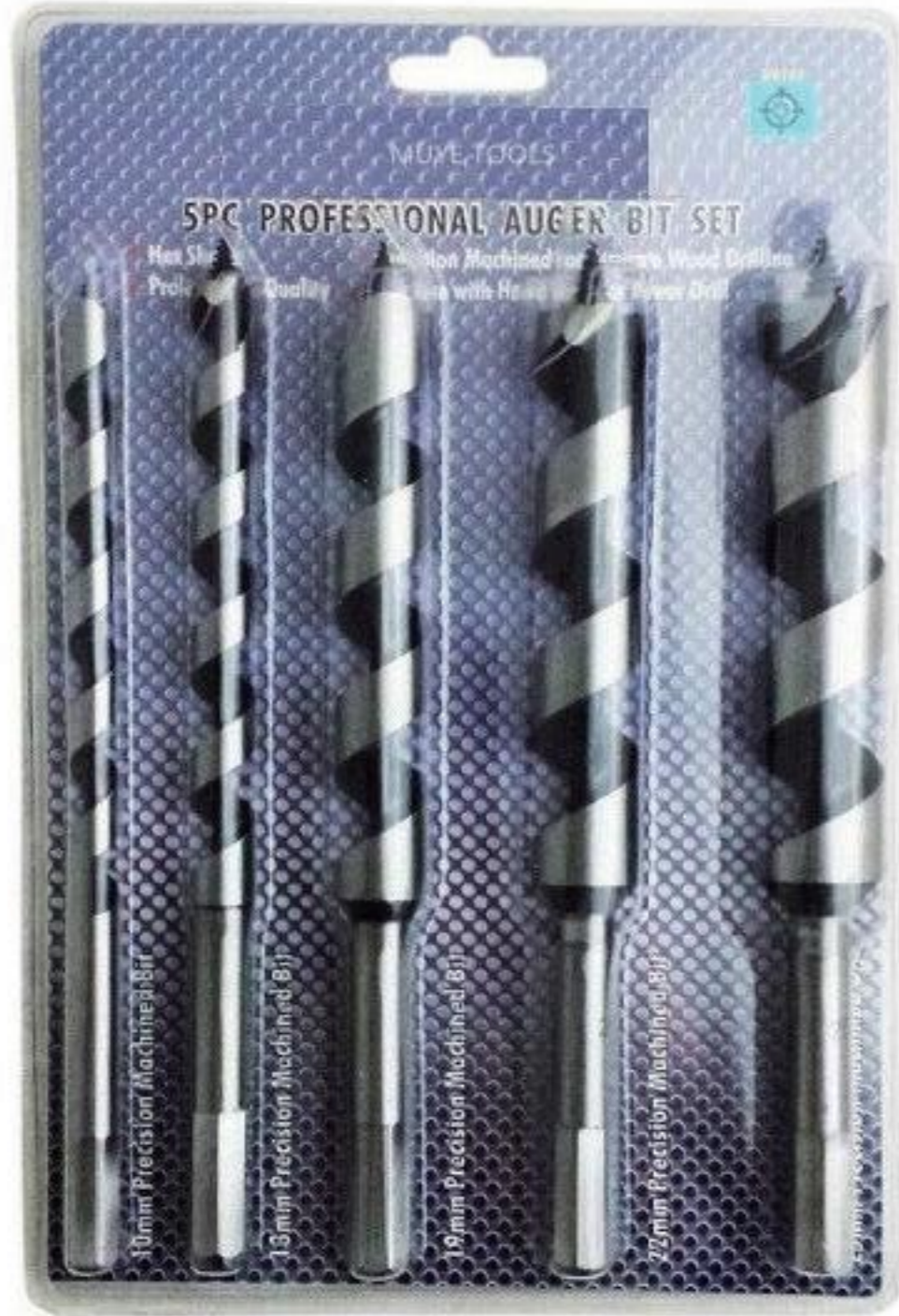

BRAD POINT DRILL BIT

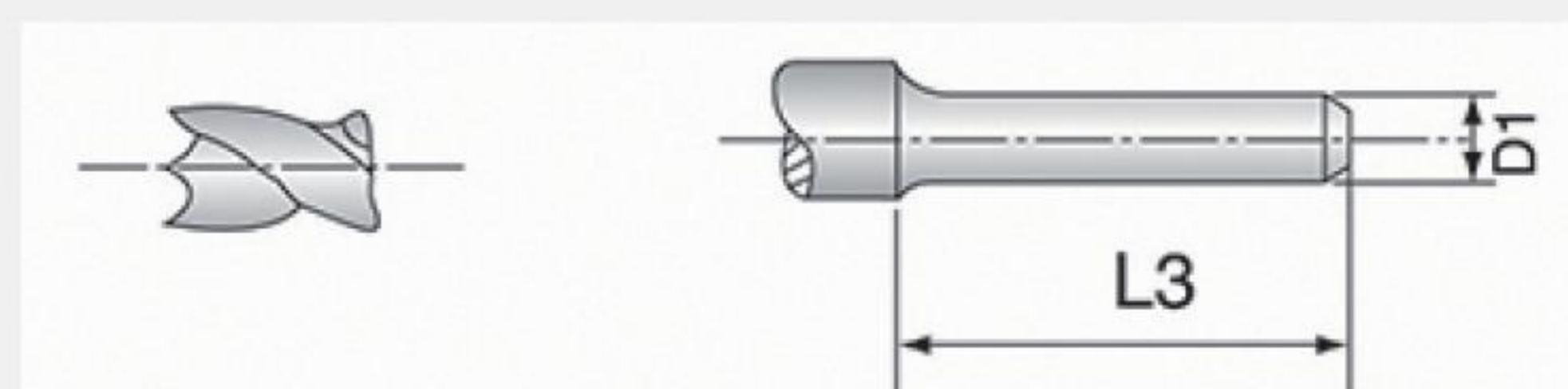
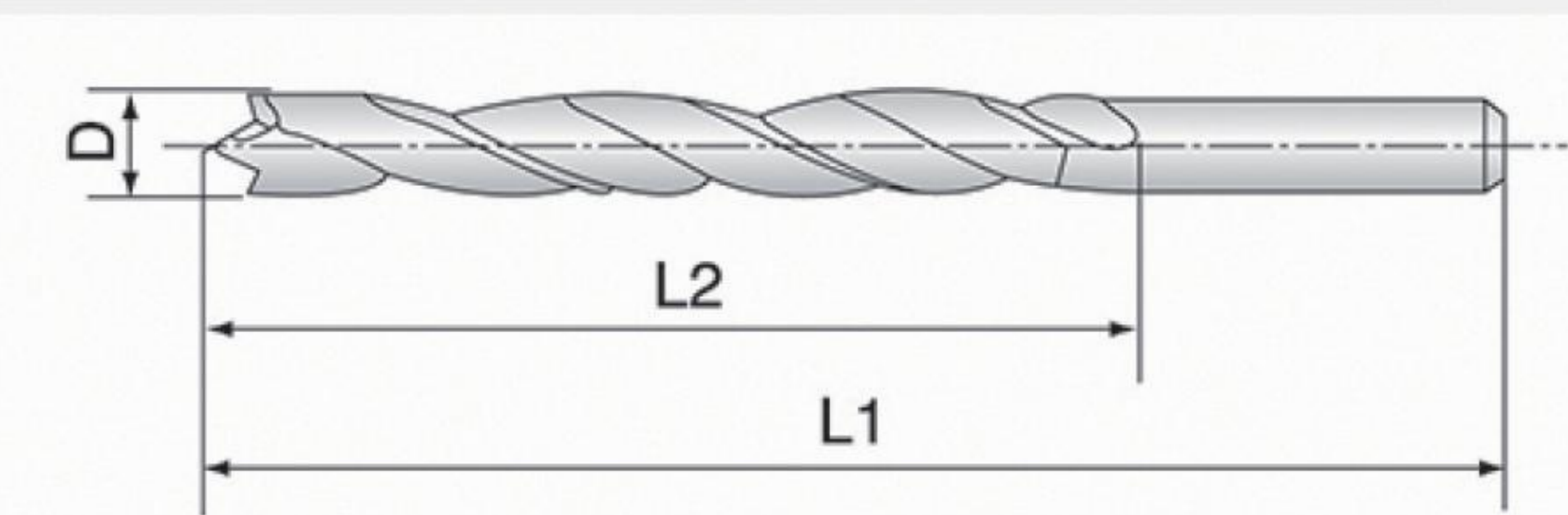

| Dia | L1 | L2 | D1 | L3 | D | L1 | L2 | D1 | L3 |
|------|-----|-----|----|----|------|-----|-----|----|----|
| 3mm | 60 | 32 | | | 3.5 | 70 | 38 | | |
| 4mm | 75 | 43 | | | 4.5 | 80 | 45 | | |
| 5mm | 85 | 51 | | | 5.5 | 92 | 54 | | |
| 6mm | 92 | 54 | | | 6.5 | 100 | 60 | | |
| 7mm | 100 | 60 | | | 7.5 | 105 | 60 | | |
| 8mm | 115 | 71 | | | 8.5 | 115 | 71 | | |
| 9mm | 115 | 71 | | | 9.5 | 115 | 85 | | |
| 10mm | 120 | 82 | | | 10.5 | 130 | 82 | | |
| 11mm | 140 | 90 | | | 11.5 | 140 | 90 | | |
| 12mm | 140 | 90 | | | 12.5 | 150 | 95 | 12 | 20 |
| 13mm | 150 | 95 | 12 | 20 | 13.5 | 150 | 95 | 12 | 20 |
| 14mm | 150 | 95 | 12 | 20 | 14.5 | 160 | 100 | 12 | 20 |
| 15mm | 160 | 100 | 12 | 20 | 15.5 | 160 | 100 | 12 | 20 |
| 16mm | 160 | 100 | 12 | 20 | 16.5 | 170 | 115 | 12 | 20 |
| 18mm | 170 | 115 | 12 | 20 | 18.5 | 170 | 115 | 12 | 20 |
| 20mm | 180 | 130 | 12 | 20 | | | | | |
| 22mm | 200 | 150 | 20 | 30 | | | | | |
| 24mm | 200 | 150 | 20 | 30 | | | | | |
| 26mm | 250 | 170 | 20 | 30 | | | | | |
| 28mm | 250 | 170 | 20 | 30 | | | | | |
| 30mm | 260 | 180 | 20 | 30 | | | | | |
| 32mm | 280 | 195 | 20 | 30 | | | | | |
| 34mm | 285 | 200 | 20 | 30 | | | | | |
| 36mm | 290 | 205 | 20 | 30 | | | | | |
| 38mm | 295 | 210 | 20 | 30 | | | | | |
| 40mm | 300 | 215 | 20 | 30 | | | | | |

BRAD POINT DRILL SET



SPADE BIT/FLAT WOOD DRILL BIT



| Working Diameter | | Shank Diameter | | Overall Length(mm) |
|------------------|---------|----------------|-----------|--------------------|
| Metric (mm) | Inch | Metric (mm) | Inch | |
| 6 | 1/4" | 4.8;6.35 | 3/16;1/4" | 100;152;300;400 |
| 8 | 5/16" | 4.8;6.35 | 3/16;1/4" | 100;152;300;400 |
| 10 | 3/8" | 4.8;6.35 | 3/16;1/4" | 100;152;300;400 |
| 12 | 1/2" | 4.8;6.35 | 3/16;1/4" | 100;152;300;400 |
| 14 | 9/16" | 4.8;6.35 | 3/16;1/4" | 100;152;300;400 |
| 16 | 5/8" | 4.8;6.35 | 3/16;1/4" | 100;152;300;400 |
| 18 | 23/32" | 4.8;6.35 | 3/16;1/4" | 100;152;300;400 |
| 20 | 3/4" | 4.8;6.35 | 3/16;1/4" | 100;152;300;400 |
| 22 | 7/8" | 4.8;6.35 | 3/16;1/4" | 100;152;300;400 |
| 24 | 15/16" | 4.8;6.35 | 3/16;1/4" | 100;152;300;400 |
| 25 | 1" | 4.8;6.35 | 3/16;1/4" | 100;152;300;400 |
| 28 | 15/16" | 4.8;6.35 | 3/16;1/4" | 100;152;300;400 |
| 30 | 1-1/8" | 4.8;6.35 | 3/16;1/4" | 100;152;300;400 |
| 32 | 1-1/4" | 4.8;6.35 | 3/16;1/4" | 100;152;300;400 |
| 34 | 1-5/16" | 4.8;6.35 | 3/16;1/4" | 100;152;300;400 |
| 36 | 1-3/8" | 4.8;6.35 | 3/16;1/4" | 100;152;300;400 |
| 38 | 1-1/2" | 4.8;6.35 | 3/16;1/4" | 100;152;300;400 |
| 40 | 1-9/16" | 4.8;6.35 | 3/16;1/4" | 100;152;300;400 |



TILE & GLASS DRILL BIT

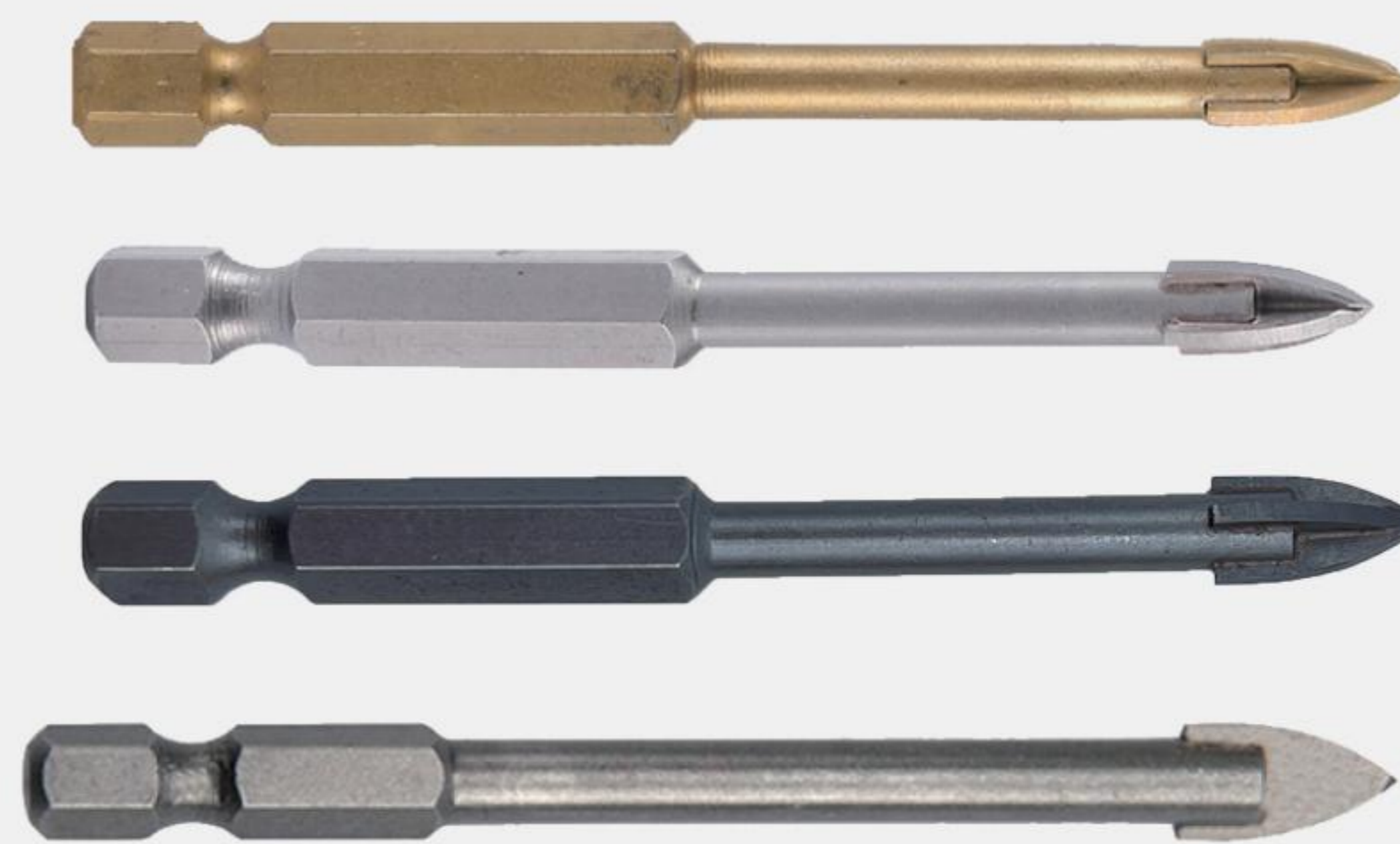

| Item Number | Diameter (mm) | Overall Length (mm) |
|-------------|---------------|---------------------|
|-------------|---------------|---------------------|

| | | |
|------------|----|-----|
| EC06GTD001 | 3 | 60 |
| EC06GTD002 | 4 | 60 |
| EC06GTD003 | 5 | 60 |
| EC06GTD004 | 6 | 60 |
| EC06GTD005 | 8 | 80 |
| EC06GTD006 | 10 | 100 |
| EC06GTD007 | 12 | 100 |
| EC06GTD008 | 14 | 100 |
| EC06GTD009 | 16 | 100 |

| Item Number | Diameter (Inche) | Overall Length (Inche) |
|-------------|------------------|------------------------|
|-------------|------------------|------------------------|

| | | |
|------------|--------|--------|
| EC06GTD010 | 1/8" | 2-1/2" |
| EC06GTD011 | 5/32" | 2-1/2" |
| EC06GTD012 | 3/16" | 2-1/2" |
| EC06GTD013 | 15/64" | 2-1/2" |
| EC06GTD014 | 1/4" | 2-1/2" |
| EC06GTD015 | 5/16" | 3-1/2" |
| EC06GTD016 | 3/8" | 4" |
| EC06GTD017 | 15/32" | 4" |
| EC06GTD018 | 1/2" | 4" |
| EC06GTD019 | 9/16" | 4" |
| EC06GTD020 | 5/8" | 4" |

TILE & GLASS DRILL BIT SET

